

MOTORIZED BRUSH CLEANER

Effective Cleaning Solution for Chevron, Cleated and Raised-rib Belts

Chevron, cleated and raised-rib belts present a special problem for efficient cleaning. The Motorized Brush Cleaner is an ideal option for cleaning these belts. It also performs well as the second or third cleaner in a system with worn or pitted belts, as the bristles effectively dislodge trapped material.

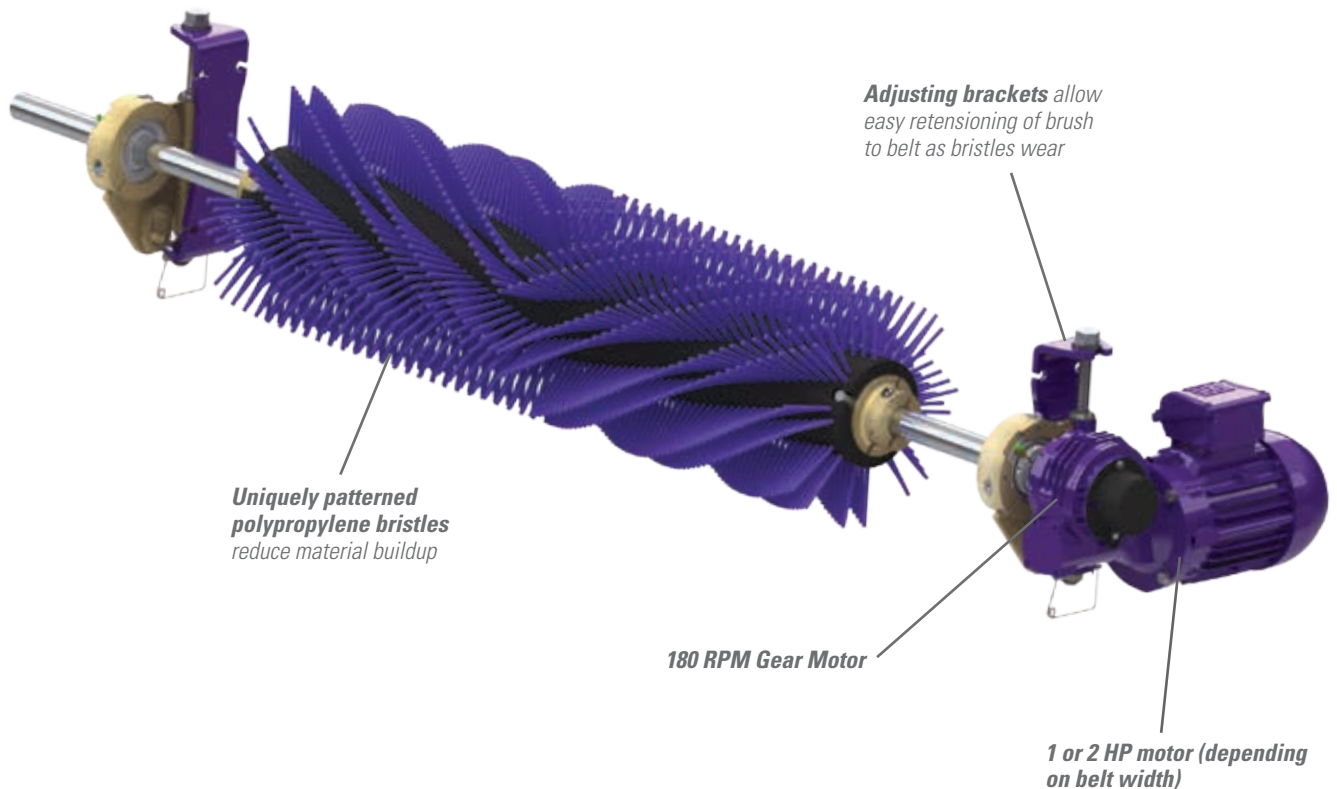

Features and Benefits

- **Maximum Cleaning.** Spins opposite the belt direction for optimal cleaning.
- **Uniquely patterned bristles.** Aids in reducing material buildup and clogging.
- **Adjustable tensioners.** Allows easy brush-to-belt adjustment as the bristles wear.
- **Works on mechanically spliced or vulcanized belts.**

MOTORIZED BRUSH CLEANER

Specifications and Guidelines

- **Maximum Belt Speed**
3.5 M/sec
 - **Temperature Rating**
-30° C to 82° C
 - **Overall Brush Diameter**
305mm
 - **Bristle Material**
Polypropylene
 - **Bristle Length**
83mm
 - **Brush RPM**
180
 - **Shaft Diameter**
38mm
 - **Shaft Length**
Belt Width +1067mm
 - **Maximum Chevron or Cleat Height**
13mm
 - **Motor Voltage and HP**
208-230/460VAC 3 Phase*
1HP (Cleaners 450-1050mm)
2HP (Cleaners 1200-2100mm)
575V 3 Phase*
1HP (Cleaners (450-900mm)
2HP (Cleaners (1050-2100mm)
 - **Available for Belt Widths**
450 to 2100mm
 - **Horizontal Clearance Required**
305mm
 - **Vertical Clearance Required**
305mm
- *other motors available upon request

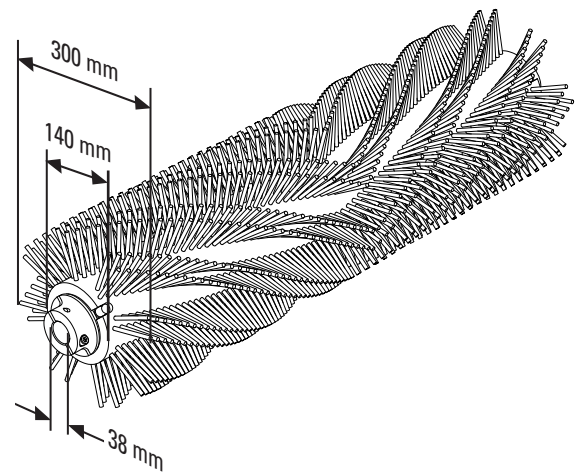
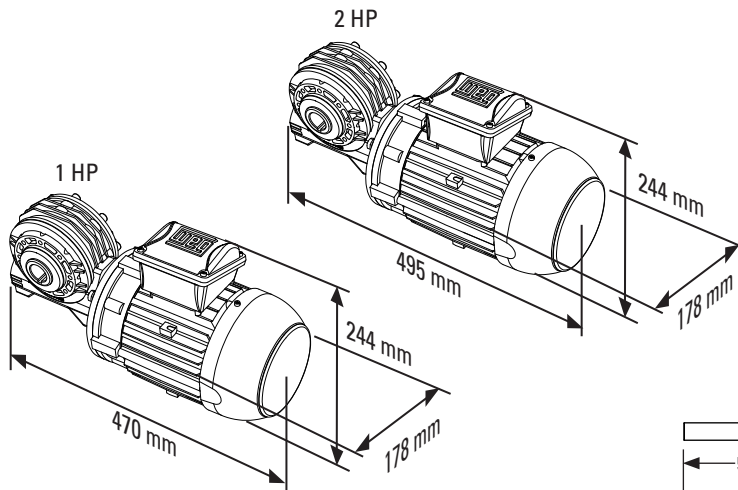

Shaft Measurements
Bearing Stops

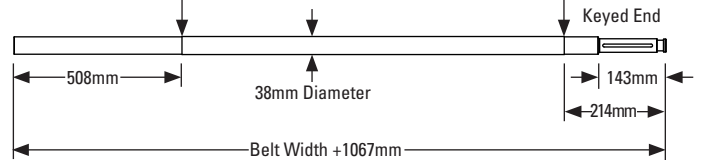

Ordering Information

Motorized Brush Cleaner 208-230/460 VAC 3-Phase Motor					
Belt Width		Brush Coverage		Ordering Number	Item Code
mm	in.	mm	in.		
450	18	450	18	MBC-18	79494
600	24	600	24	MBC-24	79495
750	30	750	30	MBC-30	79496
900	36	900	36	MBC-36	79497
1050	42	1050	42	MBC-42	79498
1200	48	1200	48	MBC-48	79499
1350	54	1350	54	MBC-54	79500
1500	60	1500	60	MBC-60	79501
1800	72	1800	72	MBC-72	79502
2100	84	2100	84	MBC-84	79503

Motorized Brush Cleaner 575V 3-Phase Motor					
Belt Width		Brush Coverage		Ordering Number	Item Code
mm	in.	mm	in.		
450	18	450	18	MBC-18-575V	79914
600	24	600	24	MBC-24-575V	79915
750	30	750	30	MBC-30-575V	79916
900	36	900	36	MBC-36-575V	79917
1050	42	1050	42	MBC-42-575V	79918
1200	48	1200	48	MBC-48-575V	79919
1350	54	1350	54	MBC-54-575V	79920
1500	60	1500	60	MBC-60-575V	79921
1800	72	1800	72	MBC-72-575V	79922
2100	84	2100	84	MBC-84-575V	79923

Replacement Brushes	
Ordering Number	Item Code
MBRD-18	79514
MBRD-24	79515
MBRD-30	79516
MBRD-36	79517
MBRD-42	79518
MBRD-48	79519
MBRD-54	79520
MBRD-60	79521
MBRD-72	79522
MBRD-84	79523

Authorized Distributor:

Flexco Europe GmbH • Leidringer Strasse 40-42 • D-72348 Rosenfeld • Deutschland
Tel: +49-7428-9406-0 • Fax: +49-7428-9406-260 • E-mail: europe@flexco.com

Visit www.flexco.com for other Flexco locations and products.

©2016 Flexible Steel Lacing Company. 06/27/16. For reorder: X3748

