

MOTORIZED BRUSH CLEANER

Effective Cleaning Solution for Chevron, Cleated and Raised-rib Belts

Chevron, cleated and raised-rib belts present a special problem for efficient cleaning. The Motorized Brush Cleaner is an ideal option for cleaning these belts. It also performs well as the second or third cleaner in a system with worn or pitted belts, as the bristles effectively dislodge trapped material.

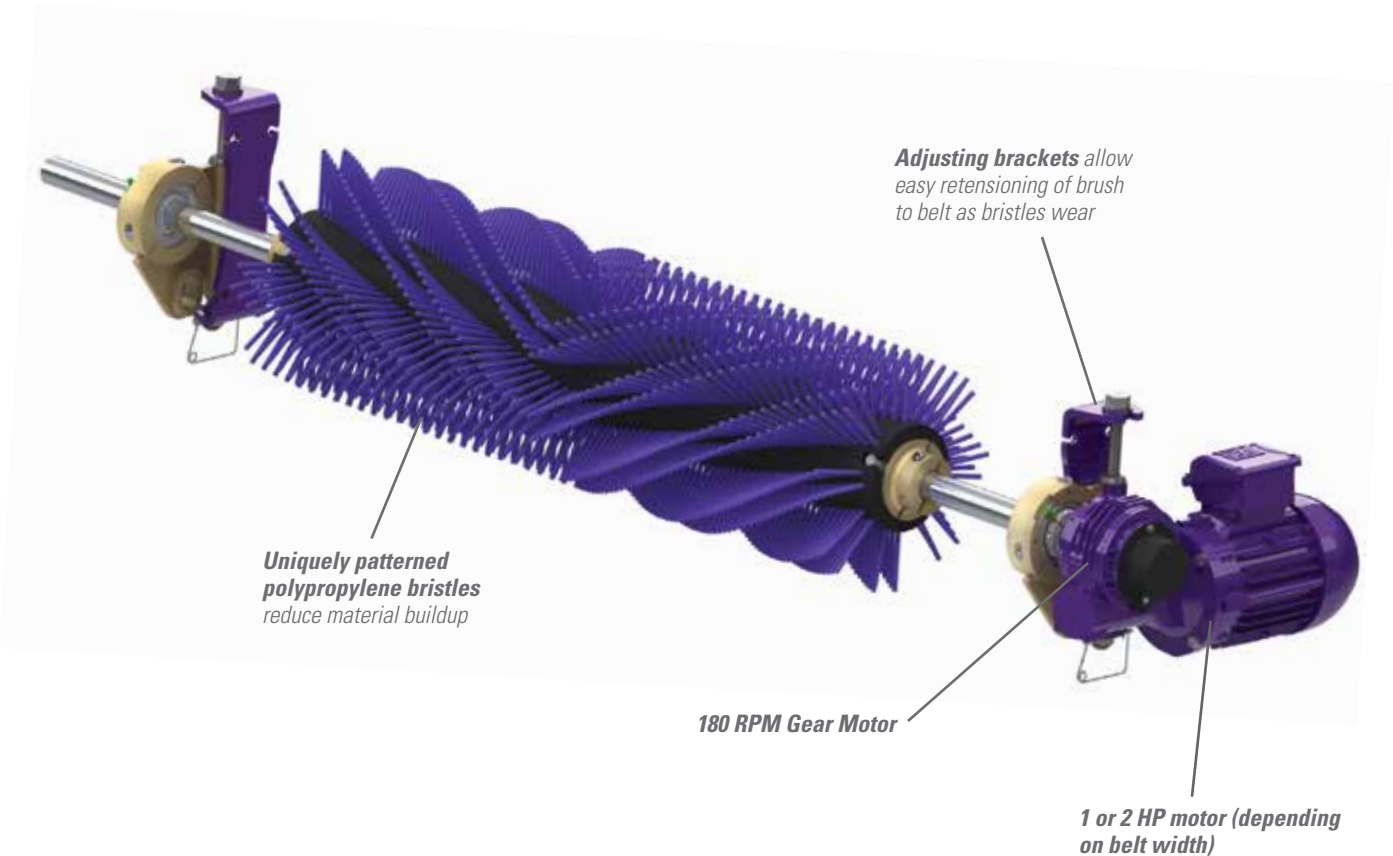

Features and Benefits

- **Maximum Cleaning.** Spins opposite the belt direction for optimal cleaning.
- **Uniquely patterned bristles.** Aids in reducing material buildup and clogging.
- **Adjustable tensioners.** Allows easy brush-to-belt adjustment as the bristles wear.
- **Works on mechanically spliced or vulcanized belts.**

MOTORIZED BRUSH CLEANER

Specifications and Guidelines

- Maximum Belt Speed**
 700 FPM (3.5 M/sec)
- Temperature Rating**
 -20°F to 180° F (-30° C to 82° C)
- CEMA Cleaner Rating**
 Class 4
- Overall Brush Diameter**
 12" (305mm)
- Bristle Material**
 Polypropylene
- Bristle Length**
 3-1/4" (83mm)
- Brush RPM**
 180
- Shaft Diameter**
 1-1/2" (38mm)
- Shaft Length**
 Belt Width + 42" (1067mm)
- Maximum Chevron or Cleat Height**
 1/2" (13mm)
- Motor Voltage and HP**
208-230/460VAC 3 Phase*
 1HP (Cleaners 18-42" (450-1050mm))
 2HP (Cleaners 48-84" (1200-2100mm))
575V 3 Phase*
 1HP (Cleaners 18-36" (450-900mm))
 2HP (Cleaners 42-84" (1050-2100mm))
- Available for Belt Widths**
 18" to 84" (450 to 2100mm)
- Horizontal Clearance Required**
 12" (305mm)
- Vertical Clearance Required**
 12" (305mm)

*other motors available upon request

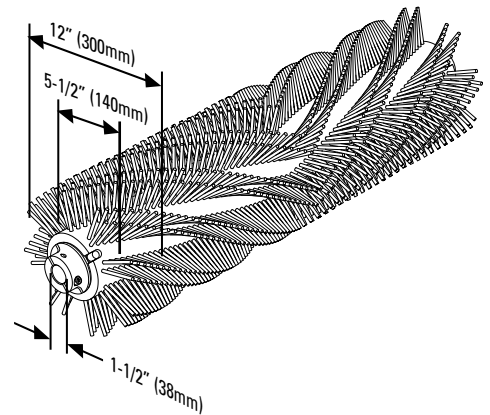
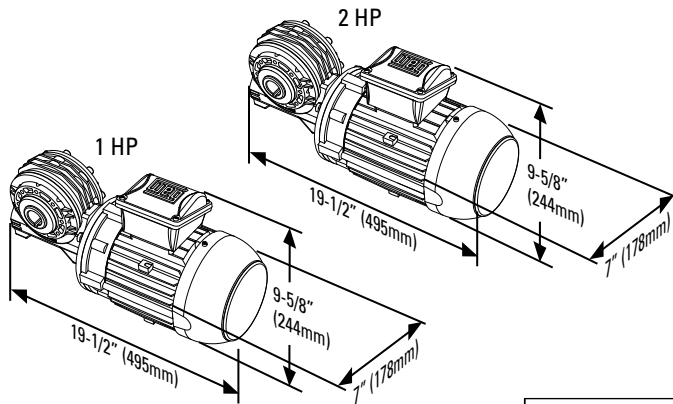

Shaft Measurements

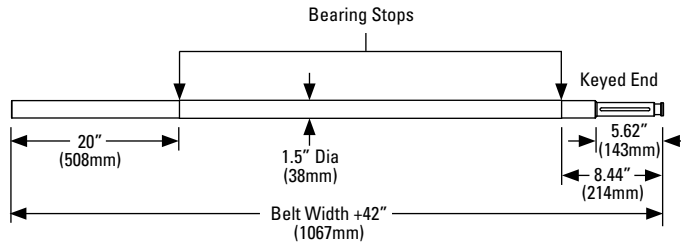

Ordering Information

Motorized Brush Cleaner 208-230/460 VAC 3-Phase Motor					
Belt Width		Brush Coverage		Ordering Number	Item Code
in.	mm	in.	mm		
18	450	18	450	MBC-18	79494
24	600	24	600	MBC-24	79495
30	750	30	750	MBC-30	79496
36	900	36	900	MBC-36	79497
42	1050	42	1050	MBC-42	79498
48	1200	48	1200	MBC-48	79499
54	1350	54	1350	MBC-54	79500
60	1500	60	1500	MBC-60	79501
72	1800	72	1800	MBC-72	79502
84	2100	84	2100	MBC-84	79503

Motorized Brush Cleaner 575V 3-Phase Motor					
Belt Width		Brush Coverage		Ordering Number	Item Code
in.	mm	in.	mm		
18	450	18	450	MBC-18-575V	79914
24	600	24	600	MBC-24-575V	79915
30	750	30	750	MBC-30-575V	79916
36	900	36	900	MBC-36-575V	79917
42	1050	42	1050	MBC-42-575V	79918
48	1200	48	1200	MBC-48-575V	79919
54	1350	54	1350	MBC-54-575V	79920
60	1500	60	1500	MBC-60-575V	79921
72	1800	72	1800	MBC-72-575V	79922
84	2100	84	2100	MBC-84-575V	79923

Replacement Brushes	
Ordering Number	Item Code
MBRD-18	79514
MBRD-24	79515
MBRD-30	79516
MBRD-36	79517
MBRD-42	79518
MBRD-48	79519
MBRD-54	79520
MBRD-60	79521
MBRD-72	79522
MBRD-84	79523

Lead time: 1 working day

Authorized Distributor:



2525 Wisconsin Avenue • Downers Grove, IL 60515-4200 • USA
 Tel: (630) 971-0150 • Fax: (630) 971-1180 • E-mail: info@flexco.com

Visit www.flexco.com for other Flexco locations and products.

©2016 Flexible Steel Lacing Company. 02/16. For reorder: X3594

