

HV2 Precleaner

Installation, Operation and Maintenance Manual



HV2 Precleaner

Serial Number: _____
Purchase Date: _____
Purchased From: _____
Installation Date: _____

Serial number information can be found on the Serial Number Label included in the Information Packet found in the cleaner carton.

This information will be helpful for any future inquiries or questions about belt cleaner replacement parts, specifications or troubleshooting.

Table of Contents

Section 1 – Important Information	4
1.1 General Introduction	4
1.2 User Benefits	4
1.3 Service Option	4
Section 2 – Safety Considerations and Precautions	5
2.1 Stationary Conveyors	5
2.2 Operating Conveyors	5
Section 3 – Pre-Installation Checks and Options.....	6
3.1 Checklist	6
3.2 Cleaner Location Adjustments	7
Section 4 – Installation Instructions.....	8
4.1 Installation Instructions.....	8
4.2 Pole Location Charts	11
Section 5 – Pre-Operation Checklist and Testing.....	13
5.1 Pre-Op Checklist	13
5.2 Test Run the Conveyor	13
Section 6 – Maintenance	14
6.1 New Installation Inspection	14
6.2 Routine Visual Inspection	14
6.3 Routine Physical Inspection.....	14
6.4 Blade Replacement Instructions.....	15
6.5 Maintenance Log	17
6.6 Cleaner Maintenance Checklist.....	18
Section 7 – Troubleshooting	19
Section 8 – Specs and CAD Drawings.....	20
8.1 Specifications and Guidelines	20
8.2 CAD Drawings.....	21
Section 9 – Replacement Parts List	22
Section 10 – Other Flexco Conveyor Products	23

Section 1 – Important Information

1.1 General Introduction

We at Flexco are very pleased that you have selected an HV2 Precleaner for your conveyor system.

This manual will help you to understand the operation of this product and assist you in making it work up to its maximum efficiency over its lifetime of service.

It is essential for safe and efficient operation that the information and guidelines presented be properly understood and implemented. This manual will provide safety precautions, installation instructions, maintenance procedures and troubleshooting tips.

If, however, you have any questions or problems that are not covered, please visit our web site or contact our Customer Service Department:

Customer Service: 1-800-541-8028

Visit www.flexco.com for other Flexco locations and products.

Please read this manual thoroughly and pass it on to any others who will be directly responsible for installation, operation and maintenance of this cleaner. While we have tried to make the installation and service tasks as easy and simple as possible, **it does however require correct installation and regular inspections and adjustments to maintain top working condition.**

1.2 User Benefits

Correct installation and regular maintenance will provide the following benefits for your operation:

- Reduced conveyor downtime
- Reduced man-hour labor
- Lower maintenance budget costs
- Increased service life for the belt cleaner and other conveyor components

1.3 Service Option

The HV2 Precleaner is designed to be easily installed and serviced by your on-site personnel. However, if you would prefer complete turn-key factory service, please contact your local Flexco Field Representative.

Section 2 – Safety Considerations and Precautions

Before installing and operating the HV2 Precleaner, it is important to review and understand the following safety information.

There are set-up, maintenance and operational activities involving both **stationary** and **operating** conveyors. Each case has a safety protocol.

2.1 Stationary Conveyors

The following activities are performed on stationary conveyors:

- Installation
- Blade replacement
- Repairs
- Tension adjustments
- Cleaning

DANGER

It is imperative that OSHA/MSHA Lockout/Tagout (LOTO) regulations, 29 CFR 1910.147, be followed before undertaking the preceding activities. Failure to use LOTO exposes workers to uncontrolled behavior of the belt cleaner caused by movement of the conveyor belt. Severe injury or death can result.

Before working:

- Lockout/Tagout the conveyor power source
- Disengage any takeups
- Clear the conveyor belt or clamp securely in place

WARNING

Use Personal Protective Equipment (PPE):

- Safety eyewear
- Hardhats
- Safety footwear

Close quarters, springs and heavy components create a worksite that compromises a worker's eyes, feet and skull.

PPE must be worn to control the foreseeable hazards associated with conveyor belt cleaners. Serious injuries can be avoided.

2.2 Operating Conveyors

There are two routine tasks that must be performed while the conveyor is running:

- Inspection of the cleaning performance
- Dynamic troubleshooting

DANGER

Every belt cleaner is an in-running nip hazard. Never touch or prod an operating cleaner. Cleaner hazards cause instantaneous amputation and entrapment.

WARNING

Belt cleaners can become projectile hazards. Stay as far from the cleaner as practical and use safety eyewear and headgear. Missiles can inflict serious injury.

WARNING

Never adjust anything on an operating cleaner. Unforeseeable belt projections and tears can catch on cleaners and cause violent movements of the cleaner structure. Flailing hardware can cause serious injury or death.

Section 3 – Pre-installation Checks and Options

3.1 Checklist

- Check that the cleaner size is correct for the beltline width
- Check the belt cleaner carton and make sure all the parts are included
- Review the “Tools Needed” list on the top of the installation instructions
- Check the conveyor site:
 - Will the cleaner be installed on a chute
 - Is the install on an open head pulley requiring mounting structure
 - Are there obstructions that may require cleaner location adjustments

Section 3 - Pre-Installation Checks and Options (cont.)

3.2 Cleaner Location Adjustments

In certain applications it is necessary to modify the location of the pre-cleaner pole due to permanent obstacles that obstruct the desired location. Relocating the pole location can be done easily and does not hinder the performance of the cleaner as long as the "C" dimension is maintained.

NOTE: In the following example we will be lowering the pole location in the "Y" direction, but the same method could also be applied in the "X" direction.

Conveyor situation:

Pulley Diameter: 42"

X = 15-3/8"

Y = 21-1/8"

C = 26-1/8"

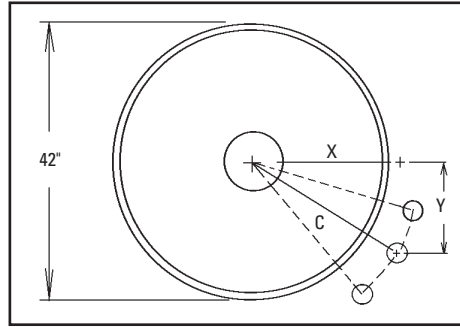

- Determine the given location dimensions and define the change needed.** After laying out the given X & Y dimensions, determine the distance of the modification required for adequate clearance of the pole and tensioning system. (In the example we decide to lower the pole 2" to clear the support structure).
- Write down known dimensions.** We can now determine two of the three required dimensions which will allow us to find the third. We know we cannot alter the "C" dimension, so this will remain the same. Also we are required to lower the unit in the "Y" dimension 2", so we add 2" to the given "Y" dimension.

X = ?"

Y = 21-1/8 + 2 = 23-1/8"

C = 26-1/8"

- Determine final dimension.** On a flat vertical surface, using a level, draw one horizontal line and one vertical line creating a right triangle (Fig 3a). Measure down from the intersection the determined "Y" dimension and mark (Fig 3b). With the tape measure starting at the modified "Y" mark, swing the tape across the "X" line and mark at the "C" dimension where it crosses the "X" line (Fig 3c). Measure from the intersection to the "C" intersection and this will be your new "X" dimension (Fig. 3d).

X = 12-1/8"

Y = 23-1/8"

C = 26-1/8"

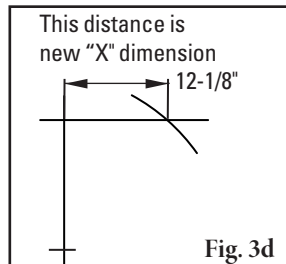
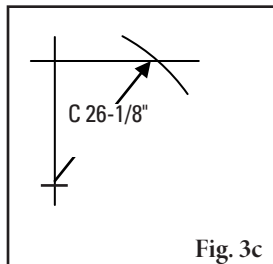
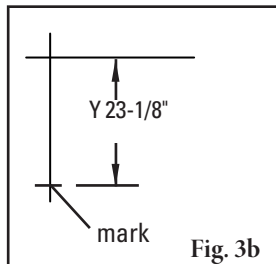
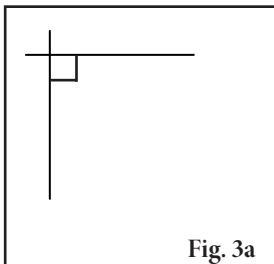

Section 4 – Installation Instructions

4.1 HV2 Precleaner

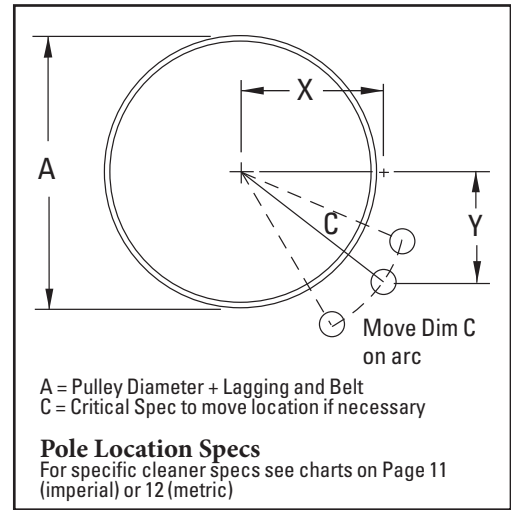
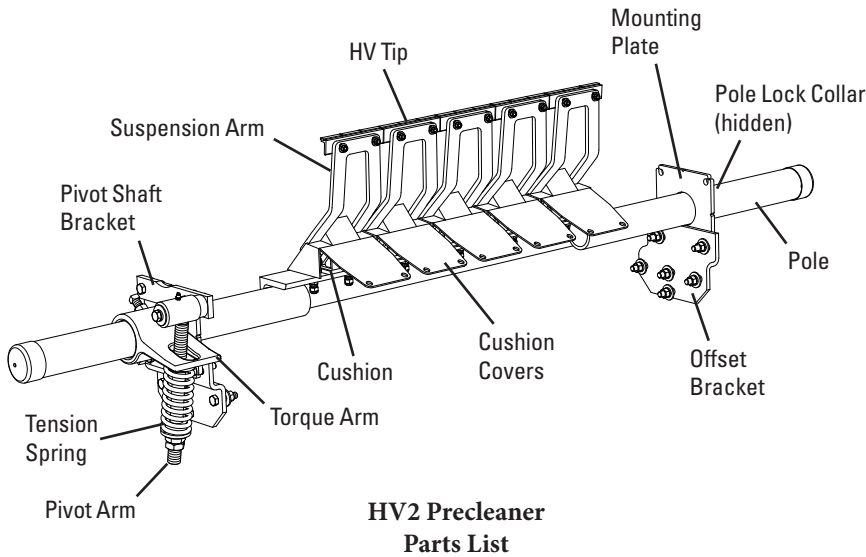

Physically lock out and tag the conveyor at the power source before you begin cleaner installation.

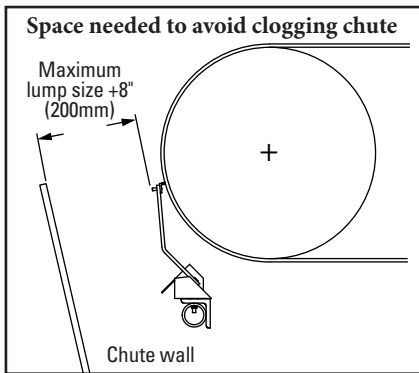

HV Suspension Arm Size	Pulley Diameter + Belt And Lagging
SS	10" - 19" (250-475mm)
S	20" - 31" (500-775mm)
M	32" - 39" (800-975mm)
L	40" - 47" (1000-1175mm)
LL	48" - 67" (1200-1675mm)

- Tools Needed:**
- Tape Measure
 - Level
 - Wrenches or Crescent Wrenches:
 - (1) 1/2" (13mm)
 - (1) 5/8" (16mm)
 - (2) 3/4" (19mm)
 - (1) 15/16" (24mm)
 - (2) 1 1/2" (38mm)

1. **Find X, Y & C measurements.** Find the X and Y measurement specifications for the pulley diameter. See charts on page 11. The pulley diameter measurement should include lagging and belt.
 Pulley Diameter _____"; X= _____"; Y= _____" C= _____"
 Using the correct X and Y coordinates will position the cleaner blades at 15° below the horizontal plane on the head pulley.
2. **Measure head pulley shaft.** Determine the diameter of the pulley shaft and divide by 2. _____"
3. **Locate horizontal line from center of pulley shaft.** Put a level on top of the pulley shaft and draw a horizontal line A. Measure down from Line A half the diameter of the pulley shaft and draw Line B parallel from the pulley shaft (Fig. 1).
4. **Mark X dimension.** Subtract the above dimension (Step 2) from the selected X dimension to establish the modified X dimension. With this new X dimension measure horizontally from the front of the pulley shaft forward on Line B and mark on the chute (Fig. 2).

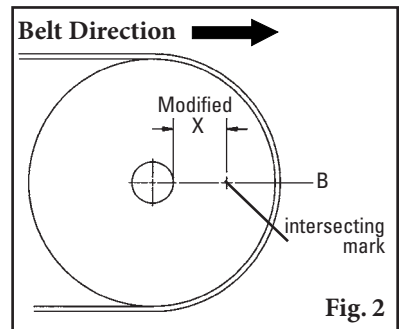
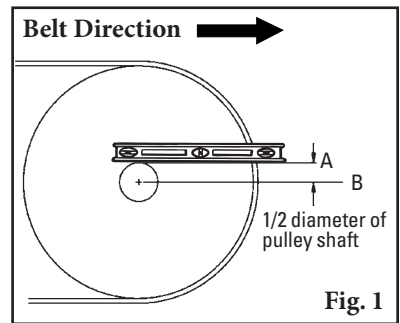

Section 4 – Installation Instructions

4.1 HV2 Precleaner (cont.)

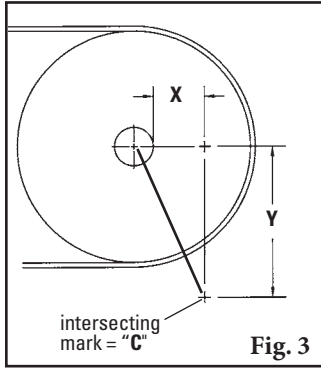

Fig. 3

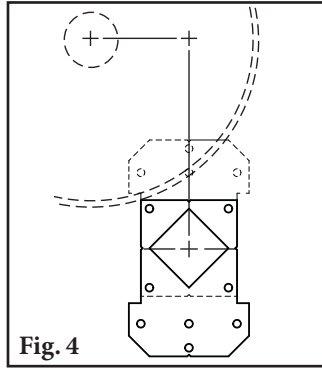

Fig. 4

- Determine Y dimension.** From the X mark, draw a line vertically down to the selected Y dimension and make a mark (Fig. 3). This is the correct position for the center of the pole. Verify “C” dimension from table on page 11 (imperial) or 12 (metric).
- Locate offset bracket position.** To locate the position of the offset bracket, position offset bracket template with the large cutout and notches aligned with the layout lines on the chute wall (Fig. 4). The template can be used with the bracket holes either below or above the Y mark.

- Cut pole opening.** Using template provided, trace and cut the large opening and the mounting holes. If using the offset brackets, the four holes around the diamond cutout do not need to be cut/torched.
- Install offset brackets.** Locate the offset brackets in the correct position on the chute wall and bolt or weld in place (Fig. 5).
- Install the pole.** Slide the pole across the pulley and through the chute openings.
- Install mounting plates.** On one side, slide mounting plate onto pole and bolt to the offset bracket, center in slots and tighten (Fig. 6). Repeat on opposite side.
- Install cushions, then move all cushions to position farthest back from the pulley (Fig. 7).** Snug bolts but do not fully tighten.
- Center the cleaner on the belt and lock in place.** Center the tips on the belt and install a pole lock collar on one end of the pole. Slide the collar snugly up to the mounting plate and tighten.
- Install the QMT spring tensioner.** Remove the adjusting nuts, bushings and spring from the pivot rod. Insert the pivot arm through the slot in the torque arm. Slide the torque arm onto the pole end (be sure the rotation of the arm is correct to tension the blade) and rotate it until the pivot shaft bracket lines up with the desired bolt holes (Fig. 8). Remove bolts, nuts and washers from mounting plate and reinsert through the pivot shaft bracket and mounting plate.

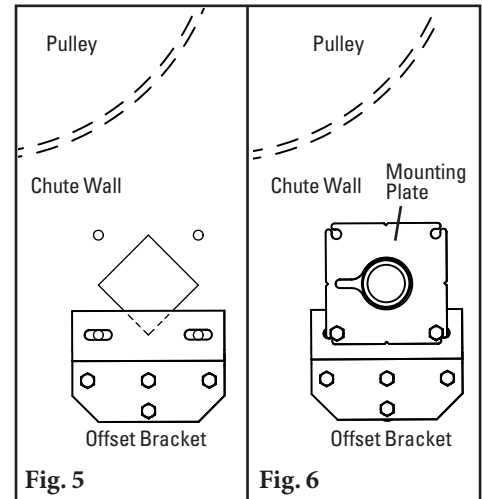

Fig. 5

Fig. 6

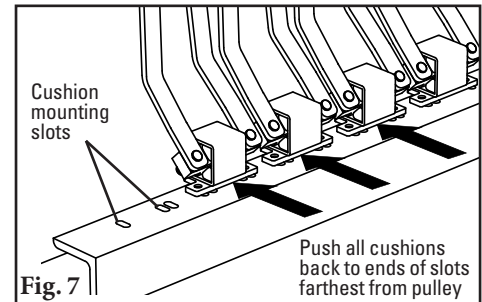

Fig. 7

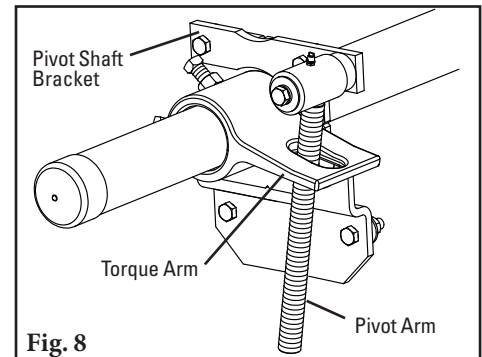
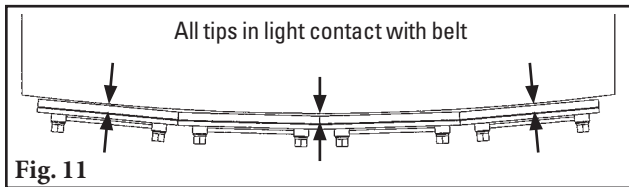
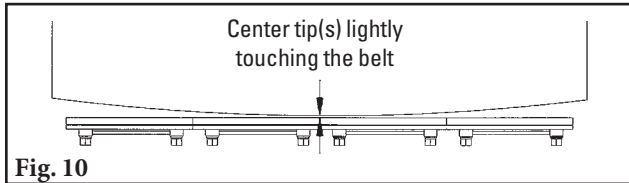

Fig. 8

Section 4 – Installation Instructions

4.1 HV2 Precleaner (cont.)

- 14. Reassemble the spring assembly.** Slide the spring, washer and bushings onto the pivot arm and turn the two adjusting nuts so about 1/4" (6mm) of the pivot arm is exposed above the nuts (Fig. 9).
- 15. Tension the blades to the belt.** Rotate the blades until the center tip(s) just lightly touches the belt (Fig. 10). Adjust the remaining tips, working outward from the center, making sure each tip just lightly touches the belt, and tighten all cushions ensuring the tips remain in light contact with the belt (Fig. 11).



- 16. Ensure the arms/tips can move freely without interfering with each other.** Adjust tips up/down and arms left/right as needed to make sure tips are as close as possible without interfering with each other (Fig. 12). Make sure all tips are aligned and verify the nuts on the arms, cushions and tips are tight.

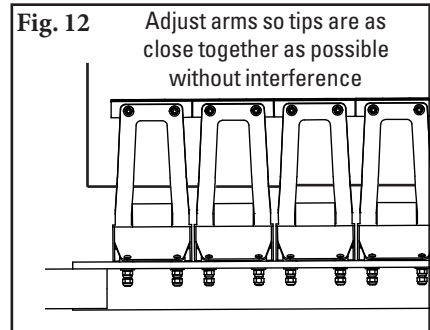
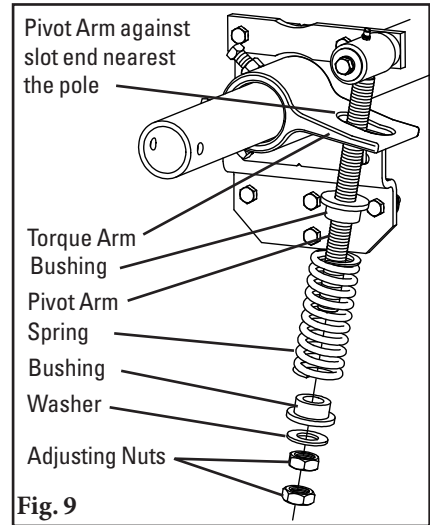

- 17. Set the correct blade tension.** Refer to the chart shown above for the spring length required for the belt width. Lightly pull the pivot arm toward the end of the torque arm slot nearest the pole and turn the adjusting nuts until the required spring length is achieved (Fig. 13). To verify tension, a tip tension scale (sold separately) may be used. Lock the top adjusting nut.

HV2 Spring Length Chart
(for optimal blade tensioning)

Belt Width		Tips	Spring Length									
			SS		S		M		L		LL	
in	mm		in	mm	in	mm	in	mm	in	mm	in	mm
18"	450	2	5 1/4"	133	4 7/8"	124	4 3/4"	121	4 1/2"	114	N/A	N/A
24"	600	3	4 1/2"	114	4 1/8"	105	5 3/4"	146	5 3/4"	146	N/A	N/A
30"	750	4	4 1/2"	114	4 1/8"	105	5 3/4"	146	5 3/4"	146	N/A	N/A
36"	900	5	5 3/4"	146	5 5/8"	143	5 1/2"	140	5 3/8"	137	N/A	N/A
42"	1050	6	5 5/8"	143	5 3/8"	137	5 1/4"	133	5 1/8"	130	4 3/4"	121
48"	1200	7	5 5/8"	143	5 3/8"	137	5 1/4"	133	5 1/8"	130	4 3/4"	121
54"	1350	8	N/A	N/A	5 1/8"	130	5	127	4 7/8"	124	6"	152
60"	1500	9	N/A	N/A	4 7/8"	124	6 1/8"	156	6"	152	5 7/8"	150
72"	1800	11	N/A	N/A	6"	152	6"	152	5 7/8"	150	5 3/4"	146

Purple Spring
 Silver Spring
 White Spring

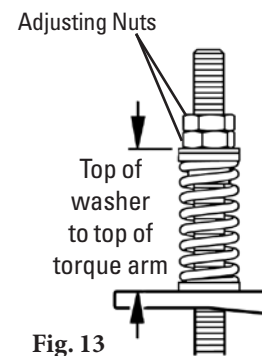

- 18. Verify your "C" dimension** to ensure the pole is in the correct position.
- 19. Wrap cushion cover flaps** under pole, attach to cushion studs, and secure with nuts (Fig. 14).

Test run the cleaner. Run the conveyor for at least 15 minutes and inspect the cleaning performance. Check the spring length for proper tensioning. Make adjustments as necessary. Verify uniform tip tension across the belt. Tip tension scale (sold separately) may be used to verify tension.

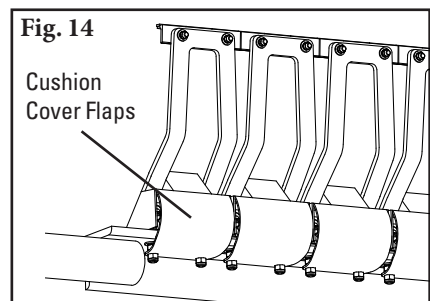

Section 4 – Installation Instructions

4.2 Pole Location Charts (Imperial)

Extra Small (SS) V-Tips for Head Pulley Diameters 10" to 19"			
Diameter (Over Belt)	X	Y	C
10"	1 1/4	12 3/4	12 7/8
11"	1 3/4	12 7/8	13
12"	2 1/4	13 1/8	13 1/4
13"	2 3/4	13 1/4	13 1/2
14"	3 1/8	13 3/8	13 3/4
15"	3 5/8	13 1/2	14
16"	4 1/8	13 5/8	14 1/4
17"	4 5/8	13 3/4	14 1/2
18"	5 1/8	13 7/8	14 3/4
19"	5 5/8	14	15
20"	6 1/8	14 1/8	15 3/8
21"	6 1/2	14 1/4	15 5/8
22"	7	14 3/8	16

Small (S) V-Tips for Head Pulley Diameters 20" to 31"			
Diameter (Over Belt)	X	Y	C
14"	2 3/4	15 3/8	15 5/8
15"	3 1/4	15 5/8	15 7/8
16"	3 3/4	15 3/4	16 1/8
17"	4 1/4	15 7/8	16 3/8
18"	4 3/4	16	16 5/8
19"	5 1/4	16 1/8	16 7/8
20"	5 3/4	16 1/4	17 1/8
21"	6 1/4	16 3/8	17 1/2
22"	6 5/8	16 1/2	17 3/4
23"	7 1/8	16 5/8	18 1/8
24"	7 5/8	16 3/4	18 3/8
25"	8 1/8	16 7/8	18 3/4
26"	8 5/8	17	19
27"	9 1/8	17 1/8	19 3/8
28"	9 5/8	17 1/4	19 3/4
29"	10	17 3/8	20 1/8
30"	10 1/2	17 1/2	20 3/8
31"	11	17 5/8	20 3/4
32"	11 1/2	17 3/4	21 1/8
33"	12	17 7/8	21 1/2
34"	12 1/2	18	21 7/8
35"	13	18 1/8	22 1/4

Medium (M) V-Tips for Head Pulley Diameters 32" to 39"			
Diameter (Over Belt)	X	Y	C
26"	8 1/4	18 1/4	20
27"	8 3/4	18 3/8	20 3/8
28"	9 1/4	18 1/2	20 5/8
29"	9 3/4	18 5/8	21
30"	10 1/4	18 3/4	21 3/8
31"	10 3/4	18 7/8	21 5/8
32"	11 1/4	19	22
33"	11 5/8	19 1/8	22 3/8
34"	12 1/8	19 1/4	22 3/4
35"	12 5/8	19 3/8	23 1/8
36"	13 1/8	19 1/2	23 1/2
37"	13 5/8	19 5/8	23 7/8
38"	14 1/8	19 3/4	24 1/4
39"	14 5/8	19 7/8	24 5/8
40"	15	20	25
41"	15 1/2	20 1/8	25 1/2
42"	16	20 1/4	25 7/8
43"	16 1/2	20 3/8	26 1/4
44"	17	20 1/2	26 5/8
45"	17 1/2	20 5/8	27

Recommended range for tip size
 Optional extended range

Verify "C" Dimension to ensure pole is in the correct position

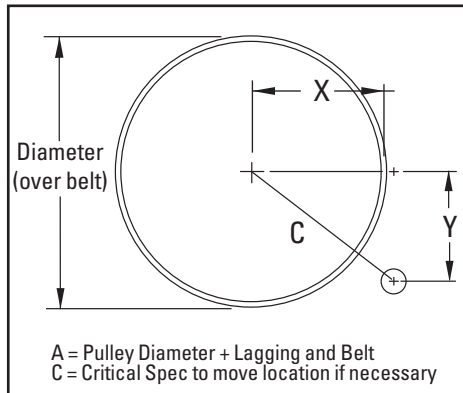

Large (L) V-Tips for Head Pulley Diameters 40" to 47"			
Diameter (Over Belt)	X	Y	C
34"	12	20	23 1/4
35"	12 3/8	20 1/8	23 5/8
36"	12 7/8	20 1/4	24
37"	13 3/8	20 3/8	24 3/8
38"	13 7/8	20 1/2	24 3/4
39"	14 3/8	20 5/8	25 1/8
40"	14 7/8	20 3/4	25 1/2
41"	15 3/8	20 7/8	25 7/8
42"	15 3/4	21	26 1/4
43"	16 1/4	21 1/8	26 5/8
44"	16 3/4	21 1/4	27 1/8
45"	17 1/4	21 3/8	27 1/2
46"	17 3/4	21 1/2	27 7/8
47"	18 1/4	21 5/8	28 1/4
48"	18 3/4	21 3/4	28 3/4
49"	19 1/4	21 7/8	29 1/8
50"	19 5/8	22	29 1/2
51"	20 1/8	22 1/8	30
52"	20 5/8	22 1/4	30 3/8

Extra Large (LL) V-Tips for Head Pulley Diameters 48" to 67"			
Diameter (Over Belt)	X	Y	C
48"	18 3/8	23 1/4	29 5/8
49"	18 7/8	23 3/8	30
50"	19 3/8	23 1/2	30 3/8
51"	19 7/8	23 5/8	30 7/8
52"	20 1/4	23 3/4	31 1/4
53"	20 3/4	23 7/8	31 5/8
54"	21 1/4	24	32 1/8
55"	21 3/4	24 1/8	32 1/2
56"	22 1/4	24 1/4	32 7/8
57"	22 3/4	24 3/8	33 3/8
58"	23 1/4	24 1/2	33 3/4
59"	23 5/8	24 5/8	34 1/8
60"	24 1/8	24 3/4	34 5/8
61"	24 5/8	24 7/8	35
62"	25 1/8	25	35 1/2
63"	25 5/8	25 1/8	35 7/8
64"	26 1/8	25 1/4	36 3/8
65"	26 5/8	25 3/8	36 3/4
66"	27	25 1/2	37 1/4
67"	27 1/2	25 5/8	37 5/8

Section 4 – Installation Instructions

4.3 Pole Location Charts (Metric)

**Extra Small (SS) V-Tips
for Head Pulley Diameters
250 to 475mm**

Diameter (Over Belt)	X	Y	C
250	32	324	328
275	45	328	331
300	58	334	337
325	70	337	343
350	80	340	350
375	93	343	356
400	105	347	362
425	118	350	369
450	131	353	375
475	143	356	381
500	156	359	391
525	166	362	397
550	178	366	407

**Small (S) V-Tips
for Head Pulley Diameters
500 to 775mm**

Diameter (Over Belt)	X	Y	C
350	70	391	397
375	83	397	404
400	96	401	410
425	108	404	416
450	121	407	423
475	134	410	429
500	147	413	435
525	159	416	445
550	169	420	451
575	181	423	461
600	194	426	467
625	207	429	477
650	220	432	483
675	232	435	493
700	245	439	502
725	254	442	512
750	267	445	518
775	280	448	528
800	293	451	537
825	305	455	547
850	318	458	556
875	331	461	566

**Medium (M) V-Tips
for Head Pulley Diameters
800 to 975 mm**

Diameter (Over Belt)	X	Y	C
650	210	464	508
675	223	467	518
700	235	470	524
725	248	474	534
750	261	477	543
775	274	480	550
800	286	483	559
825	296	486	569
850	308	489	578
875	321	493	588
900	334	496	597
925	347	499	607
950	359	502	616
975	372	505	626
1000	381	508	635
1025	394	512	648
1050	407	515	658
1075	420	518	667
1100	432	521	677
1125	445	524	686

□ Recommended range for tip size
 ■ Optional extended range

Verify "C" Dimension to ensure pole is in the correct position

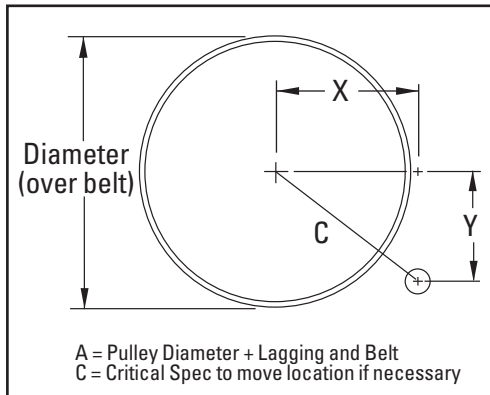

**Large (L) V-Tips
for Head Pulley Diameters
1000 to 1175mm**

Diameter (Over Belt)	X	Y	C
850	305	508	591
875	315	512	601
900	328	515	610
925	340	518	620
950	353	521	629
975	366	524	639
1000	378	528	648
1025	391	531	658
1050	401	534	667
1075	413	537	677
1100	426	540	689
1125	439	543	699
1150	451	547	709
1175	464	550	718
1200	477	553	731
1225	489	556	740
1250	499	559	750
1275	512	562	762
1300	524	566	772

**Extra Large (LL) V-Tips
for Head Pulley Diameters
1200 to 1675mm**

Diameter (Over Belt)	X	Y	C
1200	467	591	753
1225	480	594	762
1250	493	597	772
1275	505	601	785
1300	515	604	794
1325	528	607	804
1350	540	610	816
1375	553	613	826
1400	566	616	836
1425	578	620	848
1450	591	623	858
1475	601	626	867
1500	613	629	880
1525	626	632	889
1550	639	635	902
1575	651	639	912
1600	664	642	924
1625	677	645	934
1650	686	648	947
1675	699	651	956

Section 5 – Pre-Operation Checklist and Testing

5.1 Pre-Op Checklist

- Recheck that all fasteners are tightened properly
- Add pole caps
- Apply all supplied labels to the cleaner
- Check the blade location on the belt
- Be sure that all installation materials and tools have been removed from the belt and the conveyor area

5.2 Test Run the Conveyor

- Run the conveyor for at least 15 minutes and inspect the cleaning performance
- Check the tensioner spring for recommended length (proper tensioning)
- Make adjustments as necessary

NOTE: Observing the cleaner running and performing properly will later aid in detecting when problems are present and/or adjustments are needed.

Section 6 – Maintenance

Flexco belt cleaners are designed to operate with minimum maintenance. However, to maintain superior performance some service is required. When the cleaner is installed a regular maintenance program should be set up. This program will ensure that the cleaner operates at optimal efficiency and problems can be identified and fixed before the cleaner stops working.

All safety procedures for inspection of equipment (stationary or operating) must be observed. The HV2 Precleaner operates at the discharge end of the conveyor and is in direct contact with the moving belt. Only visual observations can be made while the belt is running. Service tasks can be done only with the conveyor stopped and by observing the correct lockout/tagout procedures.

6.1 New Installation Inspection

After the new cleaner has run for a few days a visual inspection should be made to ensure the cleaner is performing properly. Make adjustments as needed.

6.2 Routine Visual Inspection (every 2-4 weeks)

A visual inspection of the cleaner and belt can determine if:

- Spring length is correct for optimal tensioning.
- The belt looks clean or there are areas that are dirty.
- The tips are worn out and need to be replaced.
- There is damage to the tips or other cleaner components.
- Fugitive material is built up on the cleaner or in the transfer area.
- There is cover damage to the belt.
- There is vibration or bouncing of the cleaner on the belt.

If a snub pulley is used, a check should be made for material buildup on the pulley.

If any of the above conditions exist, a determination should be made on when the conveyor can be stopped for cleaner maintenance.

6.3 Routine Physical Inspection (every 6-8 weeks)

When the conveyor is not in operation and properly locked and tagged out, perform a physical inspection of the cleaner to:

- Clean material buildup off of the cleaner tips, arms, cushions and pole.
- Closely inspect the tips for wear and any damage. Replace if needed.
- Ensure full tip to belt contact.
- Inspect the cleaner pole for damage.
- Inspect all fasteners for tightness and wear. Tighten or replace as needed.
- Replace any worn or damaged components.
- Check the tension of the cleaner tips to the belt. Adjust the tension if necessary using the chart on the cleaner or the one on Page 10.
- When maintenance tasks are completed, test run the conveyor to ensure the cleaner is performing properly.

Section 6 – Maintenance

6.4 Blade Replacement Instructions

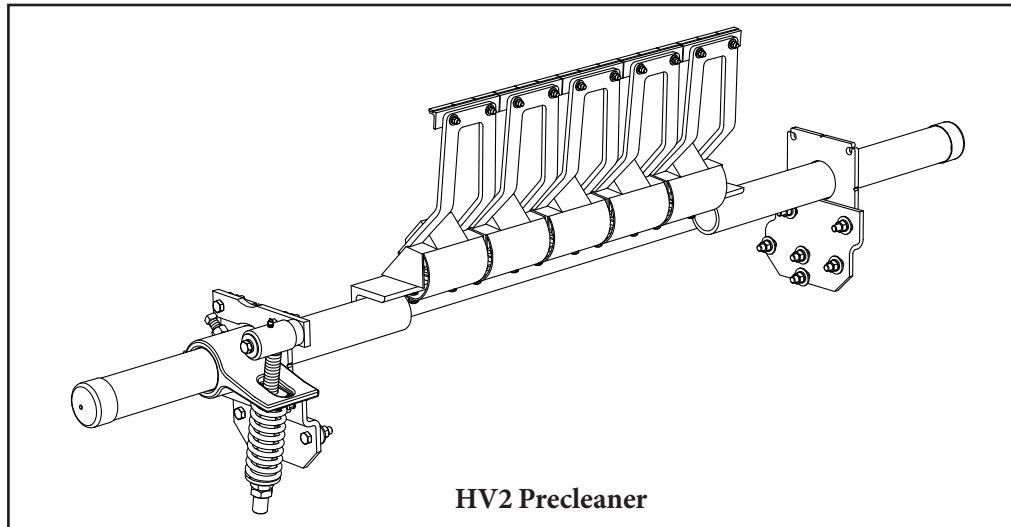

Physically lock out and tag the conveyor at the power source before you begin cleaner installation.

Tools Needed:

- Tape measure
- (1) 1/50mm (2") (13mm) wrench or crescent wrench
- (2) 1½" (38mm) wrenches or crescent wrenches
- Wire brush (for cleaning pole)
- Small putty knife (for cleaning pole)

1. **Remove tension.** Loosen adjusting nuts on both sides and turn them out until they are flush with the ends of the pivot arms (Fig. 1). This releases the tension of the blade on the belt.

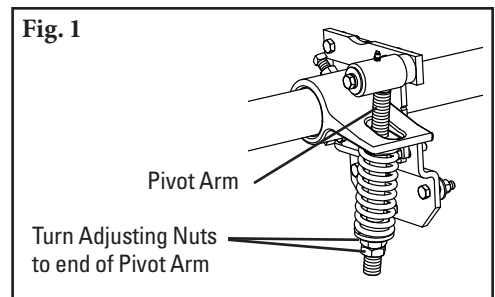

2. **Remove worn tips.** Remove nuts on each tip and remove tips from suspension arm (Fig. 2). Clean all fugitive material from the pole.

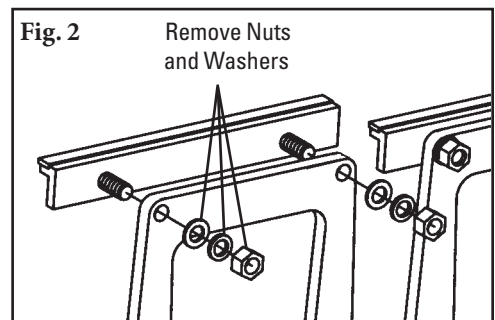

NOTE: If tips are hard to remove use a screwdriver or hammer to loosen and then remove.

Section 6 – Maintenance

6.4 Blade Replacement Instructions (cont.)

3. **Install new tips.** Locate a new tip onto each suspension arm, then install hardware to fasten tip to the cushion (Fig. 3).

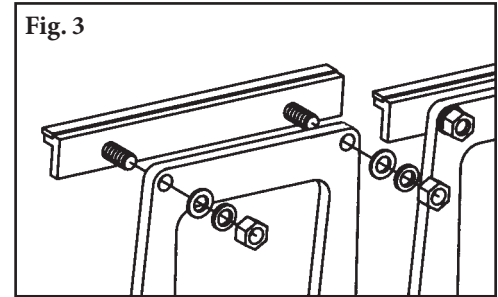

4. **Reset correct blade tension.** Refer to the chart for the spring length required for the belt width. Lightly pull pivot arm toward end of torque arm slot nearest the pole and turn adjusting nuts until required spring length is achieved (Fig. 4). Tighten jam nut.

NOTE: For future reference and/or maintenance, the chart is also on the cleaner’s pivot shaft.

NOTE: Check tip alignment to belt. If adjustments are needed, see steps 15-17 on Page 10.

HV2 Spring Length Chart
(for optimal blade tensioning)

Belt Width		Tips	Spring Length									
in	mm		SS		S		M		L		LL	
			in	mm	in	mm	in	mm	in	mm	in	mm
18"	450	2	5 1/4"	133	4 7/8"	124	4 3/4"	121	4 1/2"	114	N/A	N/A
24"	600	3	4 1/2"	114	4 1/8"	105	5 3/4"	146	5 3/4"	146	N/A	N/A
30"	750	4	4 1/2"	114	4 1/8"	105	5 3/4"	146	5 3/4"	146	N/A	N/A
36"	900	5	5 3/4"	146	5 5/8"	143	5 1/2"	140	5 3/8"	137	N/A	N/A
42"	1050	6	5 5/8"	143	5 3/8"	137	5 1/4"	133	5 1/8"	130	4 3/4"	121
48"	1200	7	5 5/8"	143	5 3/8"	137	5 1/4"	133	5 1/8"	130	4 3/4"	121
54"	1350	8	N/A	N/A	5 1/8"	130	5	127	4 7/8"	124	6"	152
60"	1500	9	N/A	N/A	4 7/8"	124	6 1/8"	156	6"	152	5 7/8"	150
72"	1800	11	N/A	N/A	6"	152	6"	152	5 7/8"	150	5 3/4"	146

Purple Spring
 Silver Spring
 White Spring

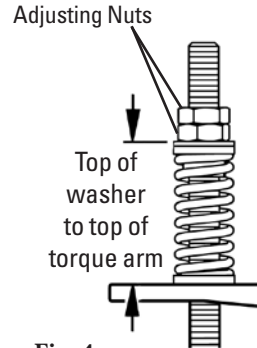

Fig. 4

Test run the cleaner. Run conveyor for at least 15 minutes and inspect the cleaning performance. Check spring length for proper tensioning. Make adjustments as necessary.

Section 6 – Maintenance

6.5 Maintenance Log

Conveyor Name/No. _____

Date: _____ Work done by: _____ Service Quote # _____

Activity: _____

Date: _____ Work done by: _____ Service Quote # _____

Activity: _____

Date: _____ Work done by: _____ Service Quote # _____

Activity: _____

Date: _____ Work done by: _____ Service Quote # _____

Activity: _____

Date: _____ Work done by: _____ Service Quote # _____

Activity: _____

Date: _____ Work done by: _____ Service Quote # _____

Activity: _____

Date: _____ Work done by: _____ Service Quote # _____

Activity: _____



Section 6 – Maintenance

6.6 Cleaner Maintenance Checklist

Belt Cleaner: _____ Serial Number: _____

Beltline Information:

Beltline Number: _____ Belt Condition: _____

Belt Width: 18" 450mm 24" 600mm 30" 750mm 36" 900mm 42" 1050mm 48" 1200mm 54" 1350mm 60" 1500mm 72" 1800mm

Head Pulley Diameter (Belt & Lagging): _____ Belt Speed: _____ fpm Belt Thickness: _____

Belt Splice _____ Condition of Splice _____ Number of splices _____ Skived Unskived

Material conveyed _____

Days per week run _____ Hours per day run _____

Blade Life:

Date blade installed: _____ Date blade inspected: _____ Estimated blade life: _____

Is blade making complete contact with belt? Yes No

Blade wear: LEFT _____ MIDDLE _____ RIGHT _____

Blade condition: Good Grooved Smiled Not contacting belt Damaged

Measurement of spring: Required _____ Currently _____

Was Cleaner Adjusted: Yes No

Pole Condition: Good Bent Worn

Lagging: Slide lag Ceramic Rubber Other None

Condition of lagging: Good Bad Other _____

Cleaner's Overall Performance: (Rate the following 1 - 5, 1 = very poor - 5 = very good)

Appearance: Comments: _____

Location: Comments: _____

Maintenance: Comments: _____

Performance: Comments: _____

Other Comments: _____

Section 7 – Troubleshooting

Problem	Possible Cause	Possible Solutions
Poor cleaning performance	Cleaner under-tensioned	Adjust to correct tension – see spring length chart
	Cleaner over-tensioned	Adjust to correct tension – see spring length chart
	Cleaner installed in wrong location	Verify "C" dimension, relocate to correct dimension
	Cleaner blade worn or damaged	Replace cleaner blade
Rapid Tip Wear	Tension on cleaner too high/low	Adjust to correct tension – see spring length chart
	Cleaner not located correctly	Check cleaner location for correct dimensions
	Blade attack angle incorrect	Check cleaner location for correct dimensions
Unusual wear or damage to tips	Belt damaged or ripped	Repair or replace belt
	Cleaner not correctly located	Verify "C" dimension, relocate to correct dimension
	Damage to pulley or pulley lagging	Repair or replace pulley
Vibration or noise	Cleaner not located correctly	Verify "C" dimension, relocate to correct dimension
	Blade attack angle incorrect	Verify "C" dimension, relocate to correct dimension
	Cleaner running on empty belt	Use a spray pole when the belt is empty
	Cleaner tension too high/low	Adjust to correct tension or slight adjust to diminish
	Cleaner locking bolts not secure	Check and tighten all bolts and nuts
	Cleaner not square to head pulley	Verify "C" dimension, relocate to correct dimension
	Material buildup in chute	Clean build-up on cleaner and in chute
Cleaner being pushed away from pulley	Cleaner tension not set correctly	Ensure correct tension/increase tension slightly
	Sticky material is overburdening cleaner	Increase tension; replace with cleaner with metal tips; replace with larger size cleaner
	Cleaner not set up correctly	Confirm location dimensions are equal on both sides

Section 8 – Specs and CAD Drawings

8.1 Specifications and Guidelines

Pole Length Specifications*

Cleaner Size		Pole Length		Maximum Conveyor Span	
in.	mm	in.	mm	in.	mm
18	450	66	1650	56	1400
24	600	72	1800	62	1550
30	750	78	1950	68	1700
36	900	84	2100	74	1850
42	1050	90	2250	80	2000
48	1200	96	2400	86	2150
54	1350	102	2550	92	2300
60	1500	108	2700	98	2450
72	1800	120	3000	110	2750

*For special extra long pole length requirements a Pole Extender Kit (#76024) is available that provides 30" (750mm) of extended pole length. Pole Diameter - 2-7/8" (73mm)

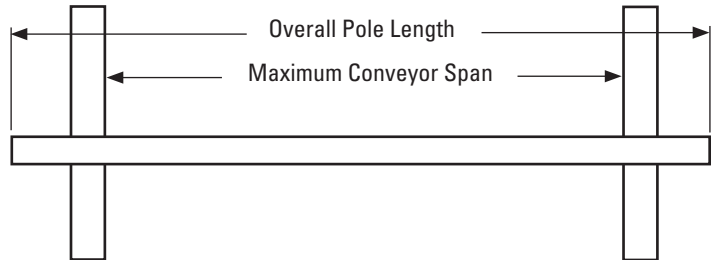

Clearance Guidelines for Installation

Suspension Arm Size	Horizontal Clearance Required		Vertical Clearance Required	
	in.	mm	in.	mm
SS	8-1/4	210	12-5/8	320
S	8-1/4	210	15-3/8	390
M	8-1/4	210	16-5/8	416
L	8-1/4	210	17-1/2	445
LL	8-1/4	210	20-1/8	511

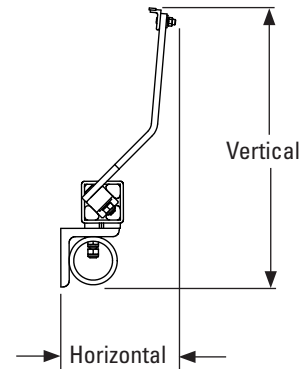

HV2 Spring Length Chart

(for optimal blade tensioning)

Belt Width		Tips	Spring Length									
			SS		S		M		L		LL	
in	mm		in	mm	in	mm	in	mm	in	mm	in	mm
18"	450	2	5 1/4"	133	4 7/8"	124	4 3/4"	121	4 1/2"	114	N/A	N/A
24"	600	3	4 1/2"	114	4 1/8"	105	5 3/4"	146	5 3/4"	146	N/A	N/A
30"	750	4	4 1/2"	114	4 1/8"	105	5 3/4"	146	5 3/4"	146	N/A	N/A
36"	900	5	5 3/4"	146	5 5/8"	143	5 1/2"	140	5 3/8"	137	N/A	N/A
42"	1050	6	5 5/8"	143	5 3/8"	137	5 1/4"	133	5 1/8"	130	4 3/4"	121
48"	1200	7	5 5/8"	143	5 3/8"	137	5 1/4"	133	5 1/8"	130	4 3/4"	121
54"	1350	8	N/A	N/A	5 1/8"	130	5	127	4 7/8"	124	6"	152
60"	1500	9	N/A	N/A	4 7/8"	124	6 1/8"	156	6"	152	5 7/8"	150
72"	1800	11	N/A	N/A	6"	152	6"	152	5 7/8"	150	5 3/4"	146

Purple Spring
 Silver Spring
 White Spring

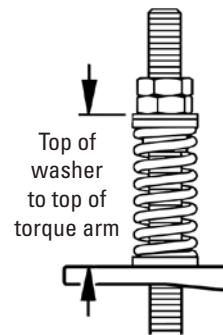

Specifications:

- Maximum Belt Speed.....1500 FPM (7.5M/sec)
- Temperature Rating.....-30°F to 180°F (-35°C to 82°C)
- Usable Blade Wear Length.....3/8" (9mm)
- Blade Material.....Long Life Tungsten Carbide
(for vulcanized belts only)
- Available for Belt Widths.....18" to 750mm (2") (450mm to 1800mm)
Other sizes available upon request.

Section 8 – Specs and CAD Drawings

8.2 CAD Drawing - HV2 Precleaner

TABLE			
FINISHED PART NO.	MODEL	DIM A	DIM B
79323	HV2-18SS	66 9/16	17 9/16
79324	HV2-18S	66 9/16	17 9/16
79325	HV2-18M	66 9/16	17 9/16
79326	HV2-24SS	72 1/2	23 1/2
79327	HV2-24S	72 1/2	23 1/2
79328	HV2-24M	72 1/2	23 1/2
79329	HV2-30SS	78 7/16	29 7/16
79330	HV2-30S	78 7/16	29 7/16
79331	HV2-30M	78 7/16	29 7/16
79332	HV2-36SS	84 3/8	35 3/8
79333	HV2-36S	84 3/8	35 3/8
79334	HV2-36M	84 3/8	35 3/8
79335	HV2-36L	84 3/8	35 3/8
79336	HV2-42SS	90 3/8	41 3/8
79337	HV2-42S	90 3/8	41 3/8
79338	HV2-42M	90 3/8	41 3/8
79339	HV2-42L	90 3/8	41 3/8
79340	HV2-42LL	90 3/8	41 3/8
79341	HV2-48SS	96 5/16	47 5/16
79342	HV2-48S	96 5/16	47 5/16
79343	HV2-48M	96 5/16	47 5/16
79344	HV2-48L	96 5/16	47 5/16
79345	HV2-48LL	96 5/16	47 5/16
79346	HV2-54S	102 1/4	53 1/4
79347	HV2-54M	102 1/4	53 1/4
79348	HV2-54L	102 1/4	53 1/4
79349	HV2-54LL	102 1/4	53 1/4
79350	HV2-60S	108 3/16	59 3/16
79351	HV2-60M	108 3/16	59 3/16
79352	HV2-60L	108 3/16	59 3/16
79353	HV2-60LL	108 3/16	59 3/16
79354	HV2-72S	120 1/16	71 1/16
79355	HV2-72M	120 1/16	71 1/16
79356	HV2-72L	120 1/16	71 1/16
79357	HV2-72LL	120 1/16	71 1/16

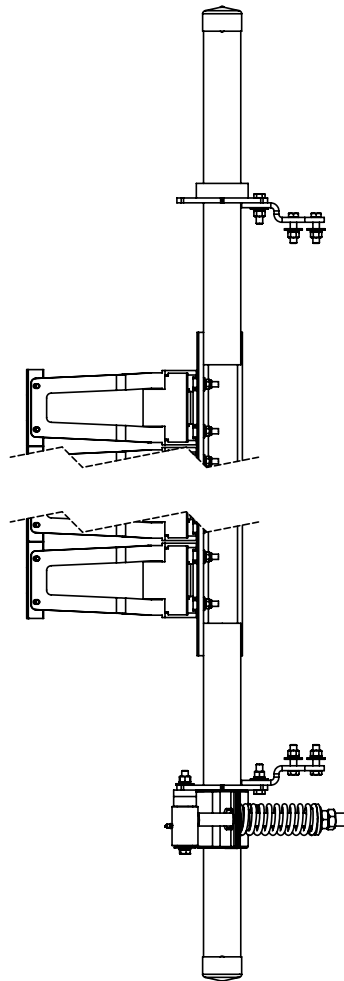
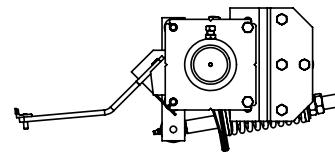
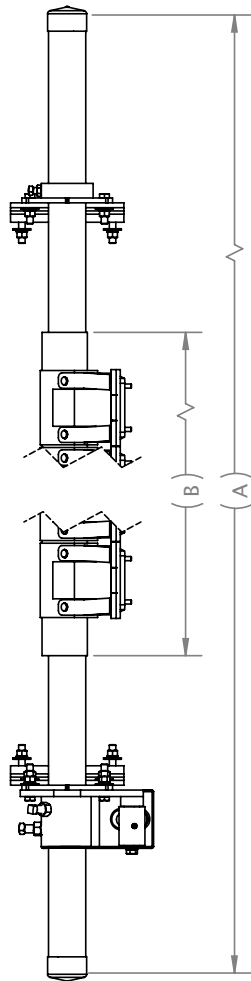

Section 9 – Replacement Parts List

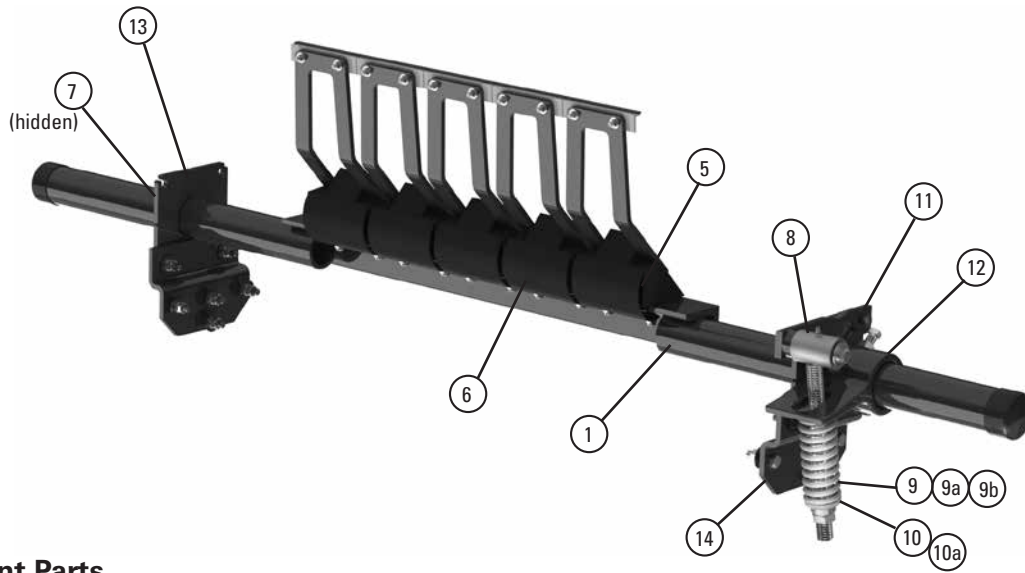

Replacement Parts

Ref	Description	Ordering Number	Item Code	Wt. Lbs.
1	18" (450mm) Pole	H2P18	79358	49.8
	24" (600mm) Pole	H2P24	79359	55.0
	30" (750mm) Pole	H2P30	79360	60.1
	36" (900mm) Pole	H2P36	79361	65.3
	42" (1050mm) Pole	H2P42	79362	70.5
	48" (1200mm) Pole	H2P48	79363	75.6
	54" (1350mm) Pole	H2P54	79364	80.8
	60" (1500mm) Pole	H2P60	79365	86.0
	72" (1800mm) Pole	H2P72	79366	96.3
2	HV2 Tip (6"/150mm Tip, 1 ea.)	HV2T-S/S	79367	0.6
2a	HV2 Protected V-Tip* (6"/150mm Tip, 1 ea.) for vulcanized belts only (for abusive wear)	HV2PT	79368	0.8
3	HV2-S/S Tip Shield (optional)	HV2SSTS	79375	0.5
4	HV2 SS Suspension Arm*	H2SA6SS	79369	2.5
	HV2 S Suspension Arm*	H2SA6S	79370	3.2
	HV2 M Suspension Arm*	H2SA6M	79371	3.6
	HV2 L Suspension Arm*	H2SA6L	79372	3.8
	HV2 LL Suspension Arm*	H2SA6LL	79373	4.5
5	HV2 Cushion	H2RC	79374	4.3
6	HV2 Urethane Cushion Cover	UHVC	79453	0.5
7	Pole Lock Collar* (1 ea.)	MSPPL	75816	1.9
8	Pivot Arm Kit* (1 ea.)	QMTPAK	76096	4.3
9a	Tension Spring - Purple (1 ea.)**	QMTS-P	75845	0.6
9b	Tension Spring - White (1 ea.)**	PSTS-W	75898	1.7
9c	Tension Spring - Silver (1 ea.)**	PSTS-S	75899	3.0
10a	Bushing Kit - Purple (2 ea.) (for Item 9a)	QMTBK-P	76097	0.1
10b	Bushing Kit - White (2 ea.) (for Items 9b & 9c)	QMTBK-W	76098	0.2
11	Pivot Shaft Bracket Kit* (1 ea.)	QMTPSBK	76099	4.3
12	Torque Arm Kit* (1 ea.)	PSTA	75896	11.4
13	Mounting Plate Kit* (2 ea.)	MSPMPK	75811	8.3
14	Offset Bracket Kit* (1 ea.)	HOBK	76399	12.4
-	QMT Spring Tensioner* - Purple (incl. 1 ea. Items 9a, 10a, 11, 12, 13)	QMT-P	76074	20.4
-	QMT Spring Tensioner* - White (incl. 1 ea. Items 9b, 10b, 11, 12, 13)	QMT-W	76075	21.8
-	QMT Spring Tensioner* - Silver (incl. 1 ea. Items 9c, 10b, 11, 12, 13)	VQMT-S	76402	23.9

*Hardware included

Note: All poles and tensioners are heavy-duty style.

Lead time: 1 working day

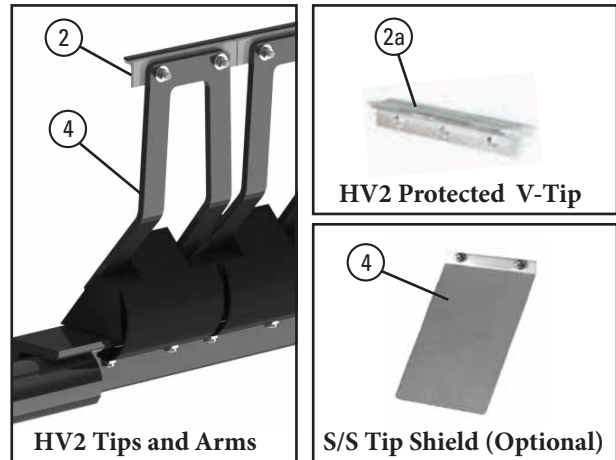

Spring Tensioner Selection Chart

HV2 Pre-cleaner Size	76074 QMT-P	76075 QMT-W	76402 QMT-S
18" SS,S,M; 24" S,S; 30" SS,S	X		
24" M; 30" M; 36" SS-L; 450mm (2") SS-L; 48" SS-LL; 54" S-L; 60" S; 750mm (2") S		X	
54" LL; 60" M-LL; 750mm (2") M-LL			X

Tips Required per Cleaner Size

in.	18	24	30	36	42	48	54	60	72
mm	450	600	750	900	1050	1200	1350	1500	1800
HV2-Tips Required	2	3	4	5	6	7	8	9	11

Section 10 – Other Flexco Conveyor Products

Flexco provides many conveyor products that help your conveyors to run more efficiently and safely. These components solve typical conveyor problems and improve productivity. Here is a quick overview on just a few of them:

EZP1 Precleaner



- Patented ConShear™ blade renews its cleaning edge as it wears
- Visual Tension Check™ for optimal blade tensioning and simple retensioning
- Quick and easy one-pin blade replacement Material Path Option™ for optimal cleaning and reduced maintenance

DRX Impact Beds



- Exclusive Velocity Reduction Technology™ to better protect the belt
- Slide-Out Service™ gives direct access to all impact bars for change-out
- Impact bar supports for longer bar life
- 4 models to custom fit to the application

EZS2 Secondary Cleaner



- Long-wearing tungsten carbide blades for superior cleaning efficiency
- Patented FormFlex™ cushions independently tension each blade to the belt for consistent, constant cleaning power
- Easy to install, simple to service
- Works with Flexco mechanical belt splices

PT Max™ Belt Trainer



- Patented “pivot & tilt” design for superior training action
- Dual sensor rollers on each side to minimize belt damage
- Pivot point guaranteed not to freeze or seize up
- Available for topside and return side belts

Flexco Specialty Belt Cleaners



- “Limited space” cleaners for tight conveyor applications
- High Temp cleaners for severe, high heat applications
- A rubber fingered cleaner for chevron and raised rib belts
- Multiple cleaner styles in stainless steel for corrosive applications

Belt Plows



- A belt cleaner for the tail pulley
- Exclusive blade design quickly spirals debris off the belt
- Economical and easy to service
- Available in vee or diagonal models

The Flexco Vision

To become the leader in maximising
belt conveyor productivity for our customers worldwide
through superior service and innovation.



2525 Wisconsin Avenue • Downers Grove, IL 60515-4200 • USA
Tel: (630) 971-0150 • Fax: (630) 971-1180 • E-mail: info@flexco.com

Visit www.flexco.com for other Flexco locations and products.

©2017 Flexible Steel Lacing Company. 11/21/17. For reorder: X3490

