

# EZP-LS Primary Cleaner

---

## Installation, Operation & Maintenance Manual

---



# EZP-LS Primary Cleaner

---

Purchase Date: \_\_\_\_\_

Purchased From: \_\_\_\_\_

Installation Date: \_\_\_\_\_

This information will be helpful for any future inquiries or questions about belt cleaner replacement parts, specifications or troubleshooting.

# Table of Contents

---

<b>Section 1 - Important Information</b> .....	4
1.1 General Introduction .....	4
1.2 User Benefits .....	4
1.3 Service Option .....	4
<b>Section 2 - Safety Considerations and Precautions</b> .....	5
2.1 Stationary Conveyors .....	5
2.2 Operating Conveyors .....	5
<b>Section 3 - Pre-Installation Checks and Options</b> .....	6
3.1 Checklist .....	6
3.2 Cleaner Location Adjustments .....	7
3.3 Correct Blade Installation and Tensioning .....	8
<b>Section 4 - Installation Instructions</b> .....	9
<b>Section 5 - Pre-Operation Checklist and Testing</b> .....	12
5.1 Pre-Op Checklist .....	12
5.2 Test Run the Conveyor .....	12
<b>Section 6 - Maintenance</b> .....	13
6.1 New Installation Inspection .....	13
6.2 Routine Visual Inspection .....	13
6.3 Routine Physical Inspection .....	13
6.4 Blade Replacement Inspection .....	14
6.5 Blade Replacement Instructions .....	15
6.6 Maintenance Log .....	17
6.6 Cleaner Maintenance Checklist .....	18
<b>Section 7 - Troubleshooting</b> .....	19
<b>Section 8 - Specs and CAD Drawings</b> .....	20
8.1 Specs and Guidelines .....	20
8.2 CAD Drawings .....	21,22
<b>Section 9 - Replacement Parts</b> .....	23
9.1 Replacement Parts List .....	23
<b>Section 10 - Other Flexco Conveyor Products</b> .....	27

# Section 1 - Important Information

---

## 1.1 General Introduction

We at Flexco are very pleased that you have selected the EZP-LS Primary Cleaner for your conveyor system.

This manual will help you to understand the operation of this product and assist you in making it work up to its maximum efficiency over its lifetime of service.

It is essential for safe and efficient operation that the information and guidelines presented be properly understood and implemented. This manual will provide safety precautions, installation instructions, maintenance procedures and troubleshooting tips.

If, however, you have any questions or problems that are not covered, please visit our web site or contact our Customer Service Department:

**Customer Service: 612-8818-2000**

**Visit [www.flexco.com](http://www.flexco.com) for other Flexco locations and products.**

Please read this manual thoroughly and pass it on to any others who will be directly responsible for installation, operation and maintenance of this cleaner. While we have tried to make the installation and service tasks as easy and simple as possible, it does however require correct installation and regular inspections and adjustments to maintain top working condition.

## 1.2 User Benefits

Correct installation and regular maintenance will provide the following benefits for your operation:

- Reduced conveyor downtime
- Reduced man-hour labor
- Lower maintenance budget costs
- Increased service life for the belt cleaner and other conveyor components

## 1.3 Service Option

The EZP-LS Primary Cleaner is designed to be easily installed and serviced by your on-site personnel. However, if you would prefer complete turn-key factory service, please contact your local Flexco Field Engineer or your Flexco Distributor.

# Section 2 - Safety Considerations and Precautions

---

Before installing and operating the EZP-LS Primary Cleaner, it is important to review and understand the following safety information.

There are set-up, maintenance and operational activities involving both **stationary** and **operating** conveyors. Each case has a safety protocol.

---

## 2.1 Stationary Conveyors

The following activities are performed on stationary conveyors:

- Installation
- Blade replacement
- Repairs
- Tension adjustments
- Cleaning

### **DANGER**

It is imperative that Lockout/Tagout (LOTO) regulations, be followed before undertaking the preceding activities. Failure to use LOTO exposes workers to uncontrolled behavior of the belt cleaner caused by movement of the conveyor belt. Severe injury or death can result.

#### **Before working:**

- Lockout/Tagout the conveyor power source
- Disengage any takeups
- Clear the conveyor belt or clamp securely in place

### **WARNING**

#### **Use Personal Protective Equipment (PPE):**

- Safety eyewear
- Hardhats
- Safety footwear

Close quarters, springs and heavy components create a worksite that compromises a worker's eyes, feet and skull.

PPE must be worn to control the foreseeable hazards associated with conveyor belt cleaners. Serious injuries can be avoided.

---

## 2.2 Operating Conveyors

There are two routine tasks that must be performed while the conveyor is running:

- Inspection of the cleaning performance
- Dynamic troubleshooting

### **DANGER**

Every belt cleaner is an in-running nip hazard. Never touch or prod an operating cleaner. Cleaner hazards cause instantaneous amputation and entrapment.

### **WARNING**

Belt cleaners can become projectile hazards. Stay as far from the cleaner as practical and use safety eyewear and headgear. Missiles can inflict serious injury.

### **WARNING**

Never adjust anything on an operating cleaner. Unforseeable belt projections and tears can catch on cleaners and cause violent movements of the cleaner structure. Flailing hardware can cause serious injury or death.

## Section 3 - Pre-installation Checks and Options

---

### 3.1 Checklist

- Check that the cleaner size is correct for the beltline width
- Check the belt cleaner carton and make sure all the parts are included
- Review the “Tools Needed” list on the top of the installation instructions
- Check the conveyor site:
  - Will the cleaner be installed on a chute
  - Is the install on an open head pulley requiring mounting structure (see 3.3 - Optional Installation Accessories)
  - Are there obstructions that may require cleaner location adjustments (see 3.2 - Cleaner Location Adjustments)

# Section 3 - Pre-installation Checks and Options

## 3.2 Cleaner Location Adjustments

In certain applications it is necessary to modify the location of the primary cleaner pole due to permanent obstacles that obstruct the desired location. Relocating the pole location can be done easily and does not hinder the performance of the cleaner as long as the "C" dimension is maintained.

**NOTE:** In the following example we will be lowering the pole location in the "Y" direction, but the same method could also be applied in the "X" direction.

Conveyor situation:

Pulley Diameter: 300mm  
X=155mm  
Y=140mm  
C=210mm

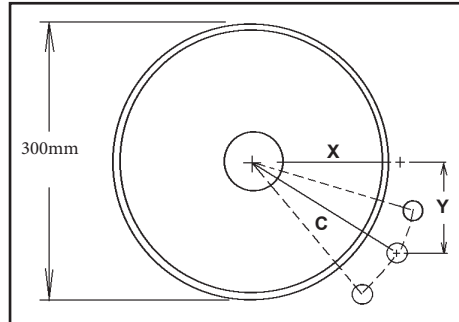

1. **Determine the given location dimensions and define the change needed.** After laying out the given X & Y dimensions, determine the distance of the modification required for adequate clearance of the pole and tensioning system. (In the example we decide to lower the pole 50mm to clear the support structure).
2. **Write down known dimensions.** We can now determine two of the three required dimensions which will allow us to find the third. We know we cannot alter the "C" dimension, so this will remain the same. Also we are required to lower the unit in the "Y" dimension 50mm, so we add 50mm to the given "Y" dimension.

X = ?"

Y = 140mm + 50mm = 190mm

C = 210mm

3. **Determine final dimension.** On a flat vertical surface, using a level, draw one horizontal line and one vertical line, creating a right triangle (Fig 3a). Measure down from the intersection the determined "Y" dimension and mark (Fig 3b). With the tape measure starting at the modified "Y" mark, swing the tape across the "X" line and mark at the "C" dimension where it crosses the "X" line (Fig 3c). Measure from the intersection to the "C" intersection and this will be your new "X" dimension (Fig. 3d).

X = 89mm

Y = 190mm

C = 210mm

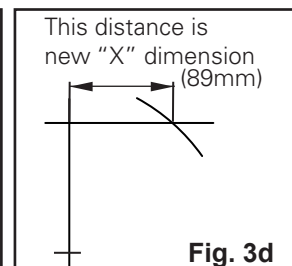
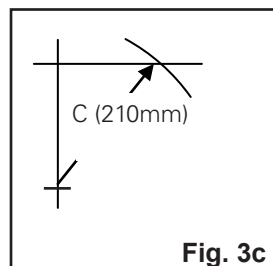
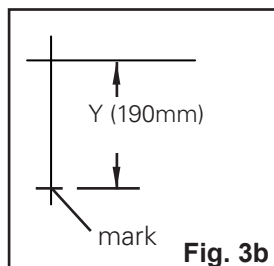
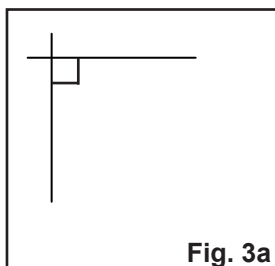

# Section 3 - Pre-Installation Checks and Options (cont.)

## 3.3 Correct Blade Installation and Tensioning

For optimal cleaning efficiency and long wear life, the ConShear™ LS blade must be located and tensioned correctly on the belt head pulley. If the cleaner pole is in the wrong location the performance of the new blade may be adversely affected. See "Possible Problems" below. For tensioning, please follow these instructions.

### Correct Location:

When blade contact is made against the head pulley (prior to tensioning) there should be a 1.5mm to 3mm gap at the bottom of the blade face (Fig. 1).

### Possible Problems:

- Pole location too far out - The initial blade/belt contact gap will be larger than 3mm (Fig. 2). If the blade is correctly tensioned it may flip through before it is fully worn. If tensioned too lightly, it will develop the "smile effect" quickly and not clean properly.
- Pole location too far in - If there is no gap at the initial blade/belt contact (Fig. 3), the tip of the blade may not be touching the belt. In this case, the blade will push away and lose its shearing (cleaning) effect. The blade may also develop a flap at the tip which may trap material.

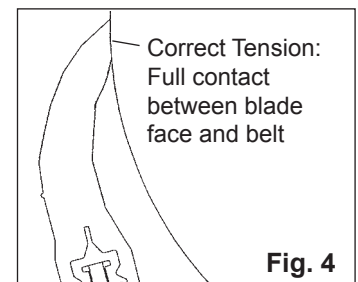
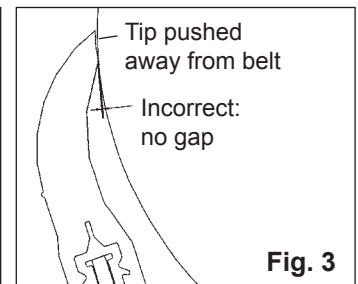
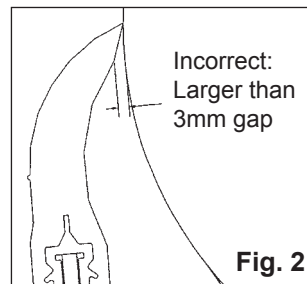
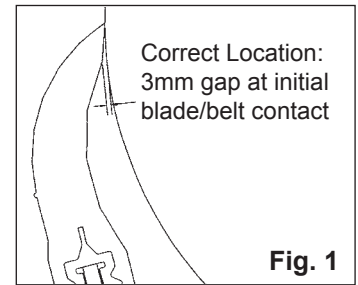

### Correct Tensioning:

The blade should be tensioned until the gap is gone (Fig. 4).

### The Material Path Option™

For optimal cleaning and reduced blade retensioning, the cleaner blade width should be sized to fit the material path of the belt. The material path is typically the centre 2/3 of the belt width. Choosing a blade only slightly wider than the material path can decrease differential blade wear which reduces blade retensioning maintenance, as well as reducing the frequency of blade replacement.

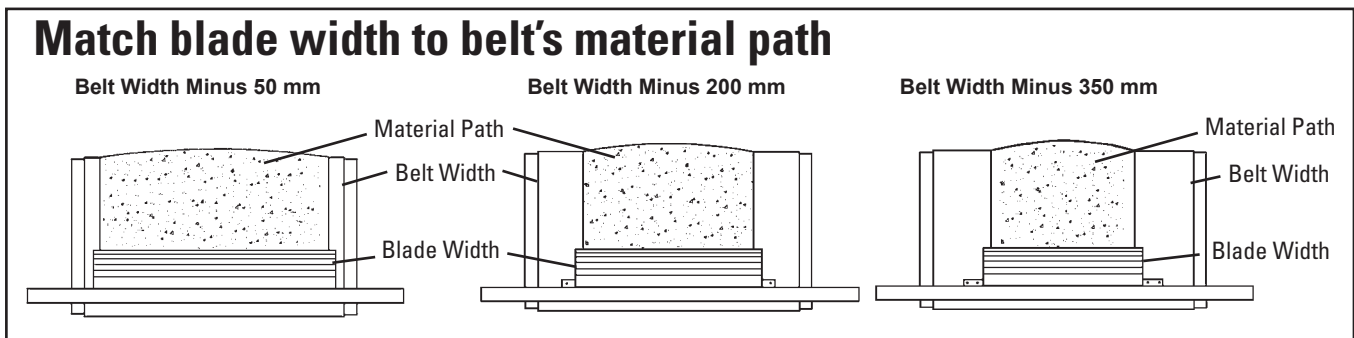



# Section 4 - Installation Instructions - EZP-LS

## Limited Space Primary Cleaner

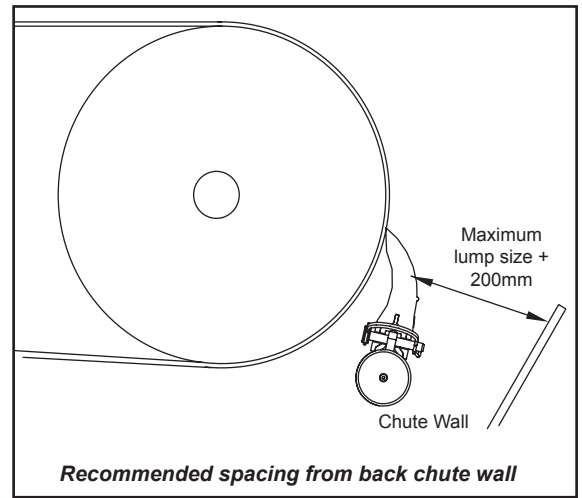
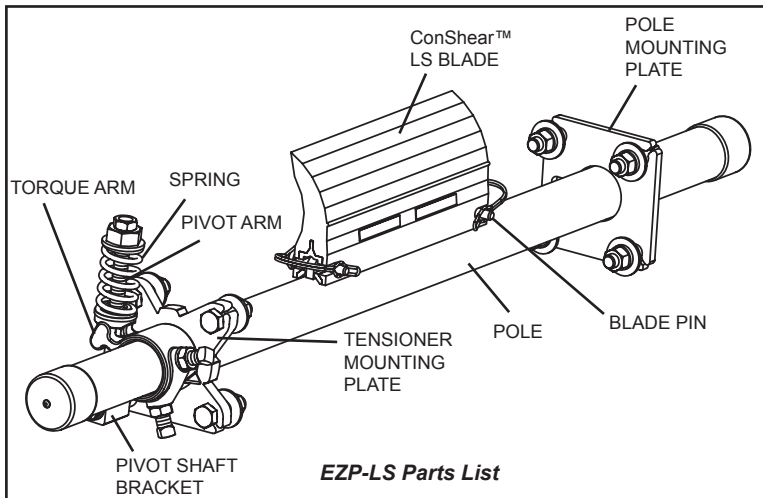

**PHYSICALLY LOCK OUT AND TAG THE CONVEYOR AT THE POWER SOURCE BEFORE YOU BEGIN CLEANER INSTALLATION.**

Installation specs and instructions are based on the assumption that the conveyor is in its working position (angle). If the conveyor angle will be different, the cleaner should be installed per the final position.

**Tools Needed:**

- Tape measure
- Level
- 19mm combination wrench
- Ratchet with 19mm socket
- Marking pen or soapstone
- Adjustable pliers
- Large adjustable wrench (to at least 28mm)
- Torch or welder

**Pole Location Chart Metric**

A	X	Y	C
150	65	140	150
175	81	140	155
200	96	140	162
225	109	140	171
250	125	140	179
275	138	140	189
300	153	140	198
325	166	140	209
350	178	140	219
375	191	140	229
400	206	140	239
425	219	140	252
450	231	140	263
475	244	140	273
500	256	140	284
525	269	140	295
550	281	140	307

- Find the dimensions for the correct pole location.** Measure the pulley diameter (see Fig. 1). Find this pulley size (A) on the chart at right and determine the correct X, Y and C dimensions. Measure the X dimension horizontally from the centre of the pulley shaft and make a mark. From that mark, draw a long vertical line down, then measure and mark Dim Y. This indicates the location of the centre of the pole. Draw an extended horizontal line through this mark. Measure and mark the other side. NOTE: Adjustments can be made to the X and Y coordinates to move away from obstacles as long as the C dimension remains constant. See Section 3.2. For open head installs, first add mounting support materials to the structure.

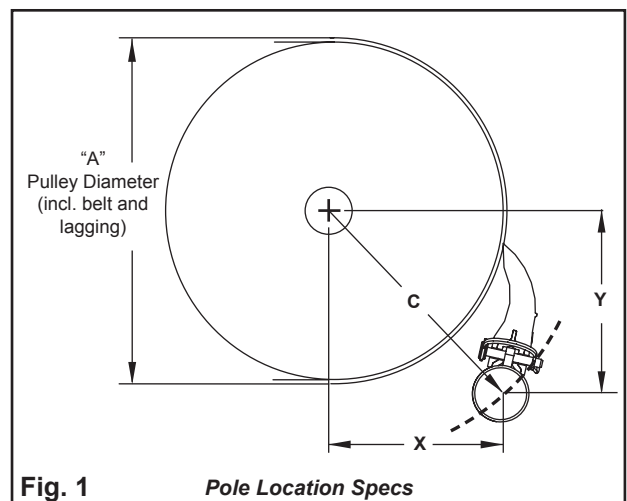

# Section 4 – Installation Instructions (cont.)

- 2. Mark and cut the mounting plate holes.** Using the template provided in the instruction packet, position the pole access hole on the chute, aligning the hole notches with the layout lines. Position the keyway toward the pulley. Trace the pole cutout and mounting holes (Fig. 2). Cut the holes on both sides of the chute.
- NOTE: Hole cutouts are slotted for later adjustment if needed.

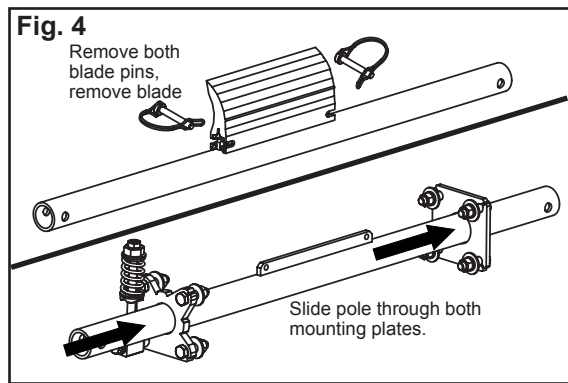
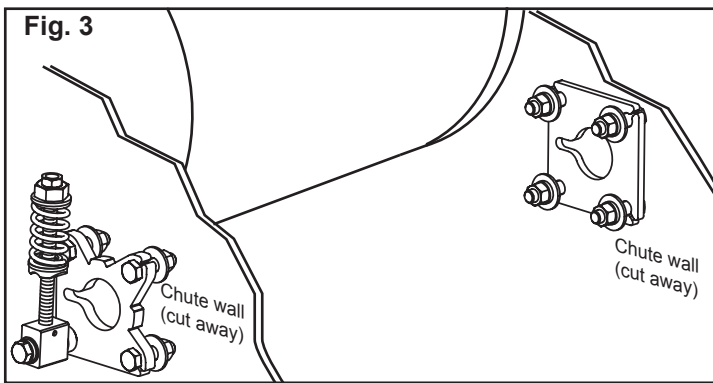
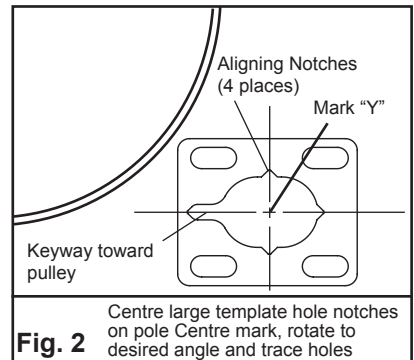

- 3. Install the mounting plates.** Bolt the tensioner mounting plate on the side with the tensioner and the pole mounting plate on the opposite side. Centre the plates on the slotted holes and tighten the bolts (Fig. 3).
- 4. Install the pole.** Remove both blade pins and the blade from the pole, and insert the pole through both mounting plates (Fig. 4).
- 5. Centre the cleaner on the belt.** Reinstall the blade with both blade pins. Centre the blade on the belt (Fig. 5a). Rotate the blade up to the belt and check to insure that the blade is square to the pulley face. If it is not, loosen a mounting plate on one side and adjust the plate forward or backward to square the blade to the pulley, and retighten the bolts (Fig 5b.)

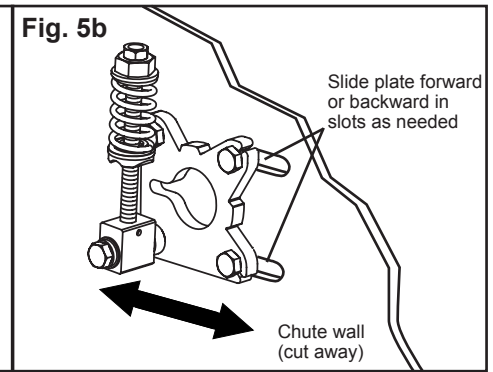
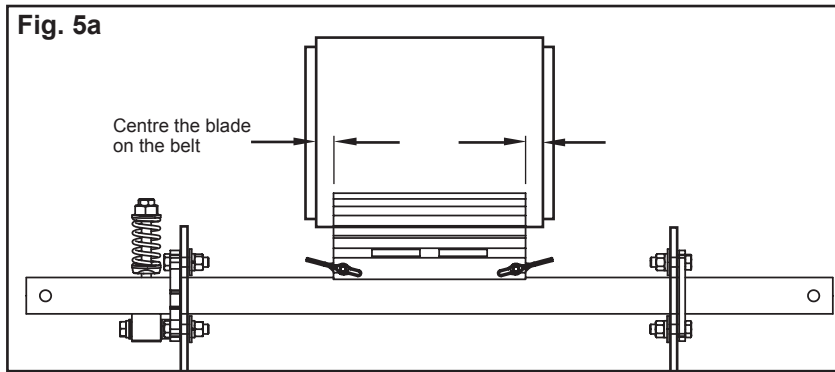

## Section 4 – Installation Instructions (cont.)

- 6. Install the tensioner.** Slide the torque arm onto the pole (Fig. 6a). **IMPORTANT:** To ensure the torque arm is installed correctly, note that the arm must fit snugly up to the mounting plate and the pointer **must** be to the inside. To correctly position the torque arm, rotate the pole until the blade contacts the belt. **Then align the torque arm pointer to notch “A” (Fig. 6b or 6c). There will be a 25mm gap between the pivot block and the torque arm nub if the tensioner is installed correctly.** While holding the blade firmly against the belt, tighten the set screws.

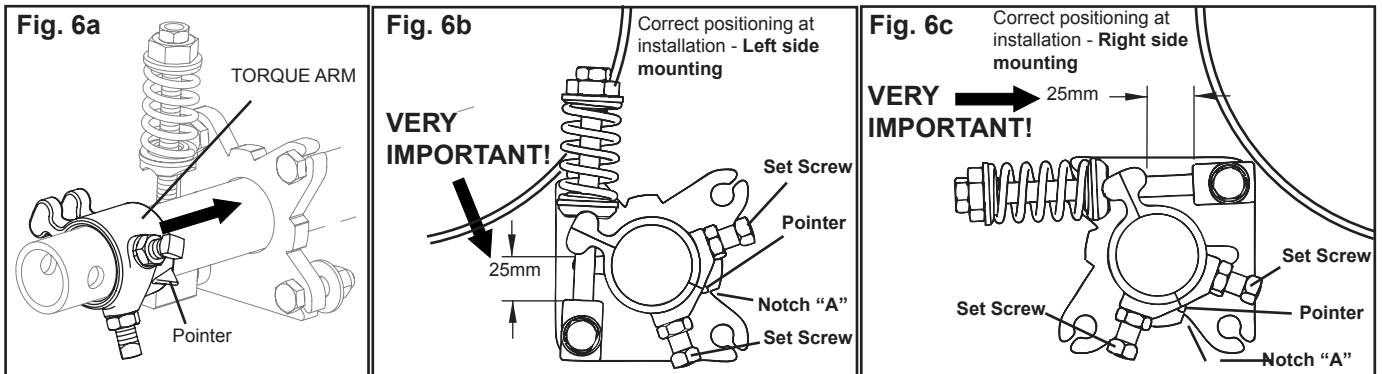

- 7. Set the blade tension.** Make sure that the nubs on the torque arm are seated into the groove in the pivot washer (Fig. 7). Turn the tension nut so that enough pressure is applied to keep the pivot washer seated in the torque arm. Now, using a wrench, turn the tension nut until the spring is compressed to the length dimension specified in the spring length chart below.

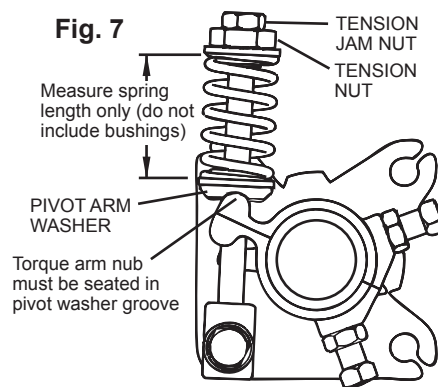

**Spring Length Chart**

BLADE WIDTH	PURPLE SPRING		WHITE SPRING		SILVER SPRING		
	mm	in.	mm	in.	mm	in.	
250	10	51	2	N/A	N/A	N/A	N/A
400	16	41	1 5/8	54	2 1/8	N/A	N/A
550	22	N/A	N/A	51	2	N/A	N/A
700	28	N/A	N/A	48	1 7/8	N/A	N/A
850	34	N/A	N/A	44	1 3/4	N/A	N/A
1000	40	N/A	N/A	38	1 1/2	N/A	N/A
1150	46	N/A	N/A	35	1 3/8	51	2
1300	52	N/A	N/A	N/A	N/A	51	2
1450	58	N/A	N/A	N/A	N/A	48	1 7/8

Shading indicates preferred spring option

- 8. Confirm the correct pole location.** After the cleaner is installed, slide the Pole Location Gauge (provided in the instruction packet) between the pole and the pulley until it stops at a step (Fig. 8a). Read the flat area where the pole is resting. This diameter reading should be equal to the Dim. A (pulley diameter) used in Step 1. **NOTE:** If the diameter reading on the gauge is not the same as Dim. A in Step 1, check the “C” dimension and correct accordingly.

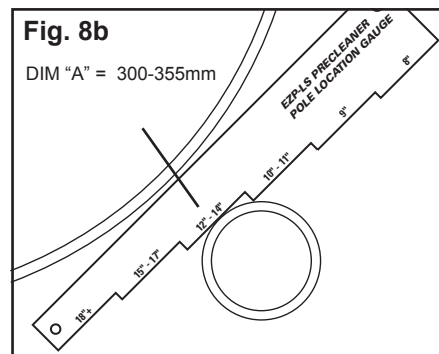
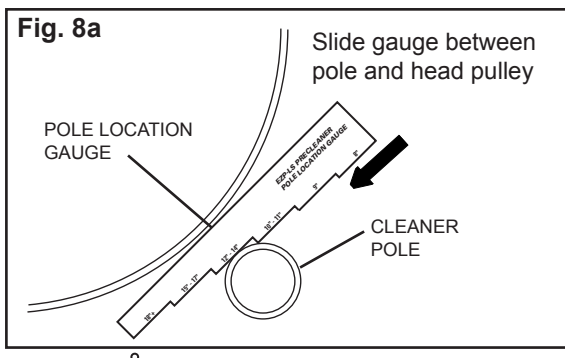

- 9. Add pole caps.** Put a urethane cap on each pole end.

- 10. Test run the conveyor and inspect the performance.** If vibration occurs or more cleaning efficiency is desired, make tensioning adjustments. (Also, check the Troubleshooting Guide.)

# Section 5 - Pre-Operation Checklist and Testing

---

## 5.1 Pre-Op Checklist

- Recheck that all fasteners are tightened properly
- Add pole caps
- Apply all supplied labels to the cleaner
- Check the blade location on the belt
- Be sure that all installation materials and tools have been removed from the belt and the conveyor area

## 5.2 Test Run the Conveyor

- Run the conveyor for at least 15 minutes and inspect the cleaning performance
- Check the tensioner spring for recommended length (proper tensioning)
- Make adjustments as necessary

**NOTE:** Observing the cleaner when it is running and performing properly will help to detect problems or when adjustments are needed later.

# Section 6 - Maintenance

---

Flexco belt cleaners are designed to operate with minimum maintenance. However, to maintain superior performance some service is required. When the cleaner is installed a regular maintenance program should be set up. This program will ensure that the cleaner operates at optimal efficiency and problems can be identified and fixed before the cleaner stops working.

All safety procedures for inspection of equipment (stationary or operating) must be observed. The EZP-LS Primary Cleaner operates at the discharge end of the conveyor and is in direct contact with the moving belt. Only visual observations can be made while the belt is running. Service tasks can be done only with the conveyor stopped and by observing the correct lockout/tagout procedures.

## 6.1 New Installation Inspection

After the new cleaner has run for a few days a visual inspection should be made to ensure the cleaner is performing properly. Make adjustments as needed.

## 6.2 Routine Visual Inspection (every 2-4 weeks)

A visual inspection of the cleaner and belt can determine:

- If the spring length is the correct length for optimal tensioning
- If the belt looks clean or if there are areas that are dirty
- If the blade is worn out and needs to be replaced
- If there is damage to the blade or other cleaner components
- If fugitive material is built up on the cleaner or in the transfer area
- If there is cover damage to the belt
- If there is vibration or bouncing of the cleaner on the belt
- If a snub pulley is used, a check should be made for material buildup on the pulley

If any of the above conditions exist, a determination should be made on when the conveyor can be stopped for cleaner maintenance.

## 6.3 Routine Physical Inspection (every 6-8 weeks)

When the conveyor is not in operation and properly locked and tagged out a physical inspection of the cleaner to perform the following tasks:

- Clean material buildup off of the cleaner blade and pole
- Closely inspect the blade for wear and any damage. Replace if needed.
- Check both blade pins for proper installation and condition. Replace if needed.
- Ensure full blade to belt contact
- Inspect the cleaner pole for damage
- Inspect all fasteners for tightness and wear. Tighten or replace as needed.
- Replace any worn or damaged components
- Check the tension of the cleaner blade to the belt. Adjust the tension if necessary using the chart on the cleaner or the one on Page 9.
- When maintenance tasks are completed, test run the conveyor to ensure the cleaner is performing properly

# Section 6 - Maintenance

## 6.4 Blade Replacement Inspection

The EZP-LS Primary Cleaner has a built-in blade wear gauge to make it easy to determine when the blade is worn out and needs to be replaced. A pointer on the torque arm is set up when a new blade is installed to point at "Notch A" on the mounting plate (Fig. A). When the blade is worn out the pointer will point to "Notch B" (Fig. B).

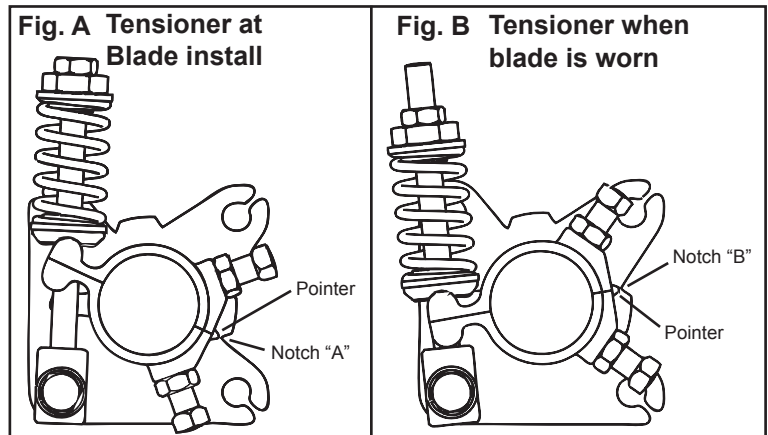

If the pointer is difficult to see, you can also check the blade wear by looking at the gap between the torque arm nub and the pivot block. At new blade install, the gap will be 25mm (Fig. C). When the blade is completely worn out and needs to be changed, there will be no gap (Fig. D).

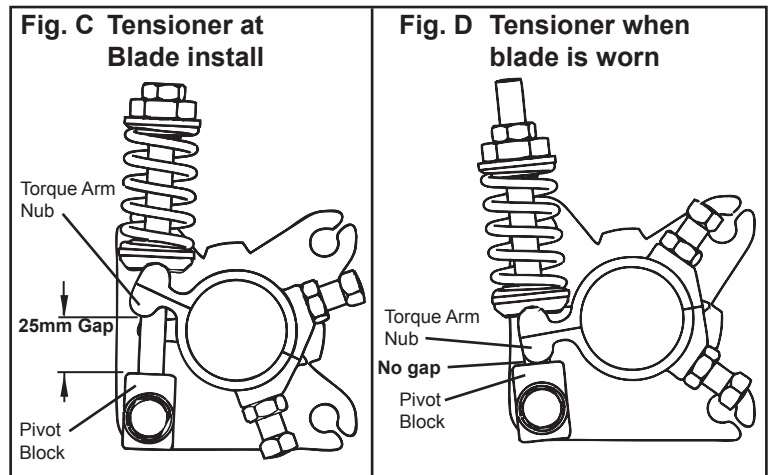

# Section 6 - Maintenance

## 6.5 Blade Replacement Instructions

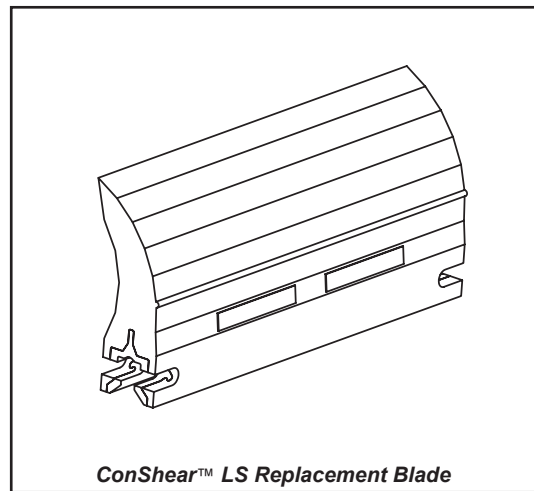
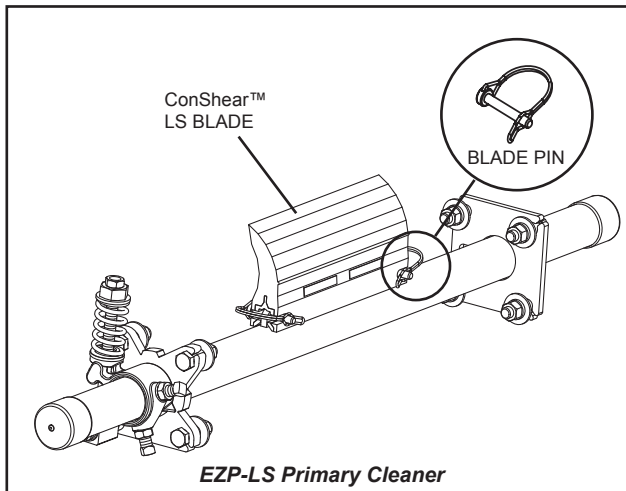

**PHYSICALLY LOCK OUT AND TAG THE CONVEYOR AT THE POWER SOURCE BEFORE YOU BEGIN CLEANER MAINTENANCE.**

- Tools Needed:**
- Tape measure
  - (2) crescent wrenches (or 28mm wrenches)
  - Wire brush (for cleaning pole)
  - Small putty knife (for cleaning pole)

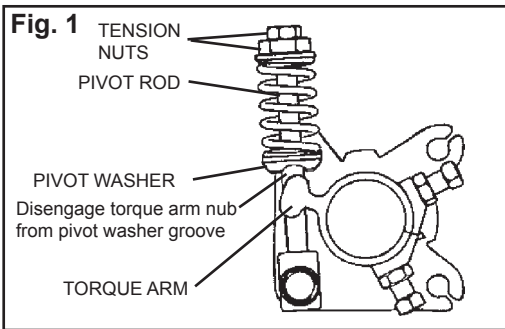

**1. Remove the tension.** Move both tension nuts to the end of the pivot rod (Fig. 1). Move the pivot rod and spring from the torque arm so the nub disengages from the pivot washer. The pole can now rotate down freely. This releases the tension of the blade on the belt.

**2. Remove the worn blade.** Remove one blade pin and remove the blade from the pole (Fig. 2). Clean all fugitive material from the pole. **NOTE:** If blade is hard to remove use a screwdriver or hammer to loosen it and then remove.

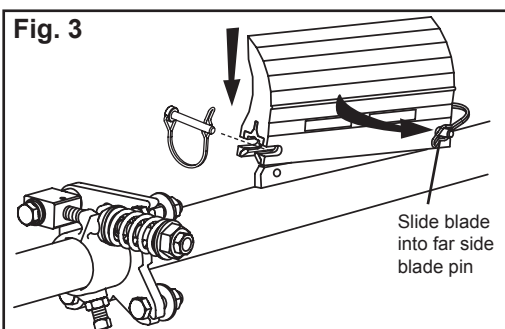
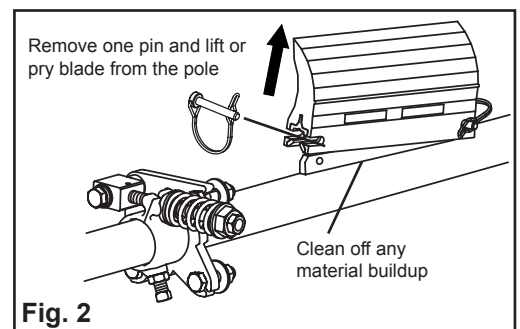

**3. Install the new blade.** Slide the new blade onto the pole, locking it into the far blade pin, then reinstall the removed blade pin (Fig. 3). **NOTE:** Be sure the blade pin head is installed facing the belt.

# Section 6 - Maintenance

## 6.5 Blade Replacement Instructions (cont.)

**4. Reset the correct blade tension.** While holding the blade against the belt, make sure the pointer is pointing to Notch "A" and that there is a 25mm gap between the pivot block and the torque arm nub (Fig. 4a). Re-engage the pivot rod washer groove with the nub on the torque arm and turn the tension nuts until the correct spring length is achieved (Fig. 4b). Measure the length of the spring only (do not include the bushings).

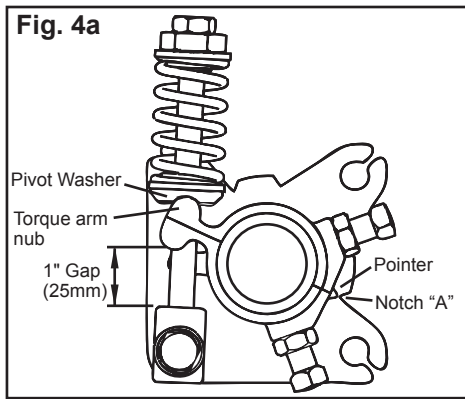

**Spring Length Chart**

BLADE WIDTH		PURPLE SPRING		WHITE SPRING		SILVER SPRING	
mm	in.	mm	in.	mm	in.	mm	in.
250	10	51	2	N/A	N/A	N/A	N/A
400	16	41	1 5/8	54	2 1/8	N/A	N/A
550	22	N/A	N/A	51	2	N/A	N/A
700	28	N/A	N/A	48	1 7/8	N/A	N/A
850	34	N/A	N/A	44	1 3/4	N/A	N/A
1000	40	N/A	N/A	38	1 1/2	N/A	N/A
1150	46	N/A	N/A	35	1 3/8	51	2
1300	52	N/A	N/A	N/A	N/A	51	2
1450	58	N/A	N/A	N/A	N/A	48	1 7/8

Shading indicates preferred spring option

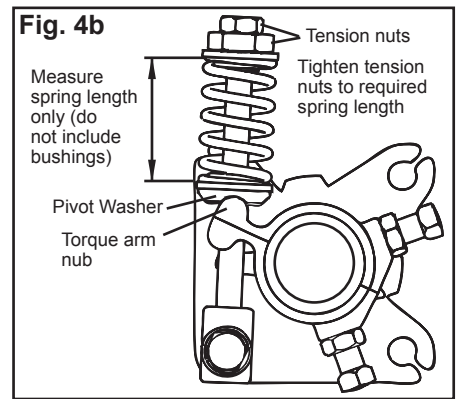

**Test run the cleaner.** Run the conveyor for at least 15 minutes and inspect the cleaning performance. Check the spring length for proper tensioning. Make adjustments as necessary.



# Section 6 - Maintenance (cont.)

---

## 6.6 Maintenance Log

Conveyor Name/No. \_\_\_\_\_

Date: \_\_\_\_\_ Work done by: \_\_\_\_\_ Service Quote #: \_\_\_\_\_

Activity: \_\_\_\_\_

---

Date: \_\_\_\_\_ Work done by: \_\_\_\_\_ Service Quote #: \_\_\_\_\_

Activity: \_\_\_\_\_

---

Date: \_\_\_\_\_ Work done by: \_\_\_\_\_ Service Quote #: \_\_\_\_\_

Activity: \_\_\_\_\_

---

Date: \_\_\_\_\_ Work done by: \_\_\_\_\_ Service Quote #: \_\_\_\_\_

Activity: \_\_\_\_\_

---

Date: \_\_\_\_\_ Work done by: \_\_\_\_\_ Service Quote #: \_\_\_\_\_

Activity: \_\_\_\_\_

---

Date: \_\_\_\_\_ Work done by: \_\_\_\_\_ Service Quote #: \_\_\_\_\_

Activity: \_\_\_\_\_

---

Date: \_\_\_\_\_ Work done by: \_\_\_\_\_ Service Quote #: \_\_\_\_\_

Activity: \_\_\_\_\_

---

# Section 6 - Maintenance (cont.)

## 6.6 Cleaner Maintenance Checklist

Blade Width:  Belt minus 2" (50mm)  Belt minus 8" (200mm)  Belt minus 14" (355mm)

**Beltline Information:**

Beltline Number: \_\_\_\_\_ Belt Condition: \_\_\_\_\_

Belt Width:  300mm  450mm  600mm  750mm  900mm  1050mm  1200mm  1350mm  1500mm

Head Pulley Diameter (Belt & Lagging): \_\_\_\_\_ Belt Speed: \_\_\_\_\_ fpm Belt Thickness: \_\_\_\_\_

Belt Splice \_\_\_\_\_ Condition of Splice \_\_\_\_\_ Number of splices \_\_\_\_\_  Skived  Unskived

Material conveyed \_\_\_\_\_

Days per week run \_\_\_\_\_ Hours per day run \_\_\_\_\_

**Blade Life:**

Date blade installed: \_\_\_\_\_ Date blade inspected: \_\_\_\_\_ Estimated blade life: \_\_\_\_\_

Is blade making complete contact with belt?  Yes  No

Distance from wear line: LEFT \_\_\_\_\_ MIDDLE \_\_\_\_\_ RIGHT \_\_\_\_\_

Blade condition:  Good  Grooved  Smiled  Not contacting belt  Damaged

Measurement of spring: Required \_\_\_\_\_ Currently \_\_\_\_\_

**Was Cleaner Adjusted:**  Yes  No

**Pole Condition:**  Good  Bent  Worn

**Lagging:**  Slide lag  Ceramic  Rubber  Other  None

Condition of lagging:  Good  Bad  Other \_\_\_\_\_

**Cleaner's Overall Performance:** ( Rate the following 1 - 5, 1=very poor - 5= very good )

Appearance:  Comments: \_\_\_\_\_

Location:  Comments: \_\_\_\_\_

Maintenance:  Comments: \_\_\_\_\_

Performance:  Comments: \_\_\_\_\_

**Other Comments:** \_\_\_\_\_

\_\_\_\_\_

\_\_\_\_\_

\_\_\_\_\_

\_\_\_\_\_

# Section 7 - Troubleshooting

<b>Problem</b>	<b>Possible Cause</b>	<b>Possible Solutions</b>
Poor cleaning performance	Cleaner under-tensioned	Adjust to correct tension - see spring length chart
	Cleaner over-tensioned	Adjust to correct tension - see spring length chart
	Cleaner installed in wrong location	Verify "C" dimension, relocate to correct dimension
	Cleaner blade worn or damaged	Replace cleaner blade
Rapid Blade Wear	Tension on cleaner too high/low	Adjust to correct tension - see spring length chart
	Cleaner not located correctly	Check cleaner location for correct dimensions
	Blade attack angle incorrect	Check cleaner location for correct dimensions
	Material too abrasive for blade	Option: switch to alternate cleaner with metal blades
	Mechanical splice damaging blade	Repair, skive or replace splice
Centre wear on blade (smile effect)	Blade wider than material path	Replace blade with width to match material path
	Tension on cleaner too high/low	Adjust to correct tension - see spring length chart
Unusual wear or damage to blade	Mechanical splice damaging blade	Repair, skive or replace splice
	Belt damaged or ripped	Repair or replace belt
	Cleaner not correctly located	Verify "C" dimension, relocate to correct dimension
	Damage to pulley or pulley lagging	Repair or replace pulley
Vibration or noise	Cleaner not located correctly	Verify "C" dimension, relocate to correct dimension
	Blade attack angle incorrect	Verify "C" dimension, relocate to correct dimension
	Cleaner running on empty belt	Use a spray pole when the belt is empty
	Cleaner tension too high/low	Adjust to correct tension or slight adjust to diminish
	Cleaner locking bolts not secure	Check and tighten all bolts and nuts
	Cleaner not square to head pulley	Verify "C" dimension, relocate to correct dimension
	Material buildup in chute	Clean up build-up on cleaner and in chute
Cleaner being pushed away from pulley	Cleaner tension not set correctly	Ensure correct tension/increase tension slightly
	Sticky material is overburdening cleaner	Increase tension; replace with cleaner with metal tips; replace with larger size cleaner
	Cleaner not set up correctly	Confirm location dimensions are equal on both sides

# Section 8 - Specs and CAD Drawings

## 8.1 Specs and Guidelines

### Pole Length Specifications

CLEANER SIZE		POLE LENGTH		MAXIMUM CONVEYOR SPAN	
mm	in.	mm	in.	mm	in.
300	12	1050	42	925	37
450	18	1200	48	1075	43
600	24	1350	54	1225	49
750	30	1500	60	1375	55
900	36	1650	66	1525	61
1050	42	1800	72	1675	67
1200	48	1950	78	1825	73
1350	54	2200	88	2075	83
1500	60	2350	94	2225	89

Pole Diameter - 48 mm

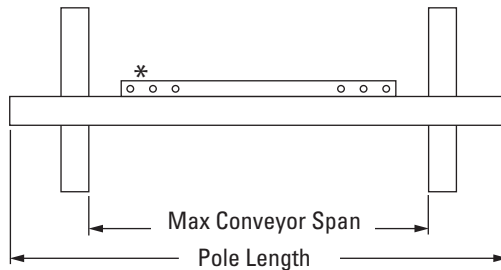

\*Each pole size can be used with a blade size either belt width minus 50mm, belt width minus 200mm, or belt width minus 350mm.

### Clearance Guidelines for Installation

HORIZONTAL CLEARANCE REQUIRED		VERTICAL CLEARANCE REQUIRED	
mm	in.	mm	in.
75	3	165	6 1/2

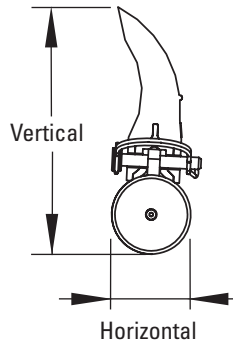

### Pole Location Specs

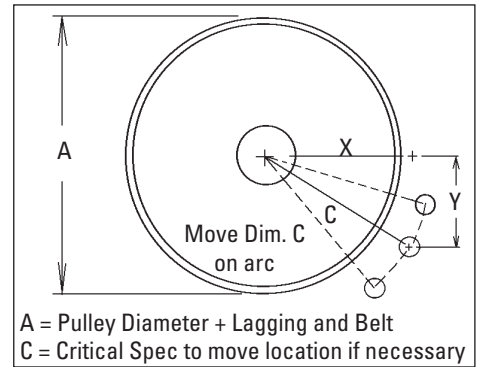

A = Pulley Diameter + Lagging and Belt  
C = Critical Spec to move location if necessary

### Spring Length Chart

BLADE WIDTH		PURPLE SPRING		WHITE SPRING		SILVER SPRING	
mm	in.	mm	in.	mm	in.	mm	in.
250	10	51	2	N/A	N/A	N/A	N/A
400	16	41	1 5/8	54	2 1/8	N/A	N/A
550	22	N/A	N/A	51	2	N/A	N/A
700	28	N/A	N/A	48	1 7/8	N/A	N/A
850	34	N/A	N/A	44	1 3/4	N/A	N/A
1000	40	N/A	N/A	38	1 1/2	N/A	N/A
1150	46	N/A	N/A	35	1 3/8	51	2
1300	52	N/A	N/A	N/A	N/A	51	2
1450	58	N/A	N/A	N/A	N/A	48	1 7/8

Shading indicates preferred spring option

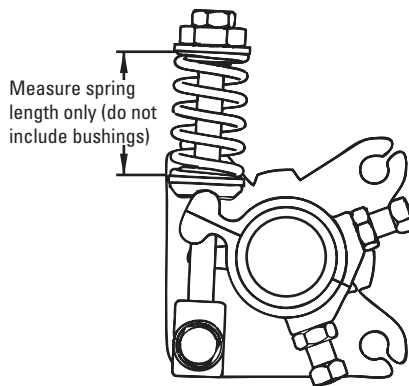

### Pole Location Chart - Metric

A	X	Y	C
150	65	140	150
175	81	140	155
200	96	140	162
225	109	140	171
250	125	140	179
275	138	140	189
300	153	140	198
325	166	140	209
350	178	140	219
375	191	140	229
400	206	140	239
425	219	140	252
450	231	140	263
475	244	140	273
500	256	140	284
525	269	140	295
550	281	140	307

### Specifications:

- Maximum Belt Speed ..... 2.5M/sec
- Temperature Rating (ConShear)..... -35°C to 82°C
- Minimum Pulley Diameter ..... 150mm
- Blade Height ..... 115mm
- Usable Blade Wear Length ..... 60mm
- Blade Material ..... Urethane (proprietary blend for abrasion resistance and long wear)
- Available for Belt Widths..... 300 to 1500mm.
- \* CEMA Cleaner Rating..... Class 2

# Section 8 - Specs and CAD Drawings

## 8.2 CAD Drawings

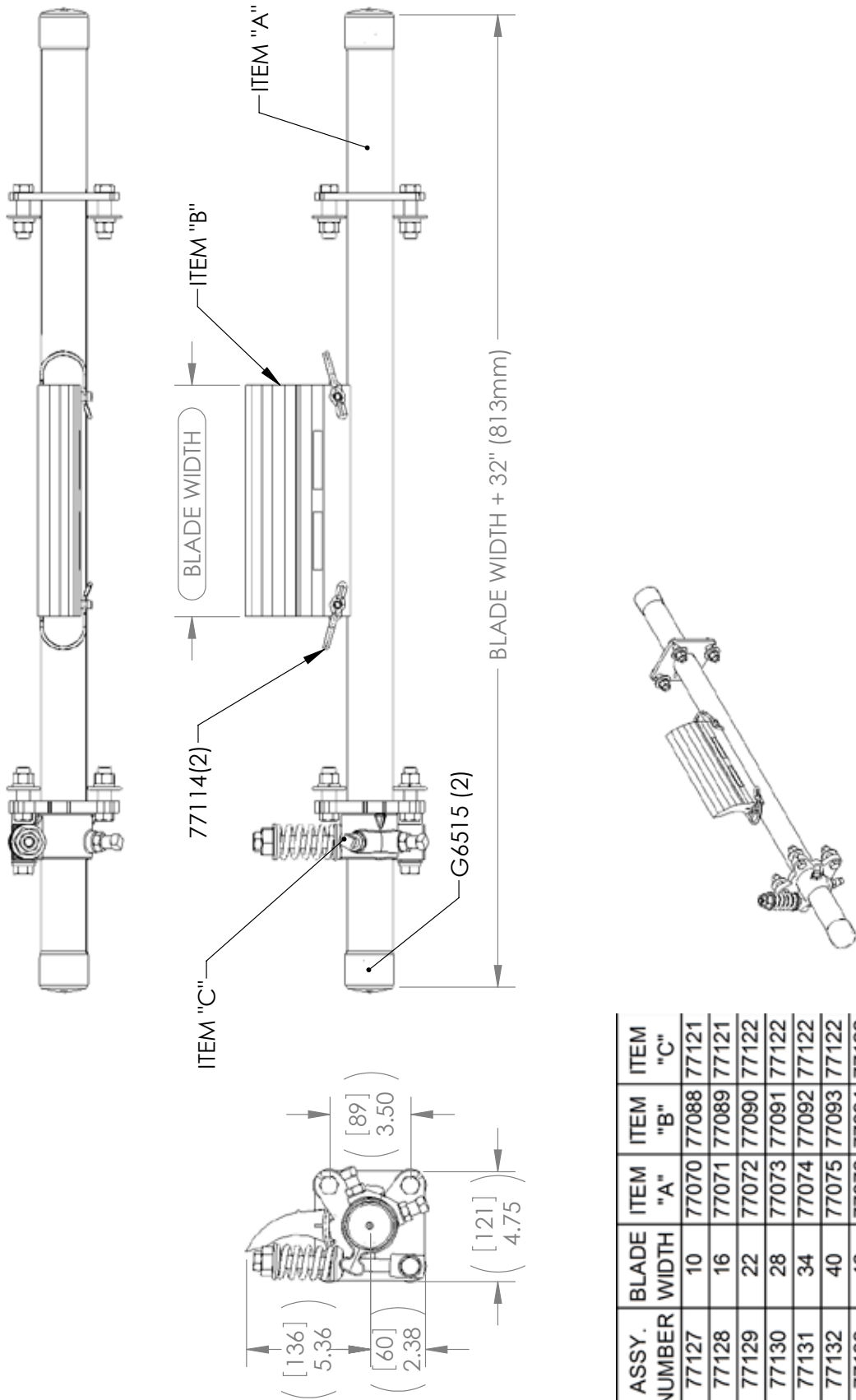

ASSY. NUMBER	BLADE WIDTH	ITEM "A"	ITEM "B"	ITEM "C"
77127	10	77070	77088	77121
77128	16	77071	77089	77121
77129	22	77072	77090	77122
77130	28	77073	77091	77122
77131	34	77074	77092	77122
77132	40	77075	77093	77122
77133	46	77076	77094	77122
77134	52	77077	77095	77123
77135	58	77078	77096	77123

# Section 8 - Specs and CAD Drawings

## 8.2 CAD Drawings

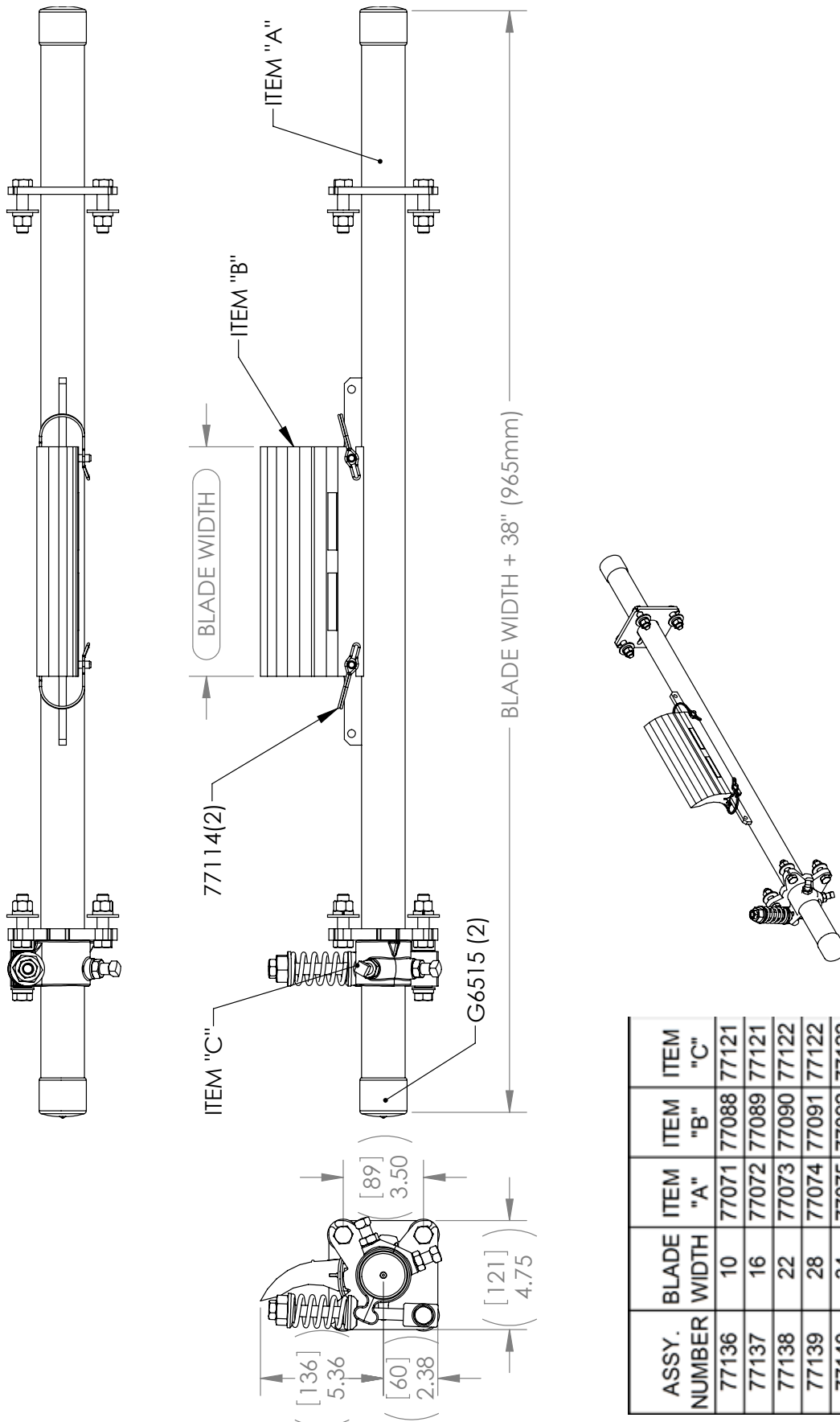

ASSY. NUMBER	BLADE WIDTH	ITEM "A"	ITEM "B"	ITEM "C"
77136	10	77071	77088	77121
77137	16	77072	77089	77121
77138	22	77073	77090	77122
77139	28	77074	77091	77122
77140	34	77075	77092	77122
77141	40	77076	77093	77122
77142	46	77077	77094	77122
77143	52	77078	77095	77123

# Section 9 - Replacement Parts

## 9.1 Replacement Parts List

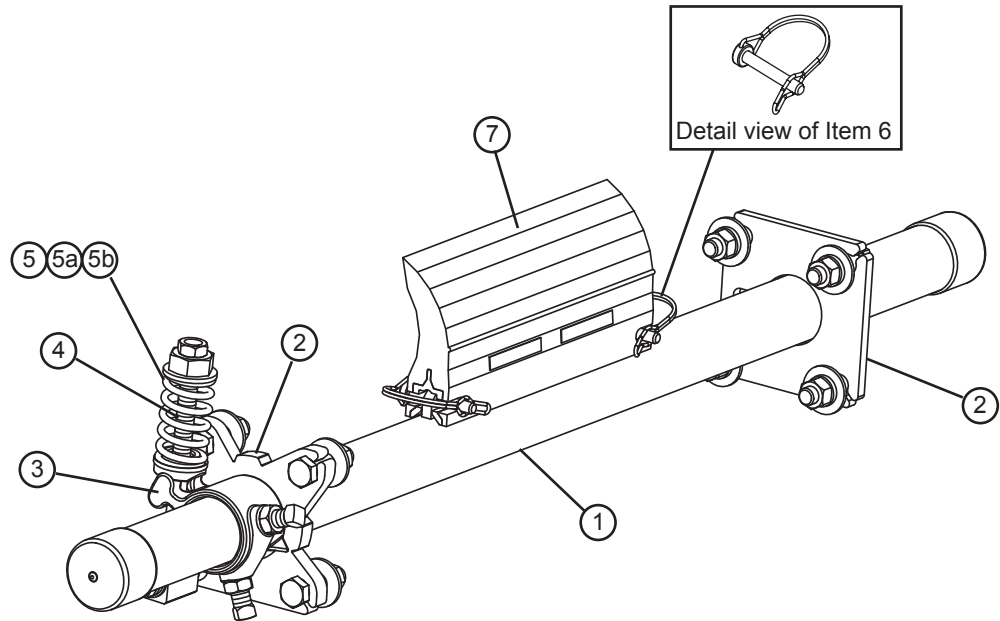

### Replacement Parts

REF	DESCRIPTION	ORDERING NUMBER	ITEM CODE	WT. KGS.
1	300mm (12") Pole	LSP12	77070	2.7
	450mm (18") Pole	LSP18	77071	3.2
	600mm (24") Pole	LSP24	77072	3.6
	750mm (30") Pole	LSP30	77073	4.1
	900mm (36") Pole	LSP36	77074	4.5
	1050mm (42") Pole	LSP42	77075	5.0
	1200mm (48") Pole	LSP48	77076	5.4
	1350mm (54") Pole	LSP54	77077	5.9
1500mm (60") Pole	LSP60	77078	6.4	
2	Mounting Plate Kit* (incl. 1 tensioner mounting plate and 1 pole mounting plate)	LSTMPK	77366	0.7
3	Torque Arm Kit* (1 ea.)	LST-TAK	77120	0.3
4	Pivot Block/Rod Kit* (1 ea.)	LSTPB-RK	77367	0.2
5	Tension Spring - Purple (1 ea.) for blades 250-400mm (10-16")	LS-SP	77365	0.1
5a	Tension Spring - White (1 ea.) for blades 550 - 1150mm (22" - 46")	LS-SW	77117	0.1
5b	Tension Spring - Silver (1 ea.) for blades 1300 - 1450mm (52" - 58")	LS-SS	77118	0.1
6	LS Blade Pin (1 ea.)	LS-BP	77114	0.1
-	LST Spring Tensioner* - Purple incl. 1 tensioner mounting plate and 1 ea. items 3, 4 & 5 for blades 250-400mm (10-16")	LST-P	77121	1.5
-	LST Spring Tensioner* - White incl. 1 tensioner mounting plate and 1 ea. items 3, 4 & 5a for blades 550 - 1150mm (22" - 46")	LST-W	77122	3.4
-	LST Spring Tensioner* - Silver incl. 1 tensioner mounting plate and 1 ea. items 3, 4 & 5b for blades 1300 - 1450mm (52" - 58")	LST-S	77123	3.4

\*Hardware Included

### Replacement ConShear™-LS Blades

REF	BLADE WIDTH		ORDERING NUMBER	ITEM CODE	WT. KGS.
	in.	mm			
7	10	250	CRB-LS10	77088	1.0
	16	400	CRB-LS16	77089	1.5
	22	550	CRB-LS22	77090	2.1
	28	700	CRB-LS28	77091	2.6
	34	850	CRB-LS34	77092	3.2
	40	1000	CRB-LS40	77093	3.8
	46	1150	CRB-LS46	77094	4.4
	52	1300	CRB-LS52	77095	4.9
	58	1450	CRB-LS58	77096	5.5

Order blade width for your belt width's material path: Belt Width Minus 50mm, Belt Width Minus 200mm or Belt Width Minus 350.

### Spring Tensioner Selection Chart

CLEANER BLADE WIDTH	77121 Purple	77122 White	77123 Silver
ConShear-LS 250 - 400mm (10" - 16")	X		
ConShear-LS 550 - 1150mm (22" - 46")		X	
ConShear-LS 1300 - 1450mm (52" - 58")			X

For best results use Flexco Genuine Replacement Blades and Parts.









# Section 10 - Other Flexco Conveyor Products

Flexco provides many conveyor products that help your conveyors to run more efficiently and safely. These components solve typical conveyor problems and improve productivity. Here is a quick overview on just a few of them:

## EZP1 Primary Cleaner



- Patented ConShear™ blade renews its cleaning edge as it wears
- Visual Tension Check™ for optimal blade tensioning and simple retensioning
- Quick and easy one-pin blade replacement
- Material Path Option™ for optimal cleaning and reduced maintenance

## Flexco Slider/Impact Beds



- Adjusting troughing angles for easy installation and adjustability
- Long-wearing UHMW for sealing the load zone
- Offered in both Light & Medium duty designs to affordably fit your application

## MHS Secondary Cleaner with Service Advantage Cartridge

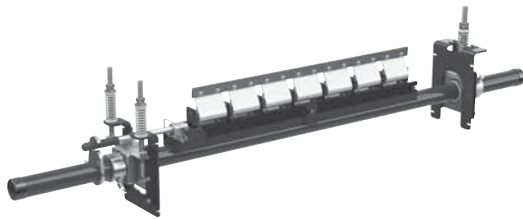

- An easy slide-out cartridge for service
- Cartridge design to speed up blade-change maintenance
- Patented PowerFlex™ Cushions for superior cleaning performance
- Compatible with Flexco mechanical splices

## PT Max™ Belt Trainer



- Patented “pivot & tilt” design for superior training action
- Dual sensor rollers on each side to minimize belt damage
- Pivot point guaranteed not to freeze up
- Available for topside and return side belts

## Flexco Specialty Belt Cleaners



- “Limited space” cleaners for tight conveyor applications
- High Temp cleaners for severe, high heat applications
- A rubber fingered cleaner for chevron and raised rib belts
- Multiple cleaner styles in stainless steel for corrosive applications

## Belt Plows



- A belt cleaner for the tail pulley
- Exclusive blade design quickly spirals debris off the belt
- Economical and easy to service
- Available in vee or diagonal models

## **The Flexco Vision**

To become the leader in maximising belt conveyor productivity for our customers worldwide through superior service and innovation.

Flexco (Aust.) Pty. Ltd • 10 Solent Circuit • Baulkham Hills NSW 2153 • Australia  
Tel: 612-8818-2000 • Fax: 612-8824-6333 • E-mail: [salesau@flexco.com](mailto:salesau@flexco.com)

Visit [www.flexco.com](http://www.flexco.com) for other Flexco locations and products.

©2016 Flexible Steel Lacing Company, 09/12/16. For reorder: X3167

