

Chevron Belt Cleaner

Installation, Operation and Maintenance Manual

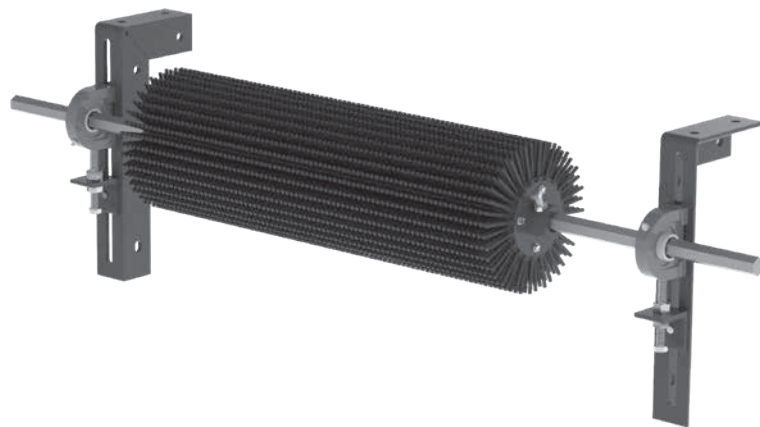

Chevron Cleaner

Purchase Date: _____

Purchased From: _____

Installation Date: _____

This information will be helpful for any future inquiries or questions about belt cleaner replacement parts, specifications or troubleshooting.

Table of Contents

Section 1 - Important Information	4
1.1 General Introduction	4
1.2 User Benefits	4
1.3 Service Option	4
Section 2 - Safety Considerations and Precautions	5
2.1 Stationary Conveyors.....	5
2.2 Operating Conveyors.....	5
Section 3 - Pre-Installation Checks and Options.....	6
3.1 Checklist	6
Section 4 - Installation Instructions.....	7
Section 5 - Pre-Operation Checklist and Testing.....	9
5.1 Pre-Op Checklist.....	9
5.2 Test Run the Conveyor	9
Section 6 - Maintenance.....	10
6.1 New Installation Inspection.....	10
6.2 Routine Visual Inspection.....	10
6.3 Routine Physical Inspection	10
6.4 Drum Replacement Instructions.....	11
6.5 Maintenance Log.....	13
6.6 Cleaner Maintenance Checklist.....	14
Section 7 - Troubleshooting	15
Section 8 - Specs and CAD Drawings.....	16
8.1 Specs and Guidelines	16
8.2 CAD Drawing.....	17
Section 9 - Replacement Parts	18
9.1 Replacement Parts and Poles	18
Section 10 - Other Flexco Conveyor Products	19

Section 1 - Important Information

1.1 General Introduction

We at Flexco are very pleased that you have selected a Chevron Cleaner for your conveyor system.

This manual will help you to understand the operation of this product and assist you in making it work up to its maximum efficiency over its lifetime of service.

It is essential for safe and efficient operation that the information and guidelines presented be properly understood and implemented. This manual will provide safety precautions, installation instructions, maintenance procedures and troubleshooting tips.

If, however, you have any questions or problems that are not covered, please contact your field representative or our Customer Service Department:

Customer Service: 612-8818-2000

Visit www.flexco.com for other Flexco locations and products.

Please read this manual thoroughly and pass it on to any others who will be directly responsible for installation, operation and maintenance of this product. While we have tried to make the installation and service tasks as easy and simple as possible, **it does however require correct installation and regular inspections and adjustments to maintain top working condition.**

1.2 User Benefits

Correct installation and regular maintenance will provide the following benefits for your operation:

- Reduced conveyor downtime
- Reduced man-hour labor
- Lower maintenance budget costs
- Increased service life for the belt cleaner and other conveyor components

1.3 Service Option

The Chevron Cleaner is designed to be easily installed and serviced by your on-site personnel. However, if you would prefer complete turn-key factory service, please contact your local Flexco Field Representative.

Section 2 - Safety Considerations and Precautions

Before installing and operating the Chevron Cleaner, it is important to review and understand the following safety information.

There are set-up, maintenance and operational activities involving both **stationary** and **operating** conveyors. Each case has a safety protocol.

2.1 Stationary Conveyors

The following activities are performed on stationary conveyors:

- Installation
- Drum replacement
- Repairs
- Tension adjustments
- Cleaning

DANGER

It is imperative that Lockout/Tagout (LOTO) regulations, be followed before undertaking the preceding activities. Failure to use LOTO exposes workers to uncontrolled behavior of the belt cleaner caused by movement of the conveyor belt. Severe injury or death can result.

Before working:

- Lockout/Tagout the conveyor power source
- Disengage any takeups
- Clear the conveyor belt or clamp securely in place

WARNING

Use Personal Protective Equipment (PPE):

- Safety eyewear
- Hardhats
- Safety footwear

Close quarters, springs and heavy components create a worksite that compromises a worker's eyes, feet and skull. PPE must be worn to control the foreseeable hazards associated with conveyor belt cleaners. Serious injuries can be avoided.

2.2 Operating Conveyors

There are two routine tasks that must be performed while the conveyor is running:

- Inspection of the cleaning performance
- Dynamic troubleshooting

DANGER

Every belt cleaner is an in-running nip hazard. Never touch or prod an operating cleaner. Cleaner hazards cause instantaneous amputation and entrapment.

WARNING

Belt cleaners can become projectile hazards. Stay as far from the cleaner as practical and use safety eyewear and headgear. Missiles can inflict serious injury.

WARNING

Never adjust anything on an operating cleaner. Unforseeable belt projections and tears can catch on cleaners and cause violent movements of the cleaner structure. Flailing hardware can cause serious injury or death.

Section 3 - Pre-Installation Checks and Options

3.1 Checklist

- Check that the cleaner size is correct for the beltline width
- Check the belt cleaner carton and make sure all the parts are included
- Review the “Tools Needed” list on the top of the installation instructions
- Check the conveyor site:
 - Will the cleaner be installed on a chute
 - Is the install on an open head pulley requiring mounting structure

Section 4 - Installation Instructions - Chevron Cleaner

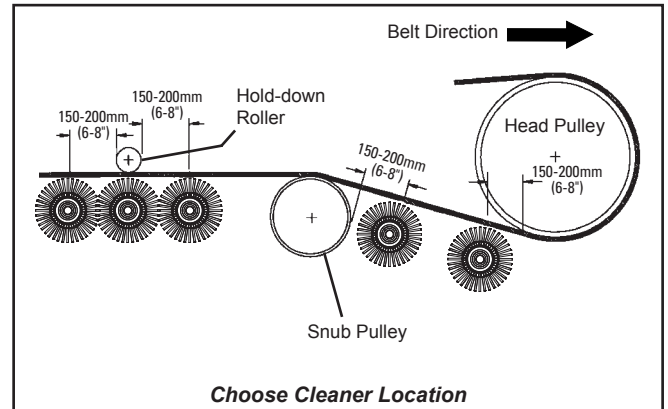
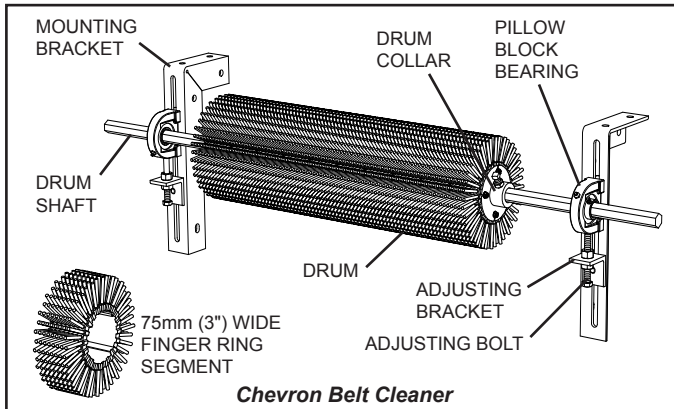

PHYSICALLY LOCK OUT AND TAG THE CONVEYOR AT THE POWER SOURCE BEFORE YOU BEGIN CLEANER INSTALLATION.

- Tools Needed:**
- Tape Measure
 - 16mm wrench
 - 19mm wrench
 - 17mm wrench
 - 4mm allen wrench

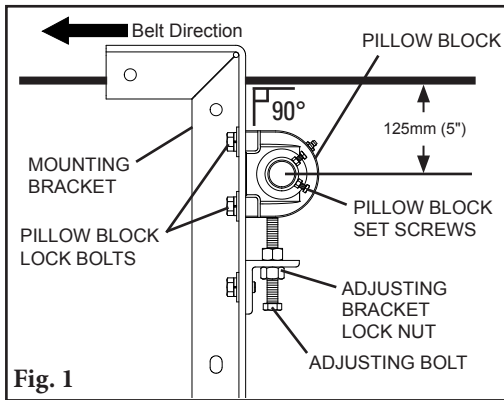

1. Install the Mounting Brackets. Position the mounting bracket to locate the cleaner shaft centreline 125mm below the beltline (Fig. 1). The shaft must be installed so the replacement drum **does not** touch the belt. Pillow block bearings may be raised or lowered by loosening the lock bolts and turning the adjusting bolt as needed. The pillow block bearings should have the set screws facing the outside of the conveyor. Position the brackets perpendicular to the belt.

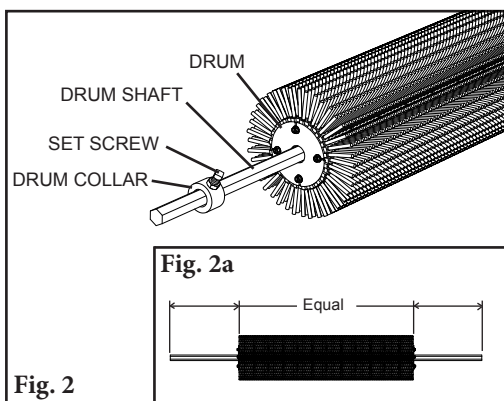

2. Assemble Drum Shaft to the Drum.

A. Insert the drum shaft into the drum until the drum is centred on the shaft (Fig. 2a).

B. Slide the drum collars on both ends of the shaft and tighten set screws.

Section 4 - Installation Instructions (cont.)

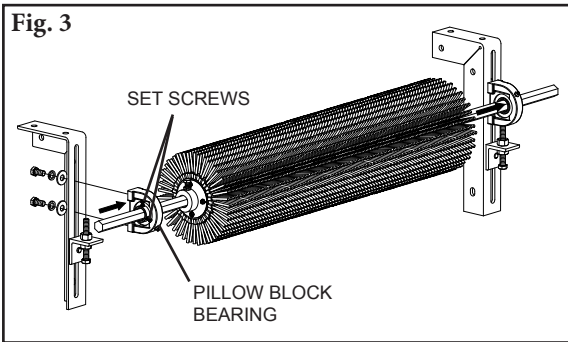

- 3. Install the Drum Shaft and Drum.** Remove the pillow block bearing from the mounting bracket on one side and loosen the set screws. Loosen the set screws on the remaining pillow block bearing. Slide the drum shaft into the pillow block bearing still on the mounting bracket. Slide the other pillow block bearing onto the shaft (set screws facing outward) and reassemble it to the mounting bracket (Fig. 3).

- 4. Centre the Drum.** Centre the drum on the belt. Tighten the pillow block set screws on both pillow block bearings.

- 5. Level the drum.** Turn the adjustment bolts to raise the drum so it just touches the belt across the entire width (Fig. 5).

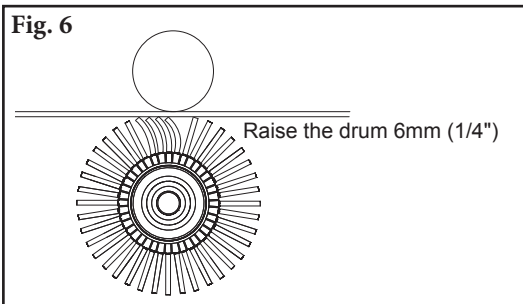
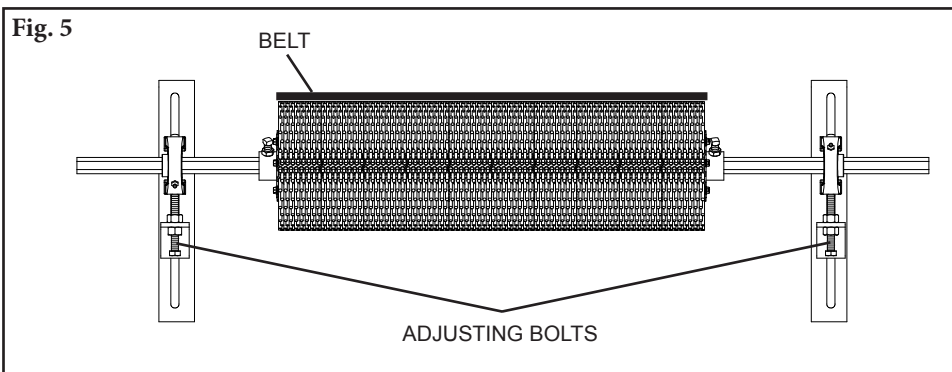

- 6. Set the cleaner tension.** Once the cleaner touches the belt, raise it up 6mm with the adjustment bolts (Fig. 6). Tighten the adjusting bolt lock nuts.

Note: Do not tension more than 6mm. Overtensioning will cause premature wear or damage to the rubber fingers.

Section 5 - Pre-Operation Checklist and Testing

5.1 Pre-Op Checklist

- Recheck that all fasteners are tightened properly
- Apply all supplied labels to the cleaner
- Check the drum location on the belt
- Be sure that all installation materials and tools have been removed from the belt and the conveyor area

5.2 Test Run the Conveyor

- Run the conveyor for at least 15 minutes and inspect the cleaning performance
- Check the drum and fingers for proper tensioning
- Make adjustments as necessary

NOTE: Observing the cleaner when it is running and performing properly will help to detect problems or when adjustments are needed later.

Section 6 - Maintenance

Flexco belt cleaners are designed to operate with minimum maintenance. However, to maintain superior performance some service is required. When the cleaner is installed a regular maintenance program should be set up. This program will ensure that the cleaner operates at optimal efficiency and problems can be identified and fixed before the cleaner stops working.

All safety procedures for inspection of equipment (stationary or operating) must be observed. The Chevron Cleaner operates at the discharge end of the conveyor and is in direct contact with the moving belt. Only visual observations can be made while the belt is running. Service tasks can be done only with the conveyor stopped and by observing the correct lockout/tagout procedures.

6.1 New Installation Inspection

After the new cleaner has run for a few days a visual inspection should be made to ensure the cleaner is performing properly. Make adjustments as needed.

6.2 Routine Visual Inspection (every 2-4 weeks)

A visual inspection of the cleaner and belt should look for:

- If belt looks clean or if there are areas that are dirty
- If cleaner is worn out and needs to be replaced
- If there is damage to the cleaner or other cleaner components
- If fugitive material is built up on cleaner or in the transfer area
- If there is cover damage to the belt
- If there is vibration or bouncing of the cleaner on the belt
- If a snub pulley is used, a check should be made for material buildup on the pulley
- Significant signs of carryback
- If any of the above conditions exist, a determination should be made on when the conveyor can be stopped for cleaner maintenance.

6.3 Routine Physical Inspection (every 6-8 weeks)

When the conveyor is not in operation and properly locked and tagged out, a physical inspection of the cleaner to perform the following tasks:

- Clean material buildup off of the cleaner and pole
- Closely inspect the cleaner for wear and any damage. Replace if needed.
- Ensure full cleaner to belt contact
- Inspect the cleaner pole for damage
- Inspect all fasteners for tightness and wear. Tighten or replace as needed.
- Replace any worn or damaged components
- Check the tension of the cleaner to the belt. Adjust the tension if necessary.
- When maintenance tasks are completed, test run the conveyor to ensure the cleaner is performing properly.

Section 6 - Maintenance

6.4 Drum/Ring Replacement Instructions

BEFORE YOU BEGIN:

Physically Lock Out And Tag The Conveyor At The Power Source.

- Tools Needed:**
- Tape Measure
 - 16mm wrench
 - 19mm wrench
 - 17mm wrench
 - 4mm allen wrench

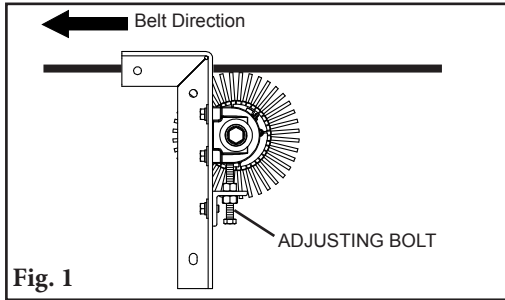

1. **Remove tension from drum to belt contact.** Lower the adjusting bolts to make room for the new drum (Fig.1).

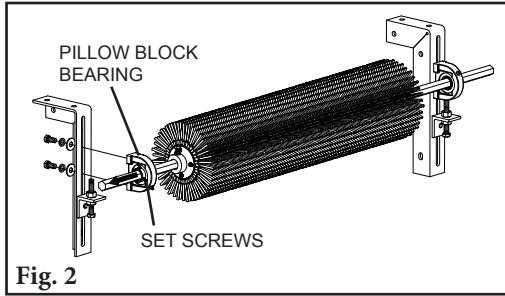

2. **Remove worn drum.** Loosen set screws on both ends. Then remove the pillow block bearing from the mounting bracket on one side. Slide the drum and shaft out of the second pillow block (Fig 2.)

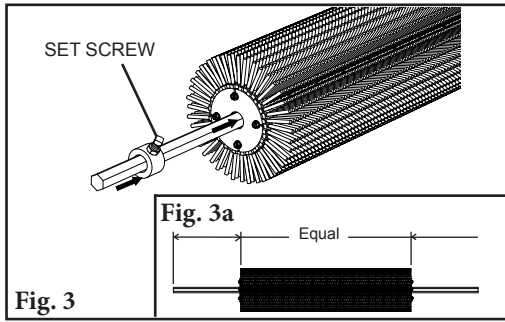

3a. **Replacing the whole drum.** Loosen the drum collar set screw and remove collar on one end (Fig. 3). Insert the drum shaft into the new drum until the drum is centred on the shaft (Fig. 3a). Replace the drum collar and tighten the set screw.

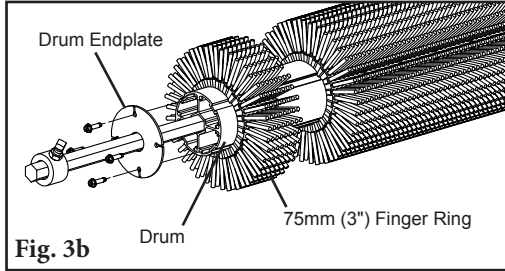

3b. **Replacing 75mm (3 inch) finger segments.** Remove drum endplate, then remove worn finger rings from drum. Clean drum and slide new 75mm (3 inch) rubber finger segments onto drum (Fig. 3b). Soapy water can be used to make this easier. Reinstall the endplate.

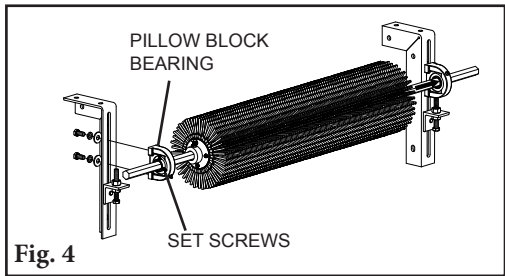

4. **Install the Drum Shaft and Drum.** Slide the drum shaft into the pillow block bearing still on the mounting bracket. Slide the other pillow block bearing onto the shaft (set screws facing outward) and reassemble it to the mounting bracket (Fig. 4).

Section 6 - Maintenance

6.4 Drum Replacement Instructions Cont.

5. **Centre the Drum.** Centre the drum on the belt. Tighten the pillow block set screws on both pillow block bearings.
6. **Level the drum.** Turn the adjustment bolts to raise the drum so it just touches the belt across the entire width (Fig. 5).

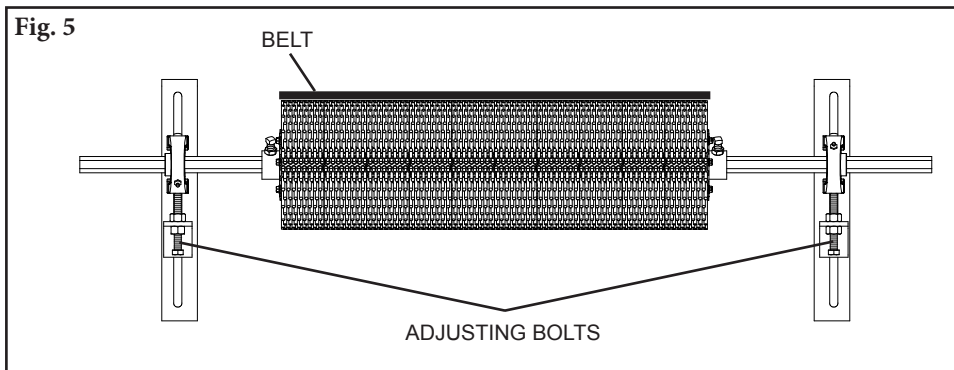

7. **Set the cleaner tension.** Once the cleaner touches the belt, raise it up 6mm with the adjustment bolts (Fig. 6). Tighten the adjusting bolt lock nuts.

Note: Do not tension more than 6mm (1/4"). Overtensioning will cause premature wear or damage to the rubber fingers.

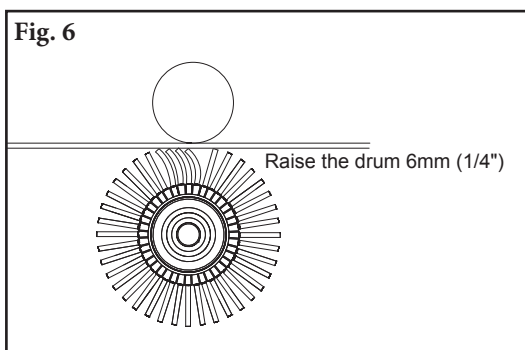

8. **Test run and inspect.** Run the belt and check that the Chevron runs smoothly and has an effective cleaning action.

Section 6 - Maintenance

6.5 Maintenance Log

Conveyor Name/No. _____

Date: _____ Work done by: _____ Service Quote #: _____

Activity: _____

Date: _____ Work done by: _____ Service Quote #: _____

Activity: _____

Date: _____ Work done by: _____ Service Quote #: _____

Activity: _____

Date: _____ Work done by: _____ Service Quote #: _____

Activity: _____

Date: _____ Work done by: _____ Service Quote #: _____

Activity: _____

Date: _____ Work done by: _____ Service Quote #: _____

Activity: _____

Date: _____ Work done by: _____ Service Quote #: _____

Activity: _____

Date: _____ Work done by: _____ Service Quote #: _____

Activity: _____



Section 6 - Maintenance

6.6 Cleaner Maintenance Checklist

Site: _____ Inspected by: _____ Date: _____

Belt Cleaner: _____ Serial Number: _____

Beltline Information:

Beltline Number: _____ Belt Condition: _____

Belt Width: 450mm 600mm 750mm 900mm 1050mm 1200mm 1350mm 1500mm 1800mm 2100mm
(18") (24") (30") (36") (42") (48") (54") (60") (72") (84")

Head Pulley Diameter (Belt & Lagging): _____ Belt Speed: _____ M/sec Belt Thickness: _____

Belt Splice: _____ Condition of Splice: _____ Number of Splices: _____ Skived Unskived

Material conveyed: _____

Days per week run: _____ Hours per day run: _____

Drum Life:

Date installed: _____ Date inspected: _____ Estimated life: _____

Is cleaner making complete contact with belt? Yes No

Drum condition: Good Not contacting belt Damaged

Was Cleaner Adjusted: Yes No

Shaft Condition: Good Bent Worn

Lagging: Side Lag Ceramic Rubber Other None

Condition of lagging: Good Bad Other _____

Cleaner's Overall Performance: (Rate the following 1 - 5, 1= very poor - 5 = very good)

Appearance: Comments: _____

Location: Comments: _____

Maintenance: Comments: _____

Performance: Comments: _____

Other comments _____

Section 7 - Troubleshooting

Problem	Possible Cause	Possible Solutions
Vibration	Cleaner secure bolts not set	Ensure all locking nuts are tight (Loctite)
	Cleaner not set up correctly	Ensure cleaner set up properly
	Belt tension too high	Ensure cleaner can conform to belt, or replace with alternate Flexco secondary cleaner
	Belt flap	Introduce hold-down roller to flatten belt
	Cleaner over-tensioned	Ensure cleaner is correctly tensioned
	Cleaner under-tensioned	Ensure cleaner is correctly tensioned
Material buildup on cleaner	Cleaner not set up correctly	Ensure cleaner set up properly
	Buildup on chute	Ensure cleaner is not located too close to back of chute, allowing buildup
	Cleaner being overburdened	Introduce Flexco precleaner
	Excessive sticky material	Frequently clean unit of buildup
Damaged belt cover	Cleaner over-tensioned	Ensure cleaner is correctly tensioned
	Cleaner fingers damage	Check fingers for wear, damage and chips, replace where necessary
	Material buildup in chute	Frequently clean unit of buildup
Cleaner not conforming to belt	Cleaner not set up correctly	Ensure cleaner set up properly
	Belt tension too high	Ensure cleaner can conform to belt, or replace with alternate Flexco secondary cleaner
	Belt flap	Introduce hold-down roller to flatten belt
	Cleaner cannot conform	Ensure cleaner can conform to belt, or replace with alternate Flexco secondary cleaner
Material passing cleaner	Cleaner not set up correctly	Ensure cleaner set up properly
	Cleaner tension too low	Ensure cleaner is correctly tensioned
	Cleaner fingers worn/damaged	Check fingers for wear, damage and chips, replace where necessary
	Cleaner being overburdened	Introduce Flexco precleaner
	Belt flap	Introduce hold-down roller to flatten belt
	Cleaner cannot conform	Ensure cleaner can conform to belt, or replace with alternate Flexco secondary cleaner
Damage to mechanical fastener	Incorrect cleaner selection	Change cleaner type to accommodate fastener style
	Belt not skived correctly	Spot and redo splice correctly, lowering the profile flush or below belt surface
Missing material in belt centre only	Cleaner shaft located too high	Ensure cleaner set up properly
	Cleaner fingers worn/damaged	Check fingers for wear, damage and chips, replace where necessary
Missing material on outer edges only	Cleaner shaft located too low	Ensure cleaner set up properly
	Cleaner fingers worn/damaged	Check fingers for wear, damage and chips, replace where necessary

Section 8 - Specs and CAD Drawings

8.1 Specs and Guidelines

Specifications

Belt Speed	2.5M/sec (Up to 500 fpm)
Vertical and Horizontal Clearance	250mm (10")
Temperature Range	-35°C to 82°C (-30°F to 180°F)
Maximum Chevron or Cleat Height	25mm (1")
Finger Length	50mm (2")
Rubber Durometer	45A
Overall Diameter	238mm (9-1/2")
Shaft Length	Belt Width plus 750mm (30")
Shaft Diameter	25mm (1")

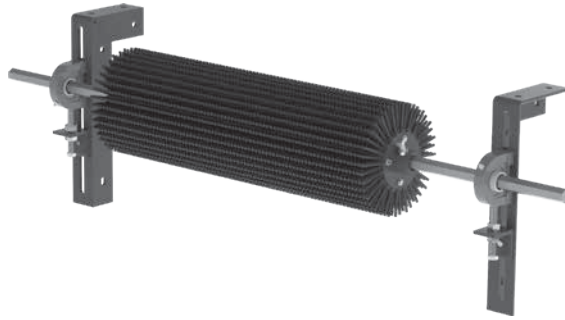

Product Notes:

- Free-rotating. Works only when the belt is running.
- Self-cleaning. Finger length, spacing and the rotary action allows carryback to fall free instead of clogging.
- Easy to install. Few parts and step-by-step instructions make the job simple.
- Long-wearing SBR rubber. Drum life ranges from 1 to 3 years depending upon the application conditions and the material being conveyed.
- Works on reversing belts.
- Finger rings can be replaced individually or all at once by replacing the drum.

Section 8 - Specs and CAD Drawings

8.2 CAD Drawing

SPECIFICATIONS		CHEVRON CLEANER	
BELT WIDTH (in)	DRUM WIDTH 'A' (in)	ORDER NUMBER	ITEM CODE
18	450	CBC18	76668
24	600	CBC24	76669
30	750	CBC30	76670
36	900	CBC36	76671
42	1050	CBC42	76672
48	1200	CBC48	76673
54	1350	CBC54	76674
60	1500	CBC60	76675
72	1800	CBC72	90762
84	2100	CBC84	90763

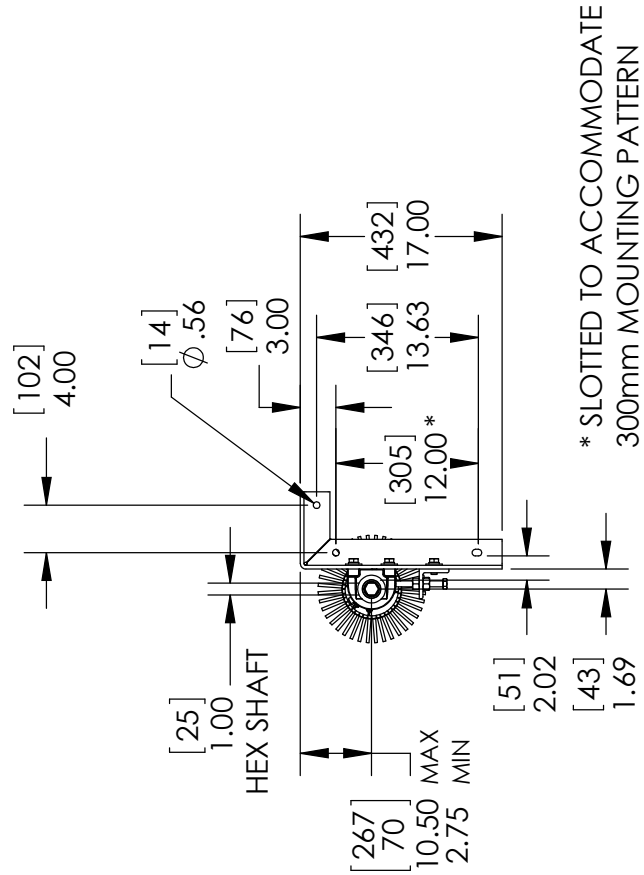
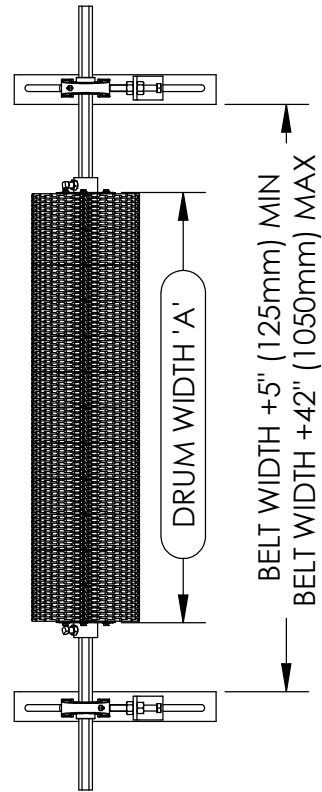

Section 9 - Replacement Parts

9.1 Replacement Parts List

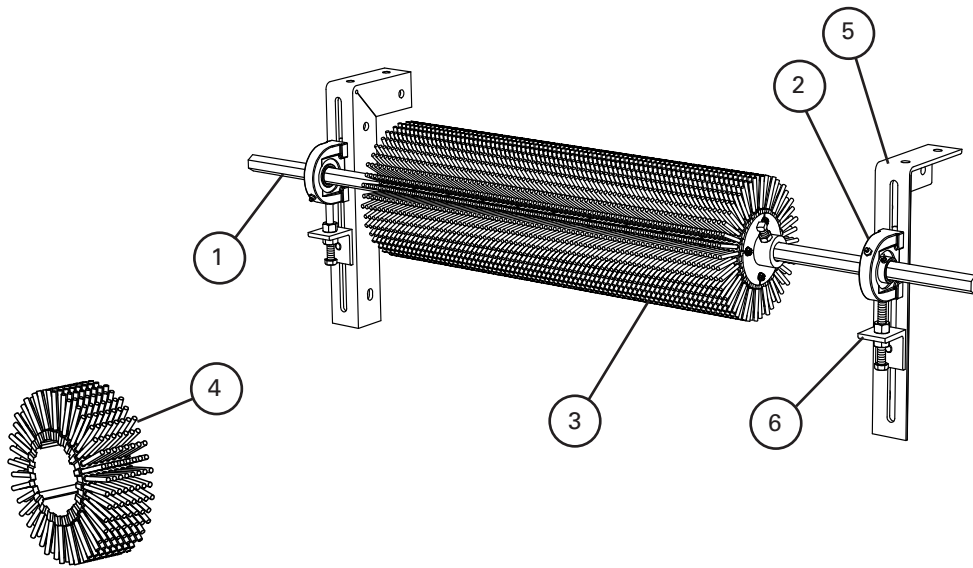

Replacement Parts

REF	DESCRIPTION	ORDERING NUMBER	ITEM CODE	WT. KG.
1	450mm (18") Drum Shaft	CBCS18	90537	6.8
	600mm (24") Drum Shaft	CBCS24	90538	7.7
	750mm (30") Drum Shaft	CBCS30	90539	8.6
	900mm (36") Drum Shaft	CBCS36	90540	9.4
	1050mm (42") Drum Shaft	CBCS42	90541	10.3
	1200mm (48") Drum Shaft	CBCS48	90542	11.2
	1350mm (54") Drum Shaft	CBCS54	90543	12.0
	1500mm (60") Drum Shaft	CBCS60	90544	12.8
	1800mm (72") Drum Shaft	CBCS72	90554	16.4
	2100mm (84") Drum Shaft	CBCS84	90555	18.0
2	Chevron Pillow Block*	CPB	76692	0.5
3	450mm (18") Repl Drum w/Fingers*	CRDF18	90631	11.3
	600mm (24") Repl Drum w/Fingers*	CRDF24	90632	14.1
	750mm (30") Repl Drum w/Fingers*	CRDF30	90633	17.2
	900mm (36") Repl Drum w/Fingers*	CRDF36	90634	20.4
	1050mm (42") Repl Drum w/Fingers*	CRDF42	90635	23.1
	1200mm (48") Repl Drum w/Fingers*	CRDF48	90636	26.3
	1350mm (54") Repl Drum w/Fingers*	CRDF54	90637	29.0
	1500mm (60") Repl Drum w/Fingers*	CRDF60	90638	32.2
	1800mm (72") Repl Drum w/Fingers*	CRDF72	90639	38.1
	2100mm (84") Repl Drum w/Fingers*	CRDF84	90640	44.0
4	75mm (3") Replacement Finger Ring Segment	CBC3R	90641	1.1
5	Mounting Bracket Kit (1 Right and 1 Left)	EZS2MBK	75666	5.9
6	Adjusting Bracket Kit* (1 ea.)	PAB	75513	0.7

*Hardware Included

Lead time: 1 working day

Shaded items are made to order.
Lead time: 3 working days

Section 10 - Other Flexco Conveyor Products

Flexco provides many conveyor products that help your conveyors to run more efficiently and safely. These components solve typical conveyor problems and improve productivity. Here is a quick overview on just a few of them:

MMP Primary Cleaner



- Extra cleaning power right on the head pulley
- A 250mm (10") TuffShear™ blade provides increased blade tension on the belt to peel off abrasive materials
- The unique Visual Tension Check™ ensures optimal blade tensioning and quick, accurate retensioning
- Easy to install and simple to service

DRX Impact Beds



- Adjusting troughing angles for easy installation and adjustability
- Long-wearing UHMW for sealing the load zone
- Offered in both Light & Medium duty designs to affordably fit your application

MHS Secondary Cleaner with Service Advantage Cartridge

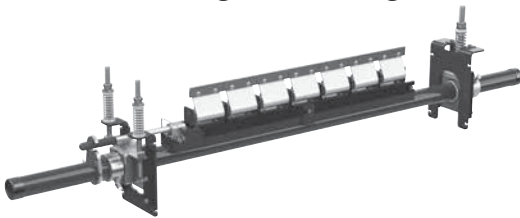

- An easy slide-out cartridge for service
- Cartridge design to speed up blade-change maintenance
- Patented PowerFlex™ Cushions for superior cleaning performance
- Compatible with Flexco mechanical splices

PT Max™ Belt Trainer



- Patented “pivot & tilt” design for superior training action
- Dual sensor rollers on each side to minimise belt damage
- Pivot point guaranteed not to seize or freeze up
- Available for topside and return side belts

Flexco Specialty Belt Cleaners



- “Limited space” cleaners for tight conveyor applications
- High Temp cleaners for severe, high heat applications
- Multiple cleaner styles in stainless steel for corrosive applications

Belt Ploughs

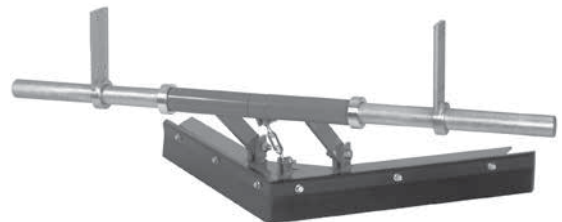

- A belt cleaner for the tail pulley
- Exclusive blade design quickly spirals debris off the belt
- Economical and easy to service
- Available in vee or diagonal models

The Flexco Vision

To become the leader in maximising
belt conveyor productivity for our customers worldwide
through superior service and innovation.

Flexco (Aust.) Pty. Ltd • 10 Solent Circuit • Baulkham Hills NSW 2153 • Australia
Tel: 612-8818-2000 • Fax: 612-8824-6333 • E-mail: salesau@flexco.com

Visit www.flexco.com for other Flexco locations and products.

©2018 Flexible Steel Lacing Company. 10/04/18. For reorder: X3165

