

U-Type[®] Secondary Belt Cleaner

Installation, Operation and Maintenance Manual

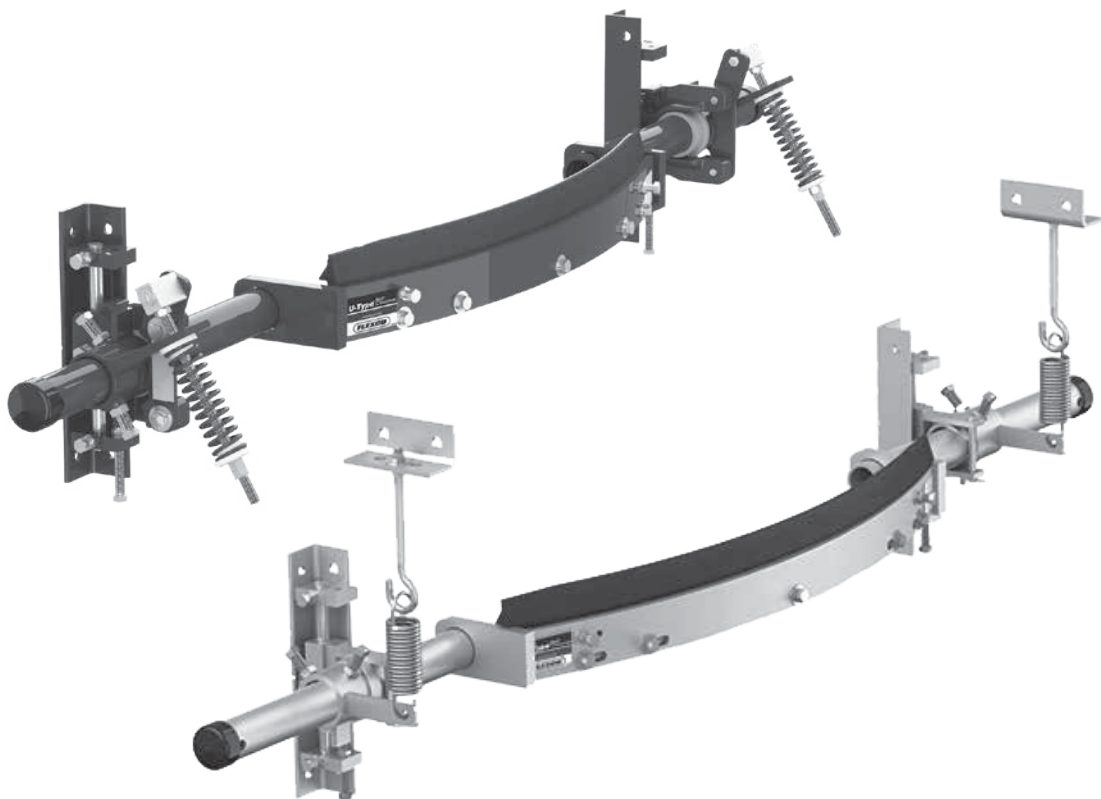

U-Type Secondary Cleaner

Serial Number:	_____
Purchase Date:	_____
Purchased From:	_____
Installation Date:	_____

Serial number information can be found on the Serial Number Label included in the Information Packet shipped in the cleaner carton.

This information will be helpful for any future inquiries or questions about belt cleaner replacement parts, specifications or troubleshooting.

Table of Contents

Section 1 - Important Information	2
1.1 General Introduction.....	2
1.2 User Benefits	2
1.3 Service Option	2
Section 2 - Safety Considerations and Precautions	3
2.1 Stationary Conveyors.....	3
2.2 Operating Conveyors.....	3
Section 3 - Pre-Installation Checks and Options.....	4
3.1 Checklist.....	4
3.2 Optional Installation Accessories.....	5
3.3 Correct Blade Installation and Tensioning	6
Section 4 - Installation Instructions.....	7
Section 5 - Pre-Operation Checklist and Testing.....	12
5.1 Pre-Op Checklist.....	12
5.2 Test Run the Conveyor	12
Section 6 - Maintenance.....	13
6.1 New Installation Inspection.....	13
6.2 Routine Visual Inspection.....	13
6.3 Routine Physical Inspection	13
6.4 Blade Replacement Instructions.....	14
6.5 Maintenance Log.....	16
6.6 Cleaner Maintenance Checklist.....	17
Section 7 - Troubleshooting	18
Section 8 - Specifications and CAD Drawing	19
8.1 Specs and Guidelines	19
8.2 CAD Drawing - Cleaners with UST Tensioners	20
8.3 CAD Drawing - Cleaners with J-Bolt Tensioners.....	21
Section 9 - Replacement Parts.....	22
9.1 Replacement Parts and Poles (Mild Steel)	23
9.2 Replacement Parts and Poles (Stainless Steel).....	24
9.3 Replacement Blades	25
Section 10 - Other Flexco Conveyor Products	26

Section 1 - Important Information

1.1 General Introduction

We at Flexco are very pleased that you have selected a U-Type® Secondary Cleaner for your conveyor system.

This manual will help you to understand the operation of this product and assist you in making it work up to its maximum efficiency over its lifetime of service.

It is essential for safe and efficient operation that the information and guidelines presented be properly understood and implemented. This manual will provide safety precautions, installation instructions, maintenance procedures and troubleshooting tips.

If, however, you have any questions or problems that are not covered, please contact your field representative or our Customer Service Department:

Customer Service: 1-800-541-8028

Visit www.flexco.com for other Flexco locations and products.

Please read this manual thoroughly and pass it on to any others who will be directly responsible for installation, operation and maintenance of this cleaner. While we have tried to make the installation and service tasks as easy and simple as possible, **it does however require correct installation and regular inspections and adjustments to maintain top working condition.**

1.2 User Benefits

Correct installation and regular maintenance will provide the following benefits for your operation:

- Reduced conveyor downtime
- Reduced man-hour labor
- Lower maintenance budget costs
- Increased service life for the belt cleaner and other conveyor components

1.3 Service Option

The U-Type Secondary Cleaner is designed to be easily installed and serviced by your on-site personnel. However, if you would prefer complete turn-key factory service, please contact your local Flexco Field Representative.

Section 2 - Safety Considerations and Precautions

Before installing and operating the U-Type® Secondary Cleaner, it is important to review and understand the following safety information.

There are set-up, maintenance and operational activities involving both **stationary** and **operating** conveyors. Each case has a safety protocol.

2.1 Stationary Conveyors

The following activities are performed on stationary conveyors:

- Installation
- Tension adjustments
- Blade replacement
- Cleaning
- Repairs

DANGER

It is imperative that OSHA/MSHA Lockout/Tagout (LOTO) regulations, 29 CFR 1910.147, be followed before undertaking the preceding activities. Failure to use LOTO exposes workers to uncontrolled behavior of the belt cleaner caused by movement of the conveyor belt. Severe injury or death can result.

Before working:

- Lockout/Tagout the conveyor power source
- Disengage any takeups
- Clear the conveyor belt or clamp securely in place

WARNING

Use Personal Protective Equipment (PPE):

- Safety eyewear
- Hardhats
- Safety footwear

Close quarters, springs and heavy components create a worksite that compromises a worker's eyes, feet and skull. PPE must be worn to control the foreseeable hazards associated with conveyor belt cleaners. Serious injuries can be avoided.

2.2 Operating Conveyors

There are two routine tasks that must be performed while the conveyor is running:

- Inspection of the cleaning performance
- Dynamic troubleshooting

DANGER

Every belt cleaner is an in-running nip hazard. Never touch or prod an operating cleaner. Cleaner hazards cause instantaneous amputation and entrapment.

WARNING

Belt cleaners can become projectile hazards. Stay as far from the cleaner as practical and use safety eyewear and headgear. Missiles can inflict serious injury.

WARNING

Never adjust anything on an operating cleaner. Unforeseeable belt projections and tears can catch on cleaners and cause violent movements of the cleaner structure. Flailing hardware can cause serious injury or death.

Section 3 - Pre-Installation Checks and Options

3.1 Checklist

- Check that the cleaner size is correct for the beltline width
- Check the belt cleaner carton and make sure all the parts are included
- Review the “Tools Needed” list on the top of the installation instructions
- Check the conveyor site:
 - Will the cleaner be installed on a chute
 - Is the install on an open head pulley requiring mounting structure (see 3.2 - Optional Installation Accessories)

3.2 Optional Installation Accessories

Versatile, adjustable brackets that can be mounted on the conveyor structure so the U-Type cleaner can be quickly and easily bolted into place. Pole extenders are also available for wide, non-standard conveyor structures.

75666
Mounting Bracket Kit
 (includes 1 left and 1 right bracket)

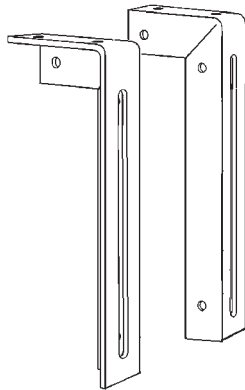

76024
Pole Extender Kit
 (includes 2 pole extenders)
 • For cleaner sizes 72" (1800mm) and larger
 • Provides 30" (750mm) of extended pole length

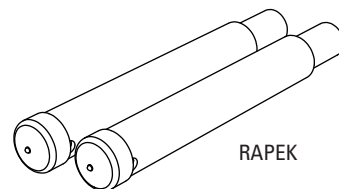
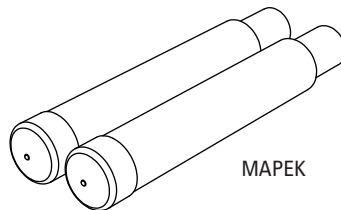

Optional Installation Accessories

DESCRIPTION	ORDERING NUMBER	ITEM CODE	WT. LBS.
Mounting Bracket Kit	EZS2MBK	75666	13.0
2-3/8" Pole Extender Kit	RAPEK	77423	18.0
2-7/8" Pole Extender Kit	MAPEK	76024	21.9

Section 3 - Pre-Installation Checks and Options

3.3 Correct Blade Installation and Tensioning

For optimal cleaning efficiency and long wear life, the U-Type® blade must be located and tensioned correctly on the belt. If the cleaner pole is in the wrong location the performance of the new blade may be adversely affected. See “Possible Problems” below. For tensioning, please follow these instructions.

Correct Pole Location:

When the blade contacts the belt (before tensioning) there should be blade-to-belt contact across the entire blade (Fig. 1). If contact is more in the center with a gap on the outer edges, the pole will need to be raised until full contact is achieved (Fig. 2). If contact is more on the outer edges with a gap in the center, the pole will need to be lowered until full contact is achieved (Fig. 3).

Possible Problems:

- Pole location too low - The initial cleaning will be concentrated in the center of the belt, failing to clean the outer edges efficiently.
- Pole location too high - The initial cleaning will be concentrated to the outer edges of the belt, failing to efficiently clean the center of the belt.
- Tension too low - Without the optimal tension, the cleaning efficiency is reduced and chatter or bouncing of the blade can occur.
- Tension too high - Although the cleaning may appear efficient, accelerated blade wear may occur; and in some cases less efficiency on the outer edges of the belt, which could result in increased belt wear.

Correct Tensioning:

Correct tension is determined and set by blade width. Check the information provided with the tensioner being used or consult the installation instructions.

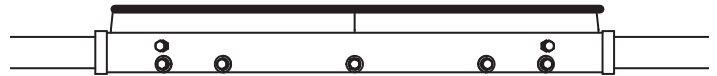

Fig. 1

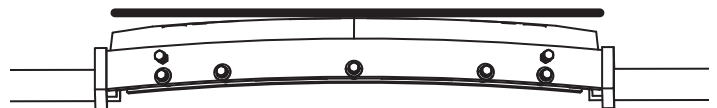

Fig. 2

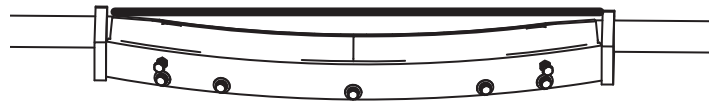
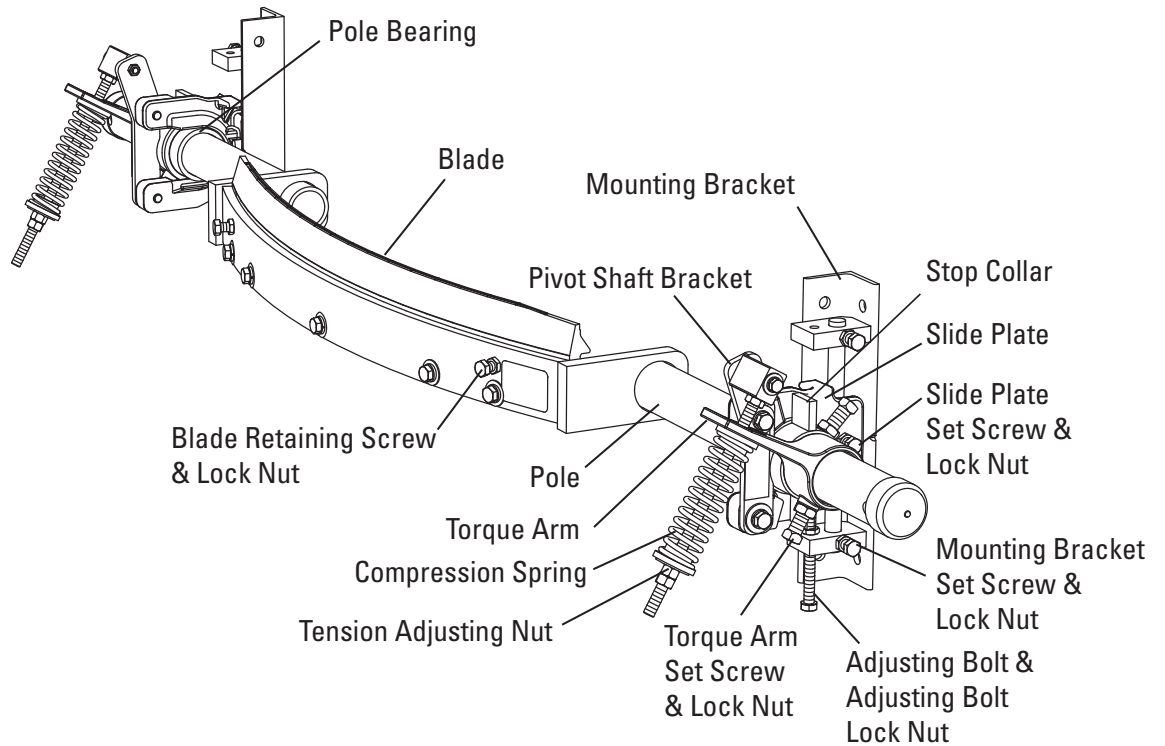

Fig. 3

Section 4 - Installation Instructions

4.1 U-Type® Secondary Cleaner



U-Type with UST Tensioner Parts List

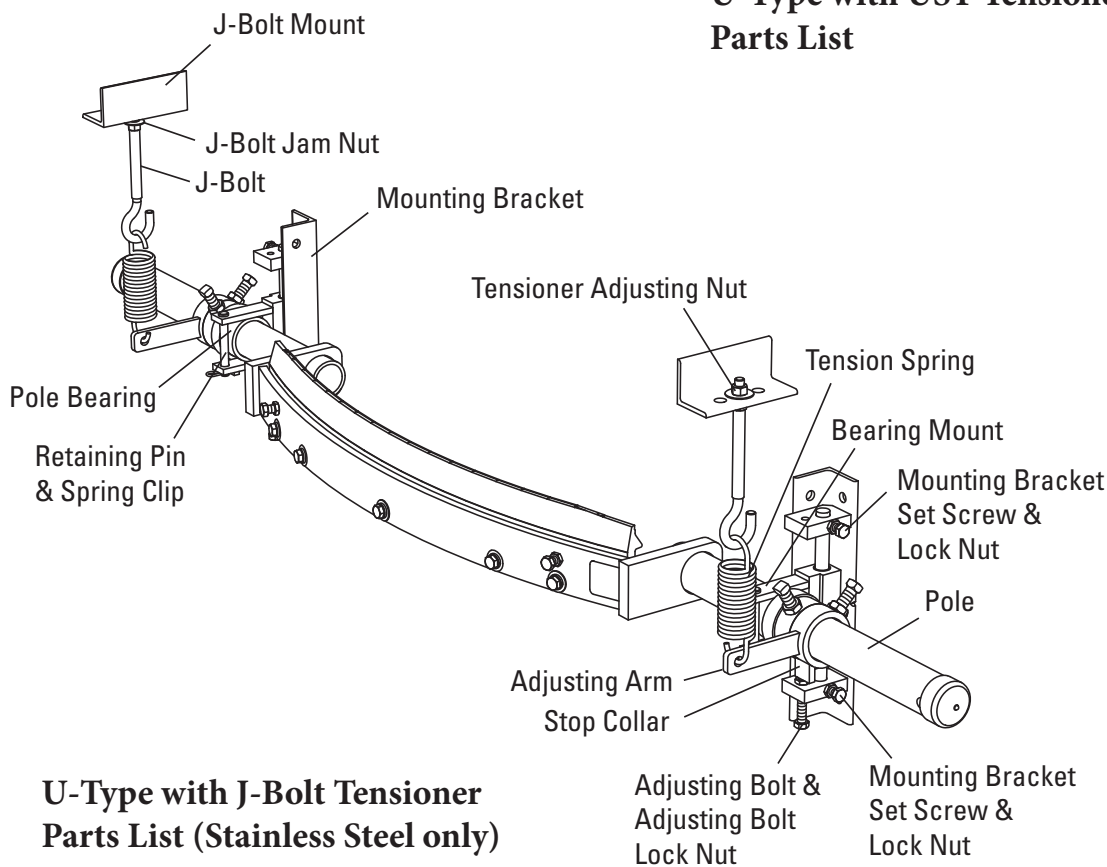

U-Type with J-Bolt Tensioner Parts List (Stainless Steel only)

Section 4 - Installation Instructions

4.1 U-Type® Secondary Cleaner

Physically lock out and tag the conveyor at the power source before you begin cleaner installation.

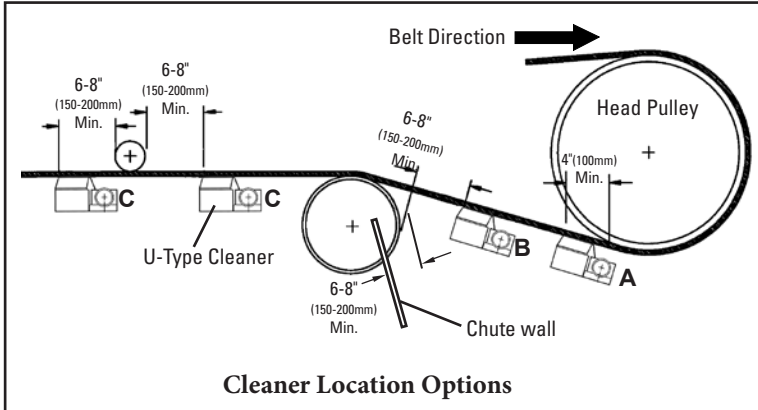

- Tools Needed:**
- Tape measure
 - 3/4" (19mm) wrench
 - Ratchet with 3/4" (19mm) socket
 - Screwdriver
 - (2) 6" C-clamps (optional for locating mounting brackets)
 - Level (optional for locating belt height)
 - Permanent marker
 - Cutting torch and/or welder
 - Square (for setting blade parallel to belt)

Before You Begin:

- Double-check the blade type needed for your application:
 F-Blade - for mechanically spliced belts.
 C-Blade - for Flexco Solid Plate mechanically spliced and vulcanized belts.
- For chute mounting it is necessary to cut an access hole. See access hole dimensions at right.
- Follow all safety precautions when using a cutting torch.
- If welding, protect all fastener threads from weld spatter.
- For cleaner clearance requirements see chart at right.

Cleaner Clearance Requirements

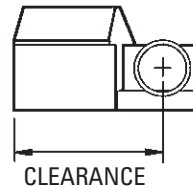

U Cleaner Size		Clearance	
in.	mm	in.	mm
18"	450	6	155
24"	600	7	180
30"	750	8	205
36"	900	8	205
42"	1050	9 1/4	235
48"	1200	10 1/2	270
54"	1350	10 3/4	275
60"	1500	10 3/4	275
72"	1800	10 3/4	275
84"	2100	10 3/4	275
96"	2400	10 3/4	275

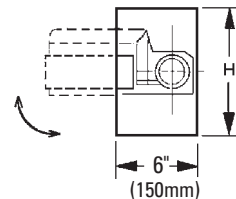
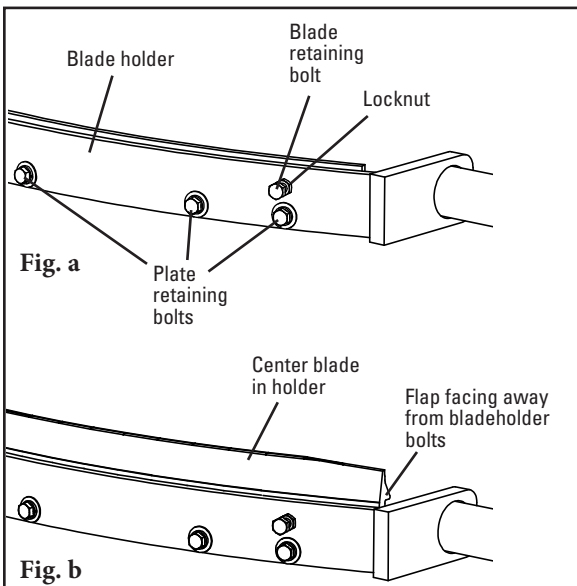

Chute Mounting Access Hole Dimensions

Belt Width	H Dimension
18" - 42" (450-1050mm)	8" (200mm)
48" - 96" (1200-2400mm)	10" (250mm)

Install the blade in the pole:

- Loosen both locknuts on the blade retaining bolts. Turn blade retaining bolts out 8 turns (Fig. a).
- Loosen (but do not remove) all plate retaining bolts (Fig. b).
- Install the new blade as shown in Fig. b. The flap on the blade should face away from bladeholder screws.
- Center the blade in the holder.
- Tighten all plate retaining screws.
- Tighten blade retaining screws 8 turns and tighten the blade retaining screw locknuts.

Section 4 - Installation Instructions

4.1 U-Type® Secondary Cleaner

1. Choose conveyor location where cleaner will be installed.

The U-Type may be positioned at any spot from where belt leaves head pulley on down the conveyor line (see positions A to B). If a chute area is too small due to a snub pulley, it may be necessary to mount cleaner behind chute (see position C). In chute applications a minimum of 6"-8" (150-200mm) is required between cleaner and chute wall to prevent clogging of material.

NOTE: For U-Type cleaners using UST Tensioners, proceed to Steps 2U - 7U.

For U-Types using J-Bolt Tensioners, skip ahead to Steps 2J - 8J on Page 10.

UST Tensioner Instructions

2U. Install mounting brackets.

- Using a level, lightly raise return side belt (take out cupping or sagging on edges) to find belt's true parallel path to the structure; and mark reference point #1 on structure. Measure down 3" (75mm) from reference point #1 and mark reference point #2 (Fig. 2Ua). Make sure brackets are the same distance away from head pulley or a reference point on both sides of the structure. If there is no structure to mount to, install mounting bracket first.
- Position mounting brackets so centerline marks on brackets are in line with reference points #2 on the structure (Fig. 2Ub).
- Clamp or weld into position.

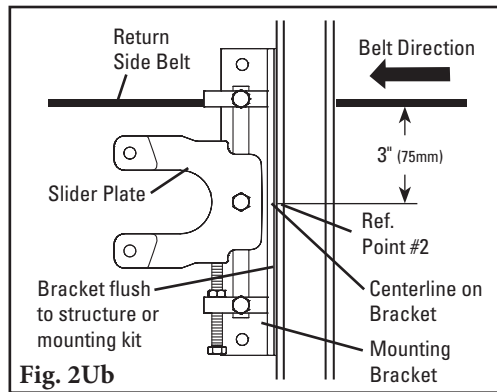
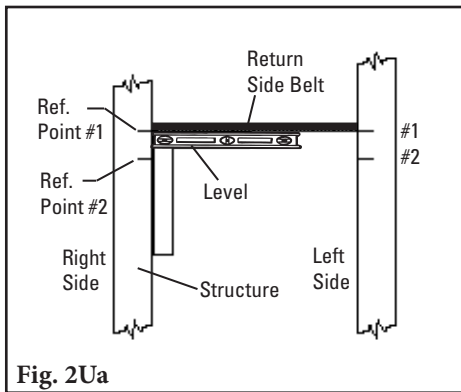

3U. Install the cleaner pole into the slider plates.

- Set pole ends into slider plate on both sides (Fig. 3Ua).
- Slide pole bearings onto both ends of the pole with flange facing away from the belt (Fig. 3Ub).
- Slide stop collar onto both ends of the pole (Fig. 3Ub). Do not tighten at this time.
- Slide torque arms onto both ends of pole and attach both pivot shaft brackets to slider plates (Fig. 3Ub). Blade and torque arm must face either in the direction of belt travel (Fig. 3Uc), or if clearance is an issue, switch to rotated tensioner configuration and assemble as shown (Fig. 3Ud).
- Move slider plate to bottom of bracket to allow blade to rotate up into position in the next steps.

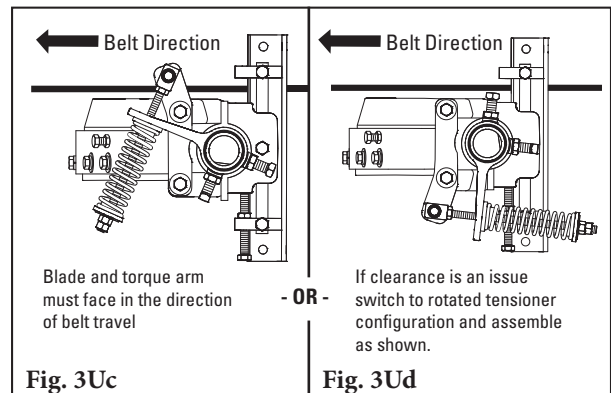
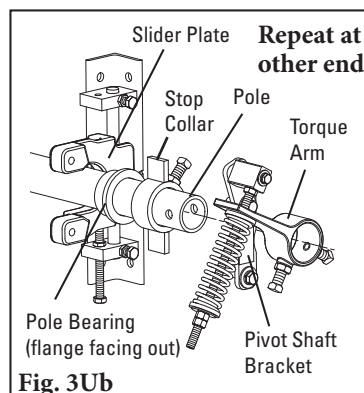
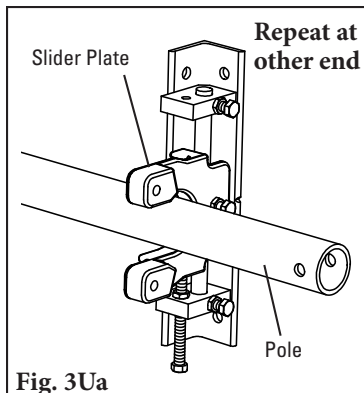

Section 4 - Installation Instructions

4.1 U-Type® Secondary Cleaner with UST Tensioner (cont.)

4U. Tighten torque arm set screws.

- Spring tension nuts should be moved near the end of the threaded rod. Insert a screwdriver or small rod through holes on end of cleaner pole. Pushing on screwdriver or rod, rotate cleaner blade into a position with pole parallel to belt (Fig. 4Ua). Blade should not be touching belt at this time. The gap between the torque arm and pivot block should be approximately 2".
- Center the blade to the belt and make sure torque arm, stop collar, bearing and slide plate are tight together on both sides. Then tighten stop collar set screw and lock nut with stop collar touching top of bearing mount stop to hold blade parallel to belt, and remove screwdriver or rod.
- Push torque arm down to contact the spring and tighten the torque arm set screws and lock nuts on both sides of the cleaner (Fig. 4Ub).

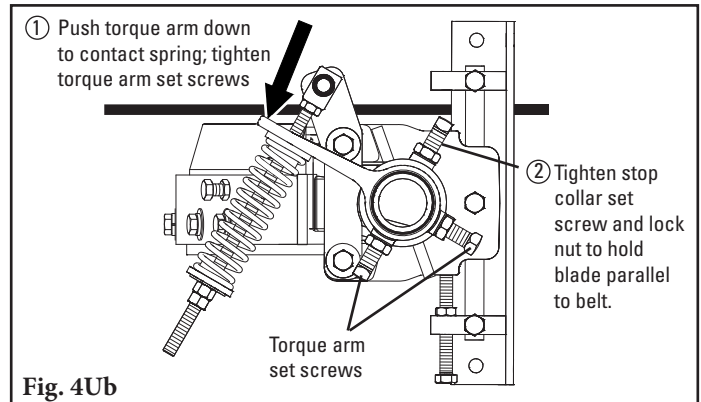
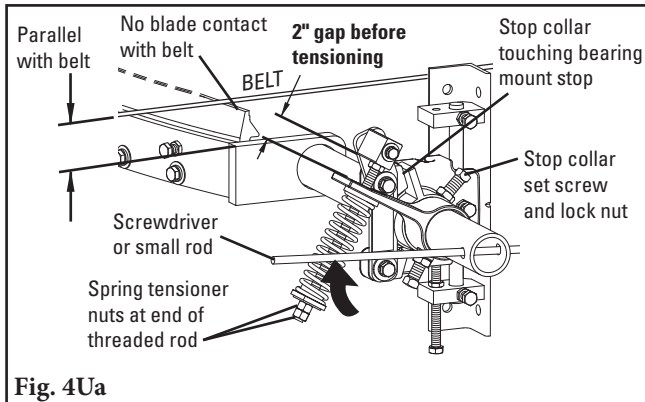

5U. Adjust the blade to the belt.

- Loosen slide plate set screws and lock nuts. Adjust by turning adjusting bolts either up or down (Fig. 5U).
- Adjust blade either up or down until both blade ends and the center make full contact with belt. If possible, adjust both sides of the cleaner up to the belt at the same time for even blade contact across belt (reduces chance of overtensioning on one side).

IMPORTANT: In some cases, due to irregular belt wear or cupping, it may be necessary to make final adjustments independently on both sides.

- Tighten lock nuts on adjusting bolts to secure blade in correct position. Also tighten slide plate set screws and lock nuts.

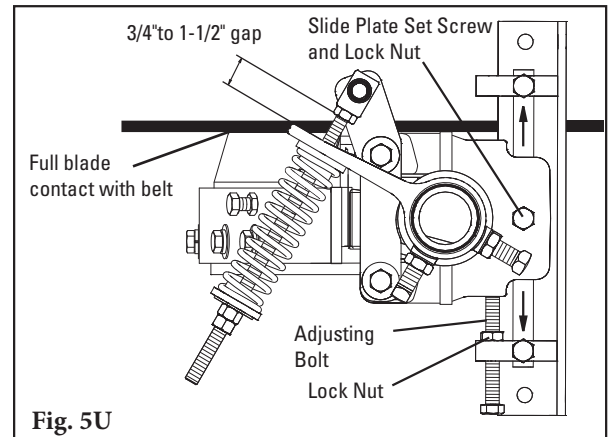

Spring Length Chart (for Cleaners with UST Tensioners)							
Blade Width	Purple Spring		Silver Spring		White Spring		
	in.	mm	in.	mm	in.	mm	
18	450	6 1/8	154	6 3/8	160	6 3/8	162
24	600	5 7/8	148	6 1/4	148	6 1/4	160
30	750	5 1/2	140	6 1/8	156	6 1/4	158
36	900	5 3/8	136	6	152	6 1/8	156
42	1050	5	128	5 7/8	150	6 1/8	154
48	1200	N/A	N/A	5 3/4	146	6	152
54	1350	N/A	N/A	5 5/8	142	5 7/8	150
60	1500	N/A	N/A	5 1/2	140	5 7/8	150
72	1800	N/A	N/A	N/A	N/A	5 1/2	140
84	2100	N/A	N/A	N/A	N/A	5 3/8	136
96	2400	N/A	N/A	N/A	N/A	5 1/4	132

6U. Set the blade tension.

- Set spring length to determined length (Fig. 6U). Tighten spring tension nuts on threaded rod. **IMPORTANT:** Always be sure there is uniform contact between blade and belt.
- If blade is not in full contact with belt at edges and center, either raise or lower pole position of cleaner and reapply tension.
- Please note, when fully tensioned there should be approximately 3/4" to 1-1/2" of space between the torque arm and pivot block (Fig. 5U).

Section 4 - Installation Instructions

4.1 U-Type® Secondary Cleaner with UST Tensioner (cont.)

7U. Set the blade travel stop.

Set both stop collars to a clearance of 1/4" (6mm) between stop collar and bottom bearing mount stop for UC cleaners, or 1/2" (13mm) for UF cleaners (Fig. 7U). This is to prevent blade from moving into belt. Tighten set screws and lock nuts.

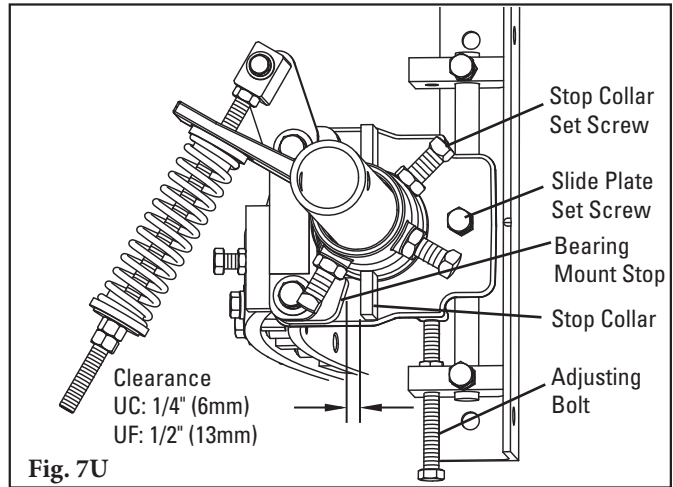

4.2 U-Type SS J-Bolt Cleaner

J-Bolt Tensioner Instructions - For Stainless Steel Cleaners

2J. Install the mounting brackets onto the structure.

- Using a square, lightly raise return side belt (take out cupping or sagging on edges) to find belt's true parallel path to the structure; and mark reference point #1 on the structure on both sides of the conveyor. Measure down 3-3/8" (84mm) from reference point #1 on both sides and mark reference point #2 (Fig. 2Ja).
- Position the mounting brackets so the centerline marks on the brackets are in line with reference points #2 on the structure (Fig. 2Jb).
- Clamp or weld into position.

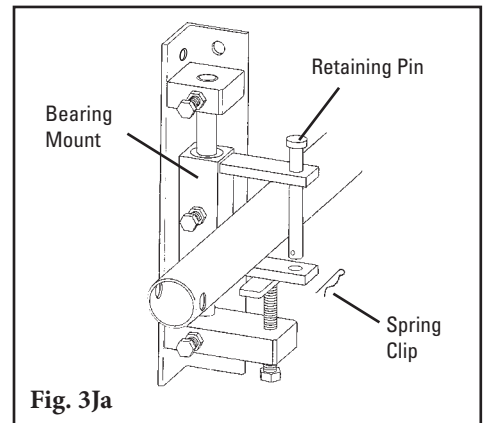
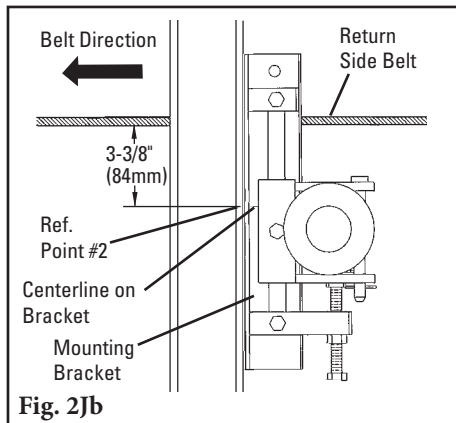
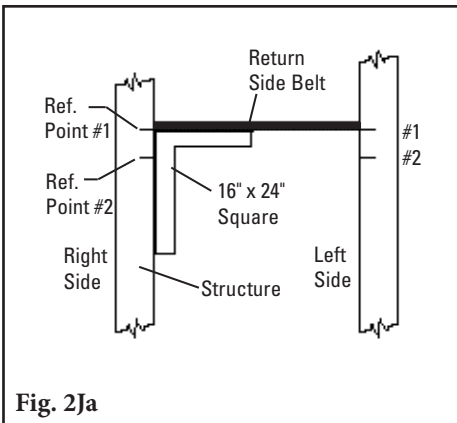

3J. Install cleaner pole into bearing mounts in both mounting brackets.

- Remove nylon bearings from both bearing mounts. Remove spring clip and pull retaining pin out of one bearing mount. Slide cleaner pole into bearing mount on the opposite side and then position it into bearing mount where retaining pin was removed. Reinsert retaining pin and lock into place with spring clip (Fig. 3Ja).
- Slide a nylon bearing onto each pole end with flanged end facing away from belt. Nylon bearing will fit snugly into bearing mount (Fig. 3Jb).
- Position the pole so that blade is centered to belt. With blade centered, draw a line around pole at nylon bearing. This line can be used as a reference point to ensure the pole/blade remains centered to belt while other steps are completed.

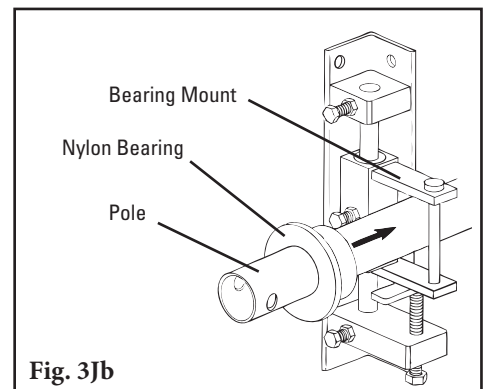

Section 4 - Installation Instructions

4.2 U-Type® Stainless Steel J-Bolt Cleaner (cont.)

4J. Install the stop collars.

- Slide one stop collar onto the most convenient pole end (Fig. 4Ja).
- Insert a screwdriver or small rod into hole on end of cleaner pole. Pushing on the rod, move blade into a position parallel to belt (Fig. 4Jb). Blade should not be touching belt at this time.
- Tighten stop collar set screw and lock nut to hold blade parallel to belt and remove screwdriver or rod.
- Install second stop collar on other pole end. Do not tighten set screw and lock nut at this time.

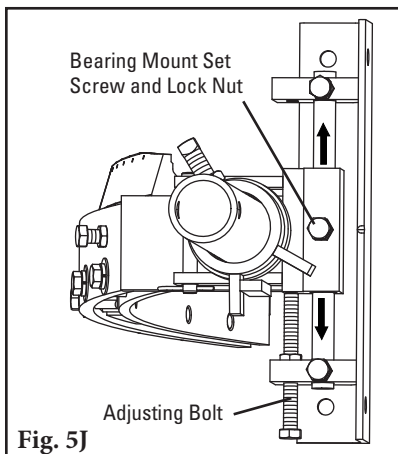
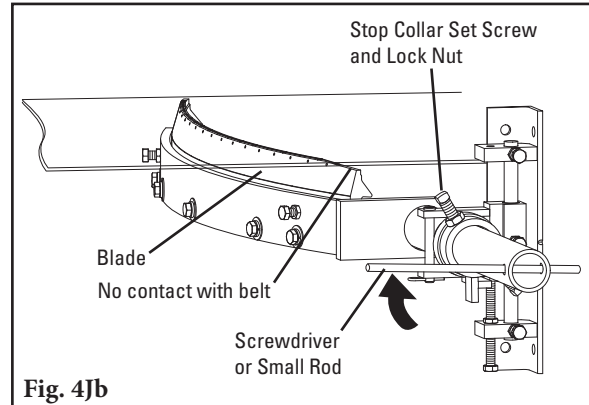
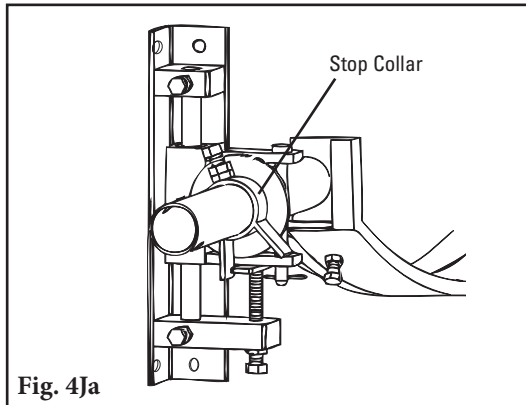

5J. Adjust blade to belt.

- Loosen bearing mount set screws and lock nuts. Adjustments will be made by turning adjusting bolts either up or down (Fig. 5J).
- Adjust blade either up or down until both blade ends and the center make full contact with belt.
IMPORTANT: In some cases, due to irregular belt wear or cupping, it may be necessary to make final adjustments independently on both sides.
- Tighten lock nuts on adjusting bolts to secure blade in correct position. Also tighten bearing mount set screws and lock nuts.

Section 4 - Installation Instructions

4.2 U-Type® SS J-Bolt Cleaner (cont.)

6J. Mount the tensioning system.

- Slide one adjusting arm onto pole end with stop collar that was not tightened (Fig. 6Ja).
- Assemble tension spring and J-bolt mount to adjusting arm. Locate position for J-bolt mount (Fig. 6Jb).
IMPORTANT: Allow at least 2" (50mm) of upward movement for J-bolt end for future adjustment.
- The J-bolt mount can be mounted in any position (360 degrees) around pole. The only requirement is that J-bolt and spring remain perpendicular to adjusting arm (Fig. 6Jc).
- Weld or bolt J-bolt mount into position.
- Tighten adjusting arm set screw and lock nut to secure position on pole.
- Adjust J-bolt to apply light tension on tension spring.

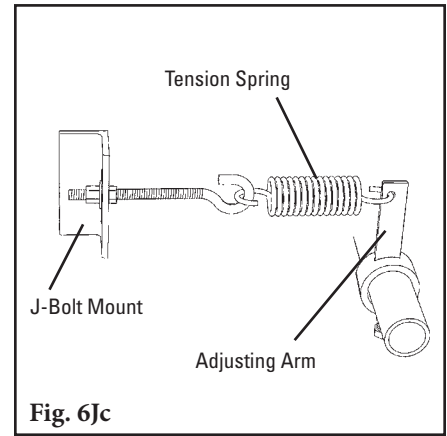
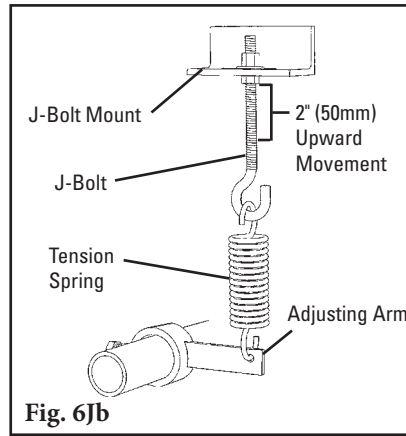
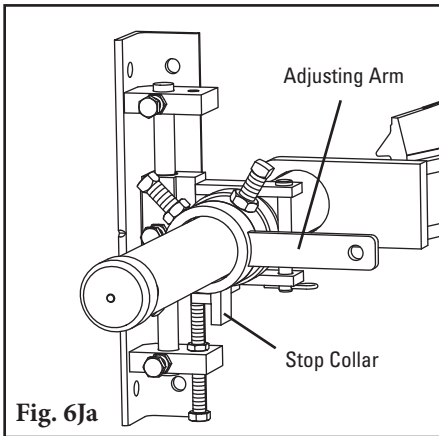

7J. Set up stop collar and assemble opposite tensioning system.

- Loosen stop collar (Fig. 7J).
- Slide the second adjusting arm on pole end; assemble and mount tensioning system.

8J. Set the spring tension.

- Loosen J-bolt jam nuts and turn tensioner adjusting nuts until both springs have a clearance of about .030" between all coils (use Spring Tension Gauge included in installation instruction packet.) (Fig. 8J).
IMPORTANT: Always be sure there is uniform contact between blade and belt.
- If blade is not in full contact with belt at edges and center, either raise or lower pole position of cleaner and reapply tension.

9J. Set the blade travel stop.

Set both stop collars to a clearance of 1/4" (6mm) for UC cleaners, or 1/2" (13mm) for UF cleaners, from bearing mount stops (Fig. 9J). This is to prevent blade from moving into belt. Tighten set screws and lock nuts.

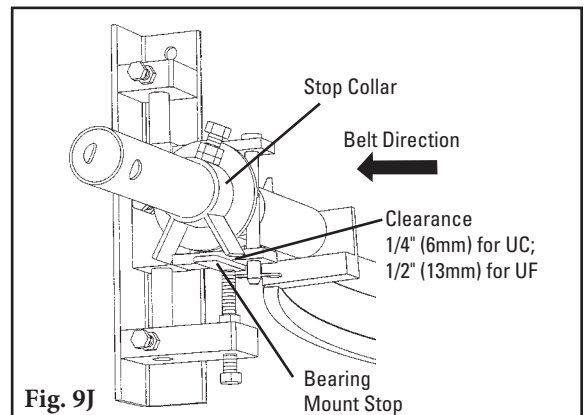
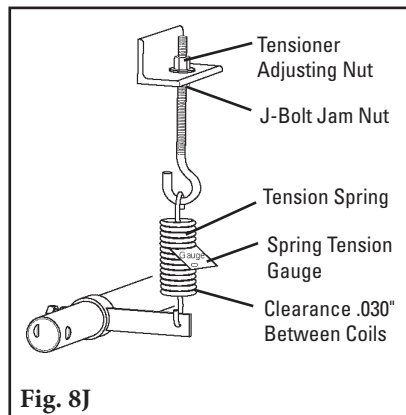
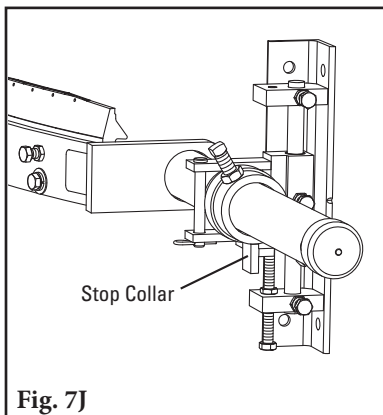

Section 5 - Pre-Operation Checklist and Testing

5.1 Pre-Op Checklist

- Recheck that all fasteners are tightened properly
- Add pole caps
- Apply all supplied labels to the cleaner
- Check the blade location on the belt
- Be sure that all installation materials and tools have been removed from the belt and the conveyor area

5.2 Test Run the Conveyor

- Run the conveyor for at least 15 minutes and inspect the cleaning performance
- Check the tensioner spring for recommended length (proper tensioning)
- Make adjustments as necessary

NOTE: Observing the cleaner when it is running and performing properly will help to detect problems or when adjustments are needed later.

Section 6 - Maintenance

Flexco belt cleaners are designed to operate with minimum maintenance. However, to maintain superior performance some service is required. When the cleaner is installed a regular maintenance program should be set up. This program will ensure that the cleaner operates at optimal efficiency and problems can be identified and fixed before the cleaner stops working.

All safety procedures for inspection of equipment (stationary or operating) must be observed. The U-Type Belt Cleaner operates at the discharge end of the conveyor and is in direct contact with the moving belt. Only visual observations can be made while the belt is running. Service tasks can be done only with the conveyor stopped and by observing the correct lockout/tagout procedures.

6.1 New Installation Inspection

After the new cleaner has run for a few days a visual inspection should be made to ensure the cleaner is performing properly. Make adjustments as needed.

6.2 Routine Visual Inspection (every 2-4 weeks)

A visual inspection of the cleaner and belt should look for:

- If spring length is the correct length for optimal tensioning
- If spring gap is correct for optimal tensioning (for J-Bolt tensioners)
- If belt looks clean or if there are areas that are dirty
- If blade is worn out and needs to be replaced
- If there is damage to the blade or other cleaner components
- If fugitive material is built up on cleaner or in the transfer area
- If there is cover damage to the belt
- If there is vibration or bouncing of the cleaner on the belt
- If a snub pulley is used, a check should be made for material buildup on the pulley
- Significant signs of carryback

If any of the above conditions exist, a determination should be made on when the conveyor can be stopped for cleaner maintenance.

6.3 Routine Physical Inspection (every 6-8 weeks)

When the conveyor is not in operation and properly locked and tagged out, a physical inspection of the cleaner to perform the following tasks:

- Clean material buildup off of the cleaner blade and pole
- Closely inspect the blade for wear and any damage. Replace if needed.
- Ensure full blade to belt contact
- Inspect the cleaner pole for damage
- Inspect all fasteners for tightness and wear. Tighten or replace as needed.
- Replace any worn or damaged components
- Check the tension of the cleaner blade to the belt. Adjust the tension if necessary using the chart on the cleaner or the one on Page 16. For J-bolt Tensioners, use the spring tension gauge to set a .030" (.7mm) gap between spring coils.
- When maintenance tasks are completed, test run the conveyor to ensure the cleaner is performing properly

Section 6 - Maintenance

6.4 Blade Replacement Instructions

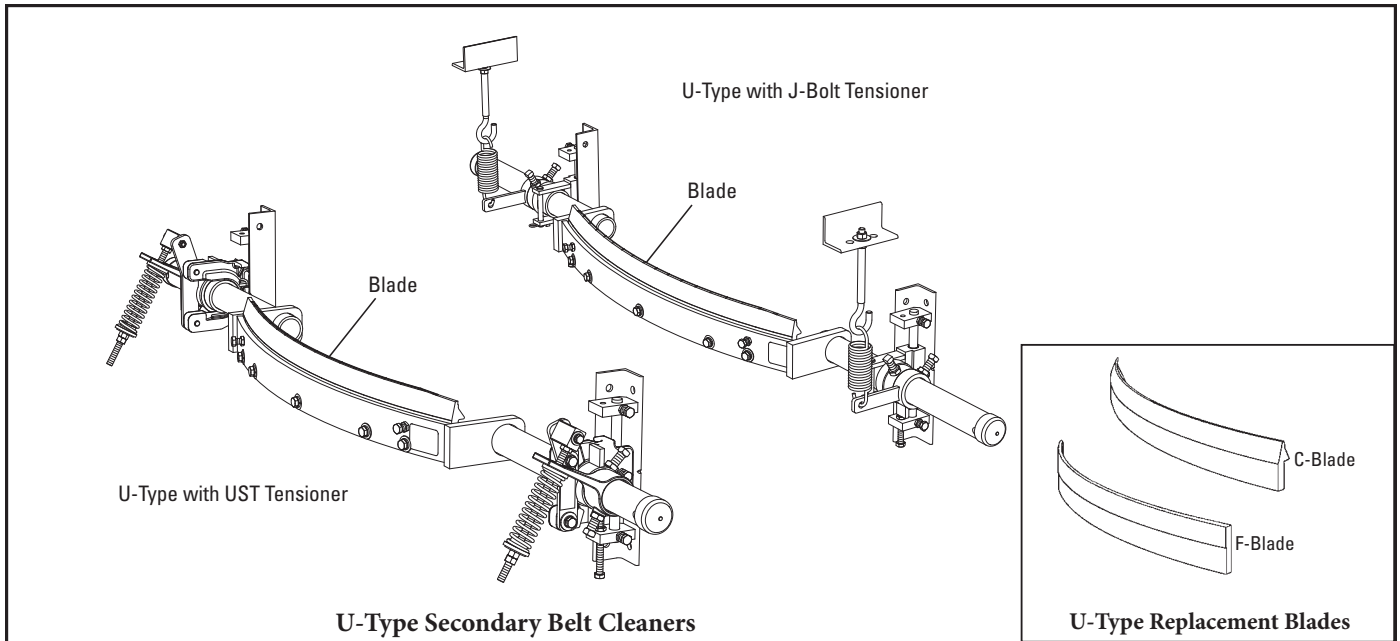

Physically lock out and tag the conveyor at the power source before you begin cleaner installation.

Tools Needed:
 - Tape measure
 - 3/4" (19mm) wrench
 - Wire brush

Double check the blade type needed for your application:
 F - Blade - for mechanically-spliced belts
 C-Blade - for Flexco Solid Plate mechanically spliced and vulcanized belts

1. Release the blade tension.

UST Spring Tensioner: Loosen the tension adjusting nuts on the tensioner pivot rods, allowing the pole to rotate the blade down (Fig. 1a).

J-Bolt Tensioner: Loosen both J-bolt jam nuts and remove the tensioner adjusting nuts and flat washers, allowing the pole to rotate against the stop collar and the blade to rotate down (Fig. 1b).

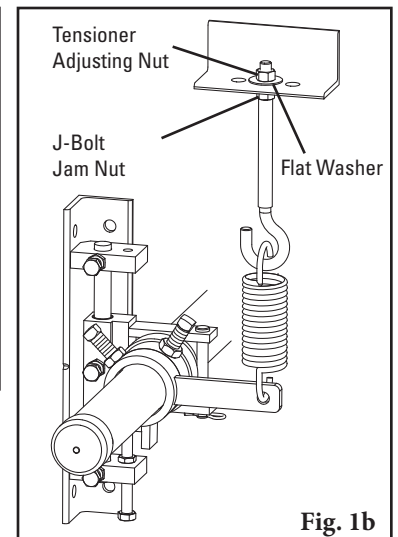
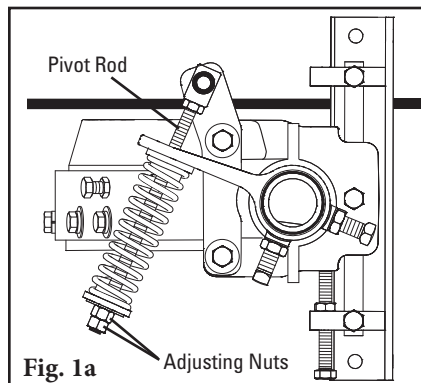

Section 6 - Maintenance

2. Remove the worn blade.

- a. Loosen both locknuts on the blade retaining screws. Turn blade retaining screws out 8 turns (Fig. 2a).
- b. Loosen or remove all plate retaining screws.
- c. From one end, insert a screwdriver under the blade and lightly pry the blade up and out of the blade holder (Fig. 2b). Once the blade breaks free, pull it out by hand.
- c. Remove the blade from the holder and clean material buildup from holder with a wire brush (Fig. 2c).

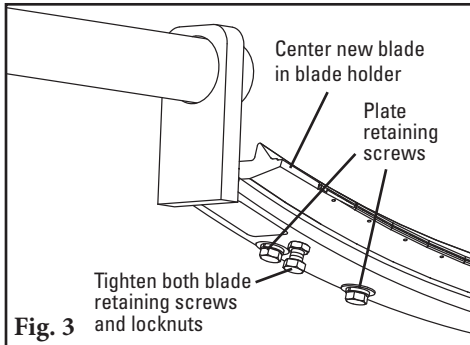
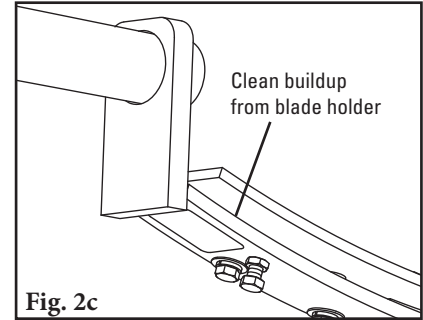
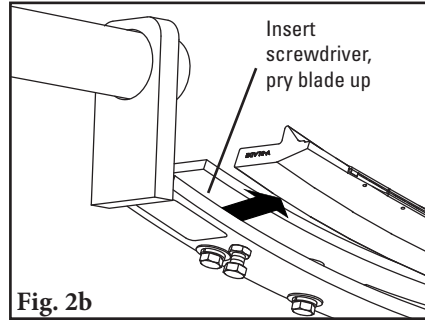
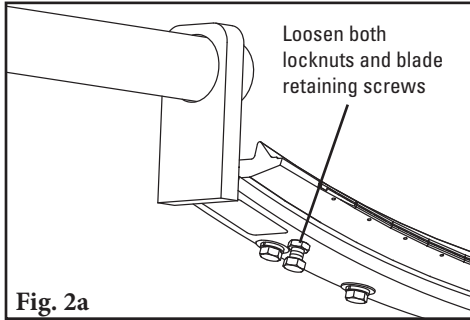

3. Install the new blade.

- a. Center the blade in the holder (Fig. 3).
- b. Tighten all plate retaining screws.
- c. Tighten blade retaining screws 8 turns and tighten the blade retaining screw locknuts (Fig 3).

4. Reset the blade tension.

UST Spring Tensioner: Refer to the chart for the spring length required for the belt width. Lightly pull the pivot arm toward the end of the torque arm slot nearest the pole and turn the adjusting nuts until the required spring length is achieved (Fig. 4a). **NOTE:** The chart is also on the cleaner's pivot shaft bracket for future reference for retensioning maintenance. Reference Section 4 (Cleaner Installation Instructions) on page 6.

J-Bolt Tensioner: Rotate the pole and insert the J bolts through the J bolt mount holes and install the flat washers and tensioner adjusting nuts. Turn the tensioner adjusting nuts until a .030" gap (use Spring Tension Gauge included with cleaner) appears between all coils of the tension spring (Fig. 4b). Lock both J bolt jam nuts.

Adjusting Nuts

Top of washer to top of torque arm

Fig. 4a

Spring Length Chart (for Cleaners with UST Tensioners)								
Blade Width		Purple Spring		Silver Spring		White Spring		
in.	mm	in.	mm	in.	mm	in.	mm	
18	450	6 1/8	154	6 3/8	160	6 3/8	162	
24	600	5 7/8	148	6 1/4	148	6 1/4	160	
30	750	5 1/2	140	6 1/8	156	6 1/4	158	
36	900	5 3/8	136	6	152	6 1/8	156	
42	1050	5	128	5 7/8	150	6 1/8	154	
48	1200	N/A	N/A	5 3/4	146	6	152	
54	1350	N/A	N/A	5 5/8	142	5 7/8	150	
60	1500	N/A	N/A	5 1/2	140	5 7/8	150	
72	1800	N/A	N/A	N/A	N/A	5 1/2	140	
84	2100	N/A	N/A	N/A	N/A	5 3/8	136	
96	2400	N/A	N/A	N/A	N/A	5 1/4	132	

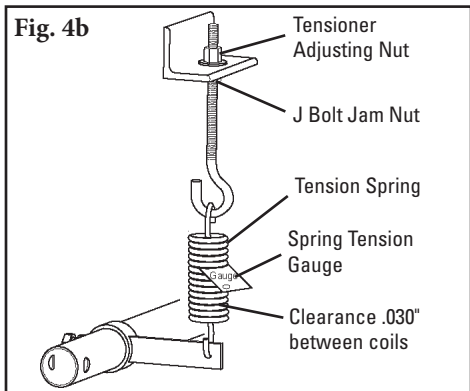

5. **Inspect for full blade contact to the belt.** Important - Always be sure there is uniform contact between the blade and the belt. If the blade is not in full contact with the belt at the edges and center, raise or lower the pole position of the cleaner and reapply the tension (See Installation Instructions).

Test run the cleaner. Run the conveyor for at least 15 minutes and inspect the cleaning performance. Check the spring length for proper tensioning. Make adjustments as necessary.

Section 6 - Maintenance

6.5 Maintenance Log

Conveyor Name/No. _____

Date: _____ Work done by: _____ Service Quote #: _____

Activity: _____

Date: _____ – _____ Work done by: _____ Service Quote #: _____

Activity: _____

Date: _____ – _____ Work done by: _____ Service Quote #: _____

Activity: _____

Date: _____ – _____ Work done by: _____ Service Quote #: _____

Activity: _____

Date: _____ – _____ Work done by: _____ Service Quote #: _____

Activity: _____

Date: _____ – _____ Work done by: _____ Service Quote #: _____

Activity: _____

Date: _____ – _____ Work done by: _____ Service Quote #: _____

Activity: _____



Section 6 - Maintenance

6.6 Cleaner Maintenance Checklist

Belt Cleaner: _____ **Serial Number:** _____

Beltline Information:

Beltline Number: _____ Belt Condition: _____

Belt Width: 18" 24" 30" 36" 42" 48" 54" 60" 72" 84" 96"
 (450mm) (600mm) (750mm) (900mm) (1050mm) (1200mm) (1350mm) (1500mm) (1800mm) (2100mm) (2400mm)

Head Pulley Diameter (Belt & Lagging): _____ Belt Speed: _____ fpm Belt Thickness: _____

Belt Splice: _____ Condition of Splice: _____ Number of Splices: _____ Skived Unskived

Material conveyed: _____

Days per week run: _____ Hours per day run: _____

Blade Life:

Date blade installed: _____ Date blade inspected: _____ Estimated blade life: _____

Is blade making complete contact with belt? Yes No

Distance from wear line: Left _____ Middle _____ Right _____

Blade condition: Good Grooved Smiled Not contacting belt Damaged

Measurement of spring: Required _____ Currently _____

Was Cleaner Adjusted: Yes No

Pole Condition: Good Bent Worn

Lagging: Side Lag Ceramic Rubber Other None

Condition of lagging: Good Bad Other _____

Cleaner's Overall Performance: (Rate the following 1 - 5, 1= very poor - 5 = very good)

Appearance: Comments: _____

Location: Comments: _____

Maintenance: Comments: _____

Performance: Comments: _____

Other comments _____

Section 7 - Troubleshooting

Problem	Possible Cause	Possible Solutions
Vibration	Cleaner secure bolts not set	Ensure all locking nuts are tight (Loctite)
	Cleaner not set up correctly	Ensure cleaner set up properly (1°-3° into belt)
	Belt tension too high	Ensure cleaner can conform to belt, or replace with alternate Flexco secondary cleaner
	Belt flap	Introduce hold-down roller to flatten belt
	Cleaner over-tensioned	Ensure cleaner is correctly tensioned
	Cleaner under-tensioned	Ensure cleaner is correctly tensioned
	Nylon bearing worn out or missing	Replace nylon bearing
Material buildup on cleaner	Cleaner not set up correctly	Ensure cleaner set up properly (1°-3° into belt)
	Buildup on chute	Ensure cleaner is not located too close to back of chute, allowing buildup
	Cleaner being overburdened	Introduce Flexco precleaner
	Excessive sticky material	Frequently clean unit of buildup
Damaged belt cover	Cleaner over-tensioned	Ensure cleaner is correctly tensioned
	Cleaner blade damage	Check blade for wear, damage and chips, replace where necessary
	Attack angle not correct	Ensure cleaner set up properly (1°-3° into belt)
	Material buildup in chute	Frequently clean unit of buildup
	Stop collar in incorrect position	Check stop collar tabs are not resting against slide plate
Cleaner not conforming to belt	Cleaner not set up correctly	Ensure cleaner set up properly (1°-3° into belt)
	Belt tension too high	Ensure cleaner can conform to belt, or replace with alternate Flexco secondary cleaner
	Belt flap	Introduce hold-down roller to flatten belt
	Cleaner cannot conform	Ensure cleaner can conform to belt, or replace with alternate Flexco secondary cleaner
Material passing cleaner	Cleaner not set up correctly	Ensure cleaner set up properly (1°-3° into belt)
	Cleaner tension too low	Ensure cleaner is correctly tensioned
	Cleaner blade worn/damaged	Check blade for wear, damage and chips, replace where necessary
	Cleaner being overburdened	Introduce Flexco precleaner
	Belt flap	Introduce hold-down roller to flatten belt
	Cleaner cannot conform	Ensure cleaner can conform to belt, or replace with alternate Flexco secondary cleaner
	Blade in backwards	Install blade correctly and set correct tension
	Stop collar in incorrect position	Check stop collar tabs are not resting against slide plate
Damage to mechanical fastener	Incorrect cleaner blade selection	Change blade type to accommodate fastener style (UC or UF)
	Belt not skived correctly	Spot and redo splice correctly, lowering the profile flush or below belt surface
	Stop collar in incorrect position	Check stop collar tabs are not resting against slide plate
Missing material in belt center only	Cleaner pole located too high	Ensure cleaner set up properly (1°-3° into belt)
	Cleaner blade worn/damaged	Check blade for wear, damage and chips, replace where necessary
Missing material on outer edges only	Cleaner pole located too low	Ensure cleaner set up properly (1°-3° into belt)
	Cleaner blade worn/damaged	Check blade for wear, damage and chips, replace where necessary

Section 8 - Specs and CAD Drawings

8.1 Specifications and Guidelines

Pole Length Specifications

CLEANER SIZE		POLE LENGTH		MAXIMUM CONVEYOR SPAN	
in.	mm	in.	mm	in.	mm
18	450	64	1600	54	1350
24	600	70	1750	60	1500
30	750	76	1900	66	1650
36	900	82	2050	72	1800
42	1050	88	2200	78	1950
48	1200	94	2350	84	2100
54	1350	100	2500	90	2250
60	1500	106	2650	96	2400
72	1800	124	3100	114	2850
84	2100	136	3400	126	3150
96	2400	148	3700	138	3450

Pole Diameter - 18" to 60" cleaners: 2-3/8" (60mm)

Pole Diameter - 72" and 96" cleaners: 2-7/8" (75mm)

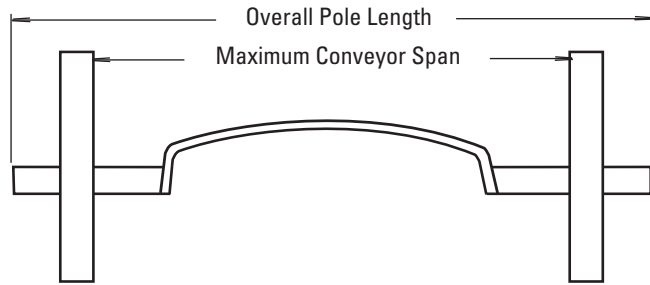

Cleaner Clearance Requirements

U Cleaner Size		Clearance	
in.	mm	in.	mm
18"	450	6	155
24"	600	7	180
30"	750	8	205
36"	900	8	205
42"	1050	9 1/4	235
48"	1200	10 1/2	270
54"	1350	10 3/4	275
60"	1500	10 3/4	275
72"	1800	10 3/4	275
84"	2100	10 3/4	275
96"	2400	10 3/4	275

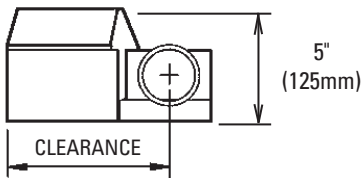

Spring Length Chart (For Cleaners with UST Tensioners)

BLADE WIDTH		PURPLE SPRING		SILVER SPRING		WHITE SPRING	
in.	mm	in.	mm	in.	mm	in.	mm
18	450	6 1/8	154	6 3/8	160	6 3/8	162
24	600	5 7/8	148	6 1/4	148	6 1/4	160
30	750	5 1/2	140	6 1/8	156	6 1/4	158
36	900	5 3/8	136	6	152	6 1/8	156
42	1050	5	128	5 7/8	150	6 1/8	154
48	1200	N/A	N/A	5 3/4	146	6	152
54	1350	N/A	N/A	5 5/8	142	5 7/8	150
60	1500	N/A	N/A	5 1/2	140	5 7/8	150
72	1800	N/A	N/A	N/A	N/A	5 1/2	140
84	2100	N/A	N/A	N/A	N/A	5 3/8	136
96	2400	N/A	N/A	N/A	N/A	5 1/4	132

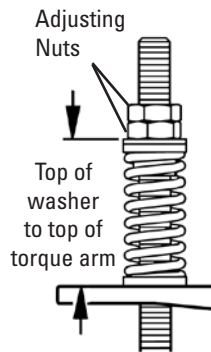

Spring Tensioner Guidelines

(For Stainless Steel Cleaners with J-Bolt Tensioners)

- Spring gap = .030" (.7mm)
- *Gauge provided

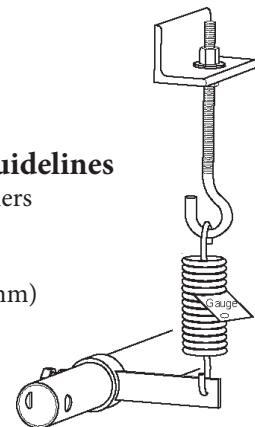

Specifications:

- Maximum Belt Speed..... 1300 FPM (6.6m/s); F-Blade - 1000 FPM (5m/s)
- Temperature Rating..... -30°F to 180°F (-35°C to 82°C)
- Usable Blade Wear Length..... C-Blade - 3/8" (9mm); F-Blade - 1 3/4" (44mm)
- Available for Belt Widths..... 18" to 96" (450 to 2400mm).
Other sizes available upon request.
- CEMA Cleaner Rating..... Class 5

Section 8 - Specs and CAD Drawings

8.2 CAD Drawing - U-Type® Cleaners with UST Tensioners

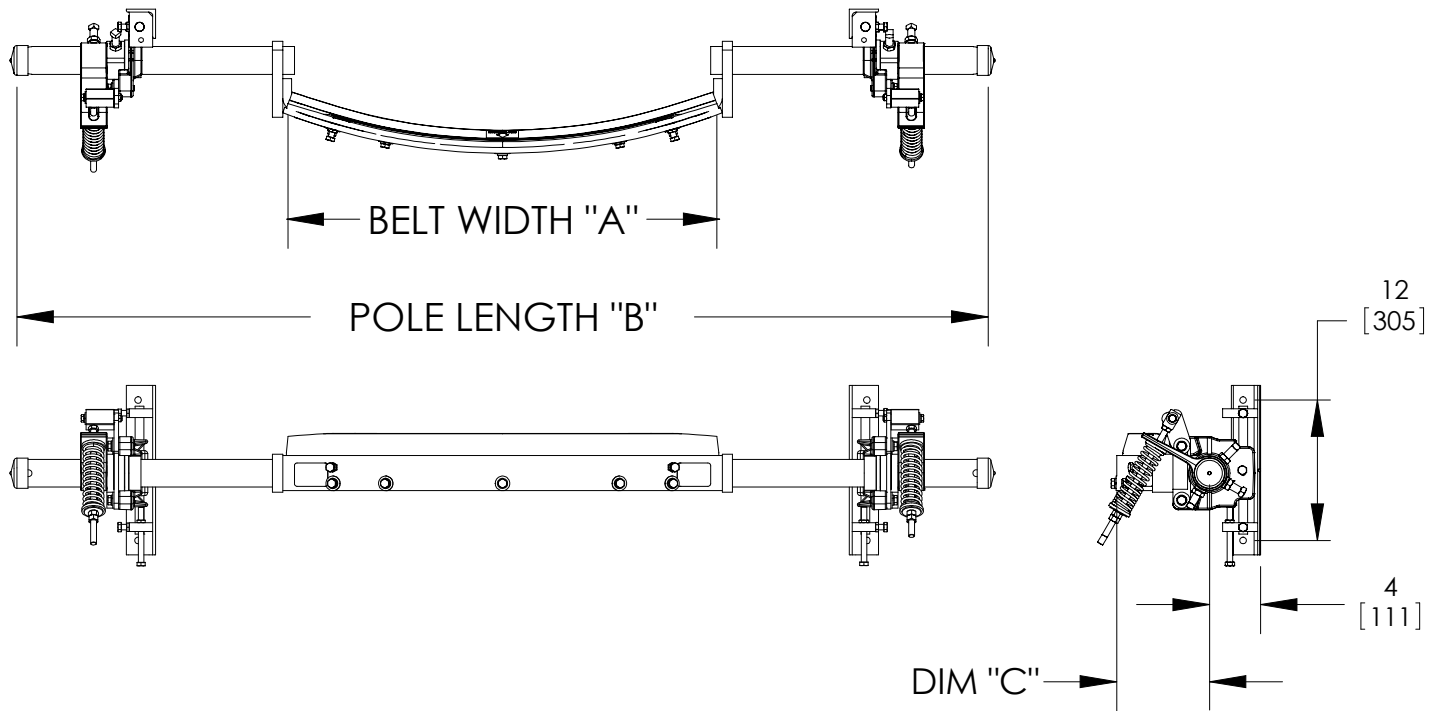

UST U-Type Mild Steel Cleaners - Imperial Mounting Fasteners

C-Blade Cleaner	F-Blade Cleaner	Belt Width "A"		Pole Length "B"		Dim "C"	
		in	mm	in	mm	in	mm
76712	76724	18	450	64	1600	5.91	150
76713	76725	24	600	70	1750	6.85	174
76714	76726	30	750	76	1900	8.00	203
76715	76727	36	900	82	2050	8.00	203
76716	76728	42	1050	88	2200	9.14	232
76717	76729	48	1200	94	2350	10.48	266
76718	76730	54	1350	100	2500	10.57	268
76719	76731	60	1500	106	2650	10.51	267
76720	76732	72	1800	124	3100	10.58	269
76721	76733	84	2100	136	3400	10.11	257
79239	79240	96	2400	148	3700	10.69	272

Section 8 - Specs and CAD Drawings

8.2 CAD Drawing - Stainless Steel U-Type® Cleaners with J-Bolt Tensioners

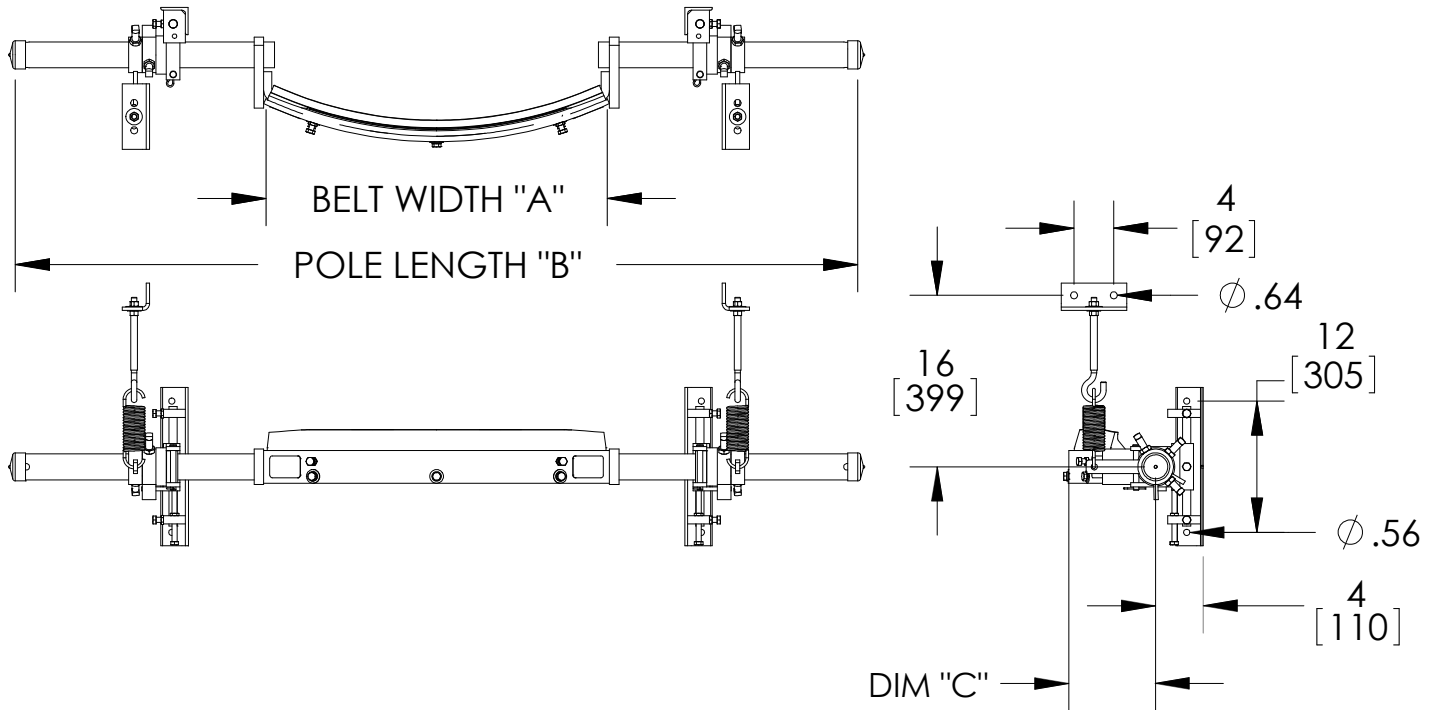

J-Bolt U-Type Stainless Steel Cleaners - Imperial Mounting Fasteners

C-Blade Cleaner	Belt Width "A"		Pole Length "B"		Dim "C"	
	in	mm	in	mm	in	mm
77395	18	450	64	1600	5.91	150
77396	24	600	70	1750	6.85	174
77397	30	750	76	1900	8.00	203
77398	36	900	82	2050	8.00	203
77399	42	1050	88	2200	9.14	232
77400	48	1200	94	2350	10.48	266
77401	54	1350	100	2500	10.57	268
77402	60	1500	106	2650	10.51	267
77403	72	1800	124	3100	10.58	269
77404	84	2100	136	3400	10.11	257

Section 9 - Replacement Parts

9.1 Replacement Parts List - U-Type® with UST Tensioners

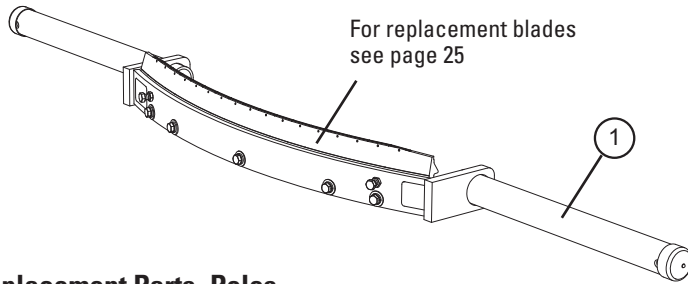

Replacement Parts—Poles

REF	DESCRIPTION	ORDERING NUMBER	ITEM CODE	WT. LBS.
1	18" (450mm) Pole	USP18/450	76772	45.0
	24" (600mm) Pole	USP24/600	76773	50.0
	30" (750mm) Pole	USP30/750	76774	56.0
	36" (900mm) Pole	USP36/900	76775	60.0
	42" (1050mm) Pole	USP42/1050	76776	65.0
	48" (1200mm) Pole	USP48/1200	76777	71.0
	54" (1350mm) Pole	USP54/1350	76778	76.0
	60" (1500mm) Pole	USP60/1500	76779	82.0
	72" (1800mm) Pole	USP72/1800	76780	125.0
	84" (2100mm) Pole	USP84/2100	76781	138.0
	96" (2400mm) Pole	USP96/2400	79241	152.0

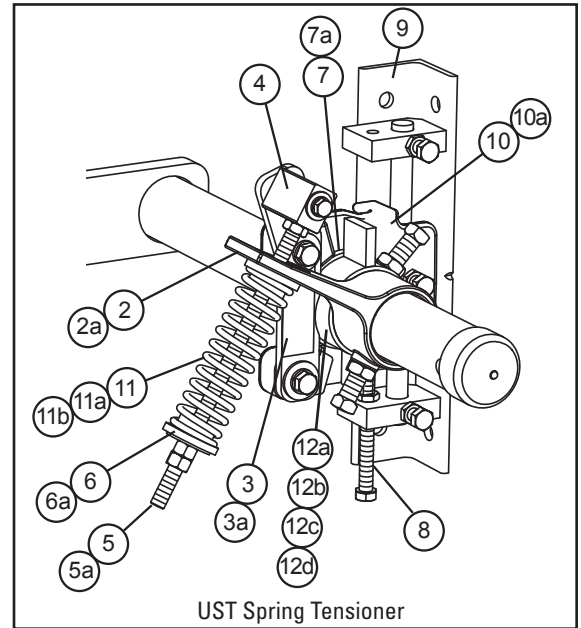

UST Spring Tensioner

Replacement Parts—U-Type Mild Steel - UST Tensioners

REF	DESCRIPTION	ORDERING NUMBER	ITEM CODE	WT. LBS.
2	Torque Arm Kit* (1 ea.) †Δ	ESTAK-EST	76406	3.6
2a	Torque Arm Kit HD* (1 ea.) §	PSTA	75896	11.4
3	Pivot Shaft Bracket Kit* (1 ea.) †Δ	UPSBK	76784	1.7
3a	Pivot Shaft Bracket Kit HD* (1 ea.) §	QMTPSBK	76099	4.3
4	Pivot Block Kit* (1 ea.) †Δ	UPBK	76785	1.0
5	Pivot Rod Kit* (1 ea.) †Δ	ESPRK	76409	1.2
5a	Pivot Rod Kit HD* (1 ea.) §	QMTPAK	76096	4.3
6	Bushing Kit (incl. 2 bushings) †Δ	ESBK-PS	76410	0.1
6a	Bushing Kit HD (incl. 2 bushings) §	QMTBK-W	76098	0.1
7	Standard Pole Bearing (1 ea.) †Δ	USPB2	79206	0.13
7a	HD Pole Bearing (1 ea.) §	UHPB2	79207	0.15
8	Adjusting Bolt Kit (1 ea.) (incl. locknut)	ABU	76788	0.2
9	Mounting Bracket Kit* (1 ea.)	UMBK	76789	9.7
10	Slide Plate Kit* (1 ea.) †Δ	USPK	76790	4.6
10a	HD Slide Plate Kit* (1 ea.) §	UHSPK	76791	5.2
11	Tension Spring - Purple (1 ea.) †	QMTS-P	75845	0.6
11a	Tension Spring - Silver (1 ea.) Δ	ESS-S	76412	1.2
11b	Tension Spring - White (1 ea.) §	PSTS-W	75898	1.7
12a	UST Stop Collar Retrofit Kit †Δ	USTSCK	79202	2.5
12b	UST Stop Collar Retrofit Kit - S/S †Δ	USTSCK-S/S	79203	2.5
12c	HD UST Stop Collar Retrofit Kit §	USTSCKHD	79204	3.7
12d	HD UST Stop Collar Retrofit Kit - S/S §	USTSCKHD-S/S	79205	3.7
—	UST Spring Tensioner* - Purple † (incl. 1 ea. items 2, 3, 4, 5, 6, 8, 9, 10, 11)	UST-P	76794	25.0
—	UST Spring Tensioner* - Silver Δ (incl. 1 ea. items 2, 3, 4, 5, 6, 8, 9, 10, 11a)	UST-S	76795	25.0
—	UST Spring Tensioner* - White § (incl. 1 ea. items 2a, 3a, 4, 5a, 6a, 8, 9, 10a, 11b)	UST-W	77757	40.0
—	Standard Mounting Kit* (incl. 1 ea. items 8, 9, 10) † Δ (for blade widths 18" - 60" (450 - 1500mm))	USMK	76792	14.6
—	HD Mounting Kit* (incl. 1 ea. items 8, 9, 10a) § (for blade widths 72" - 96" (1800 - 2400mm))	UHMK	76793	15.5

*Hardware included

† Standard components for blade widths 18"-42" (450-1050mm)

Δ Standard components for blade widths 48"-60" (1200-1500mm)

§ HD components for blade widths 72"-96" (1800-2400mm)

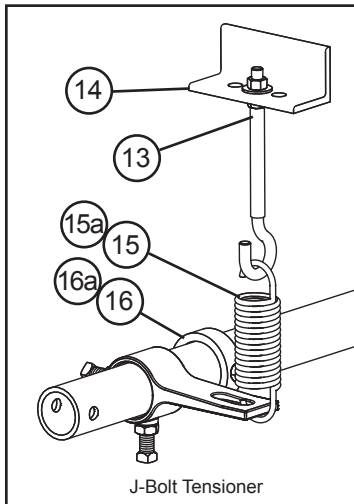

J-Bolt Tensioner

For use in changing UST Spring Tensioner to a J-Bolt Tensioner

Replacement Parts—J-bolt Tensioner

REF	DESCRIPTION	ORDERING NUMBER	ITEM CODE	WT. LBS.
13	J-Bolt (incl. locknut and washer)	STJK	74417	0.7
14	J-Bolt Mount (1 ea.)	STJM	74775	3.0
15	Tension Spring (1 ea.) †	STTS	74419	1.4
15a	HD Tension Spring (1 ea.) §	HDTTS	74502	2.0
16	Pole Lock Collar †	EZP1PL	75641	1.1
16a	HD Pole Lock Collar §	MSPPL	75816	1.9
—	J-Bolt Tensioner Kit † (Optional) (incl. 2 ea. items 13, 14, 15, 16)	UBTK	76977	4.7
—	HD J-Bolt Tensioner Kit § (Optional) (incl. 2 ea. items 13, 14, 15a, 16a)	UHDBTK	76978	5.2

† Standard components for blade widths 18"-60" (450-1500mm)

§ HD components for blade widths 72"-96" (1800-2400mm)

Section 9 - Replacement Parts

9.2 Replacement Parts List - Stainless Steel U-Type® with J-Bolt Tensioners

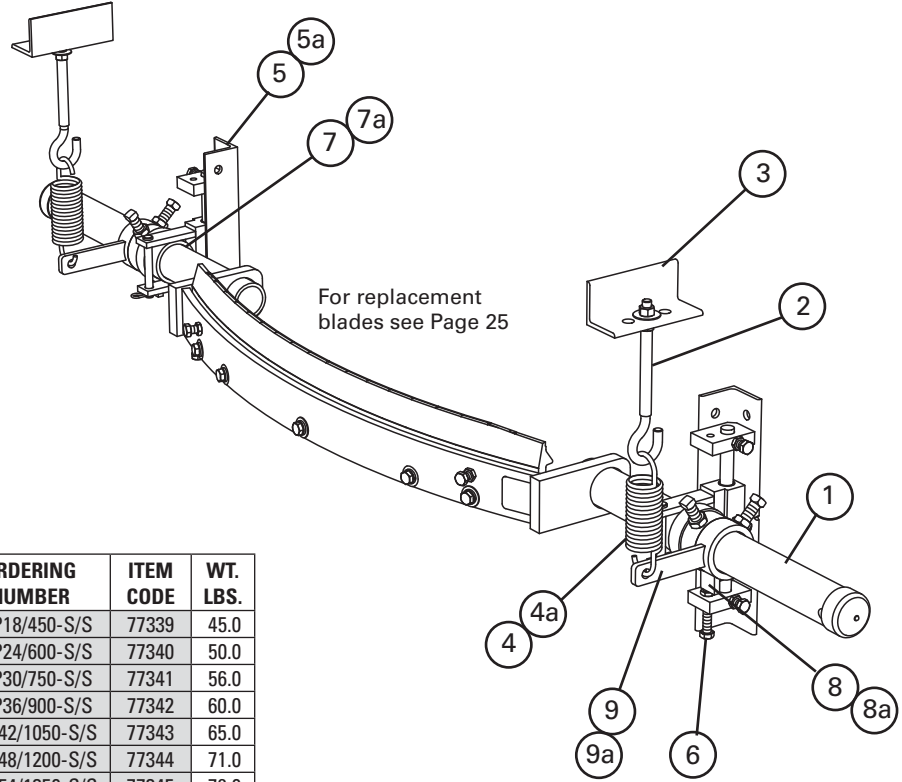

U-Type® Stainless Replacement Parts

REF	DESCRIPTION	ORDERING NUMBER	ITEM CODE	WT. LBS.
1	18" (450mm) Pole	USP18/450-S/S	77339	45.0
	24" (600mm) Pole	USP24/600-S/S	77340	50.0
	30" (750mm) Pole	USP30/750-S/S	77341	56.0
	36" (900mm) Pole	USP36/900-S/S	77342	60.0
	42" (1050mm) Pole	USP42/1050-S/S	77343	65.0
	48" (1200mm) Pole	USP48/1200-S/S	77344	71.0
	54" (1350mm) Pole	USP54/1350-S/S	77345	76.0
	60" (1500mm) Pole	USP60/1500-S/S	77347	82.0
	72" (1800mm) Pole	USP72/1800-S/S	77349	125.0
84" (2100mm) Pole	USP84/2100-S/S	77351	138.0	
2	J-Bolt Kit* (incl. locknut and washer)	STJK-S/S	77334	0.7
3	J-Bolt Mount (1 ea.)	STJM-S/S	77332	3.0
4	18 - 60" Tension Spring (1 ea.)	STTS-S/S	75585	1.0
4a	64"+ Tension Spring (1 ea.)	HDTS-S/S	75586	1.5
5	18 - 60" Mounting Bracket Kit (incl. R & L)	USMK-S/S-M	82885	16.0
5a	64"+ Mounting Bracket Kit (incl. R & L)	USMKHD-S/S-M	82886	19.0
6	Adjusting Bolt Kit (incl. locknut)	ABU	76788	1.0
7	18 - 60" UHMW Bearing (1 ea.)	USPB2	79206	1.0
7a	64"+ UHMW Bearing (1 ea.)	UHPB2	79207	1.0
8	18 - 60" Stop Collar* (1 ea.)	UPL-S/S-MT	82810	2.0
8a	64"+ Stop Collar* (1 ea.)	UPLHD-S/S-MT	82811	2.0
9	18 - 60" Adjusting Arm* (1 ea.)	HARK-S/S	77364	2.0
9a	64"+ Adjusting Arm* (1 ea.)	HDARK-S/S	77331	2.0
-	18 - 60" Mounting Kit* (incl. 2 ea. items 2, 3, 4, 5, 6, 7, 8, & 9)	MMKU-S/S	77357	40.0
-	64"+ Mounting Kit* (incl. 2 ea. items 2, 3, 4a, 5a, 6, 7a, 8a, & 9a)	MMKUHD-S/S	77358	43.0

*Hardware included
Lead time: 1 working day

Shaded items are made to order.
Lead time: 5 weeks

Section 9 - Replacement Parts

9.3 Replacement Blades

U-Type C-Blades (Impact Resistant Tungsten Carbide)*

BELT WIDTH		ORDERING NUMBER	ITEM CODE	WT. LBS.
IN.	MM			
18	450	URCB18/450	76748	5.0
24	600	URCB24/600	76749	6.7
30	750	URCB30/750	76750	8.4
36	900	URCB36/900	76751	10.1
42	1050	URCB42/1050	76752	11.7
48	1200	URCB48/1200	76753	13.5
54	1350	URCB54/1350	76754	15.0
60	1500	URCB60/1500	76755	16.8
72	1800	URCB72/1800	76756	20.2
84	2100	URCB84/2100	76757	23.5
96	2400	URCB96/2400	76758	30.0

*NOTE: C-Blades can be used on Flexco® Solid Plate, mechanically fastened and vulcanized belts.

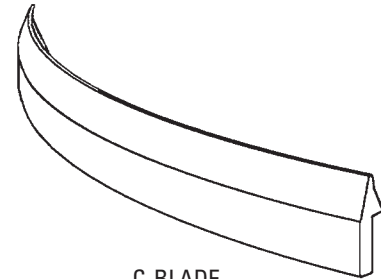

C-BLADE

U-Type F-Blades (Urethane)*

BELT WIDTH		ORDERING NUMBER	ITEM CODE	WT. LBS.
IN.	MM			
18	450	UFB18	74448	3.0
24	600	UFB24	74449	4.0
30	750	UFB30	74450	5.0
36	900	UFB36	74451	6.0
42	1050	UFB42	74452	7.0
48	1200	UFB48	74453	8.0
54	1350	UFB54	74454	9.0
60	1500	UFB60	74455	10.0
72	1800	UFB72	74456	12.0
84	2100	UFB84	74460	14.0
96	2400	UFB96	74461	16.0

*NOTE: F-Blades (Urethane) can be used on mechanically fastened belts and vulcanized belts.

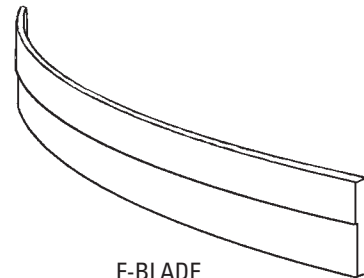

F-BLADE

Section 10 - Other Flexco Conveyor Products

Flexco provides many conveyor products that help your conveyors to run more efficiently and safely. These components solve typical conveyor problems and improve productivity. Here is a quick overview on just a few of them:

MMP Precleaner



- Extra cleaning power right on the head pulley
- A 10" (250mm) TuffShear™ blade provides increased blade tension on the belt to peel off abrasive materials
- The unique Visual Tension Check™ ensures optimal blade tensioning and quick, accurate retensioning
- Easy to install and simple to service

DRX Impact Beds



- Exclusive Velocity Reduction Technology™ to better protect the belt
- Slide-Out Service™ gives direct access to all impact bars for change-out
- Impact bar supports for longer bar life
- 4 models to custom fit to the application

MHS Secondary Cleaner with Service Advantage Cartridge

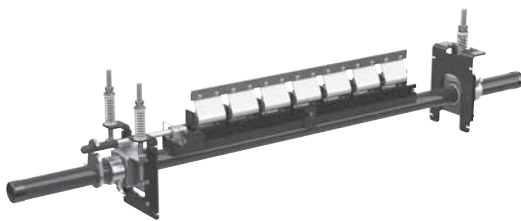

- An easy slide-out cartridge for service
- Cartridge design to speed up blade-change maintenance
- Patented PowerFlex™ Cushions for superior cleaning performance
- Compatible with Flexco mechanical splices

PT Max™ Belt Trainer



- Patented “pivot & tilt” design for superior training action
- Dual sensor rollers on each side to minimize belt damage
- Pivot point guaranteed not to seize or freeze up
- Available for topside and return side belts

Flexco Specialty Belt Cleaners



- “Limited space” cleaners for tight conveyor applications
- High Temp cleaners for severe, high heat applications
- A rubber-fingered cleaner for chevron and raised-rib belts
- Multiple cleaner styles in stainless steel for corrosive applications

Belt Plows



- A belt cleaner for the tail pulley
- Exclusive blade design quickly spirals debris off the belt
- Economical and easy to service
- Available in vee or diagonal models

The Flexco Vision

To become the leader in maximising
belt conveyor productivity for our customers worldwide
through superior service and innovation.



2525 Wisconsin Avenue • Downers Grove, IL 60515-4200 • USA
Tel: (630) 971-0150 • Fax: (630) 971-1180 • E-mail: info@flexco.com

Visit www.flexco.com for other Flexco locations and products.

©2019 Flexible Steel Lacing Company. 9/16/19. X3158

