

EZP1 Primary Cleaner

Installation, Operation and Maintenance Manual



EZP1 Primary Cleaner

Purchase Date: _____

Purchased From: _____

Installation Date: _____

This information will be helpful for any future inquiries or questions about belt cleaner replacement parts, specifications or troubleshooting.

Table of Contents

Section 1 – Important Information	4
1.1 General Introduction	4
1.2 User Benefits	4
1.3 Service Option	4
Section 2 – Safety Considerations and Precautions	5
2.1 Stationary Conveyors	5
2.2 Operating Conveyors	5
Section 3 – Pre-Installation Checks and Options.....	6
3.1 Checklist	7
3.2 Cleaner Location Adjustments	7
Section 4 – Installation Instructions.....	8
Section 5 – Pre-Operation Checklist and Testing.....	11
5.1 Pre-Op Checklist	11
5.2 Test Run the Conveyor	11
Section 6 – Maintenance	12
6.1 New Installation Inspection	12
6.2 Routine Visual Inspection	12
6.3 Routine Physical Inspection.....	12
6.4 Blade Replacement Instructions.....	13
6.5 Maintenance Log	15
6.6 Cleaner Maintenance Checklist.....	16
Section 7 – Troubleshooting	17
Section 8 – Specs and CAD Drawings.....	18
8.1 EZP1 Primary Cleaner CAD drawings (-50" and -200")	19
8.2 EZP1 Hi-Temp Primary Cleaner CAD drawing (-50")	20
Section 9 – Replacement Parts	21
9.1 EZP1 Powder Coat	21
8.1 EZP1 Stainless Steel.....	22
Section 10 – Other Flexco Conveyor Products.....	23

Section 1 – Important Information

1.1 General Introduction

We at Flexco are very pleased that you have selected an EZP1 Primary Cleaner for your conveyor system.

This manual will help you to understand the operation of this product and assist you in making it work up to its maximum efficiency over its lifetime of service.

It is essential for safe and efficient operation that the information and guidelines presented be properly understood and implemented. This manual will provide safety precautions, installation instructions, maintenance procedures and troubleshooting tips.

If, however, you have any questions or problems that are not covered, please contact your field representative or our Customer Service Department:

Customer Service: 612-8818-2000

Visit www.flexco.com for other Flexco locations and products.

Please read this manual thoroughly and pass it on to any others who will be directly responsible for installation, operation and maintenance of this cleaner. While we have tried to make the installation and service tasks as easy and simple as possible, **it does however require correct installation and regular inspections and adjustments to maintain top working condition.**

1.2 User Benefits

Correct installation and regular maintenance will provide the following benefits for your operation:

- Reduced conveyor downtime
- Reduced man-hour labour
- Lower maintenance budget costs
- Increased service life for the belt cleaner and other conveyor components

1.3 Service Option

The EZP1 Primary Cleaner is designed to be easily installed and serviced by your on-site personnel. However, if you would prefer complete turn-key factory service, please contact your local Flexco Field Representative.

Section 2 – Safety Considerations and Precautions

Before installing and operating the EZP1 Primary Cleaner, it is important to review and understand the following safety information.

There are set-up, maintenance and operational activities involving both **stationary** and **operating** conveyors. Each case has a safety protocol.

2.1 Stationary Conveyors

The following activities are performed on stationary conveyors:

- Installation
- Blade replacement
- Repairs
- Tension adjustments
- Cleaning

DANGER

It is imperative that Lockout/Tagout (LOTO) regulations, be followed before undertaking the preceding activities. Failure to use LOTO exposes workers to uncontrolled behaviour of the belt cleaner caused by movement of the conveyor belt. Severe injury or death can result.

Before working:

- Lockout/Tagout the conveyor power source
- Disengage any takeups
- Clear the conveyor belt or clamp securely in place

WARNING

Use Personal Protective Equipment (PPE):

- Safety eyewear
- Hardhats
- Safety footwear

Close quarters, springs and heavy components create a worksite that compromises a worker's eyes, feet and skull.

PPE must be worn to control the foreseeable hazards associated with conveyor belt cleaners. Serious injuries can be avoided.

2.2 Operating Conveyors

There are two routine tasks that must be performed while the conveyor is running:

- Inspection of the cleaning performance
- Dynamic troubleshooting

DANGER

Every belt cleaner is an in-running nip hazard. Never touch or prod an operating cleaner. Cleaner hazards cause instantaneous amputation and entrapment.

WARNING

Belt cleaners can become projectile hazards. Stay as far from the cleaner as practical and use safety eyewear and headgear. Missiles can inflict serious injury.

WARNING

Never adjust anything on an operating cleaner. Unforeseeable belt projections and tears can catch on cleaners and cause violent movements of the cleaner structure. Flailing hardware can cause serious injury or death.

Section 3 – Pre-installation Checks and Options

3.1 Checklist

- Check that the cleaner size is correct for the beltline width
- Check the belt cleaner carton and make sure all the parts are included
- Review the “Tools Needed” list on the top of the installation instructions
- Check the conveyor site:
 - Will the cleaner be installed on a chute
 - Is the install on an open head pulley requiring mounting structure
 - Are there obstructions that may require cleaner location adjustments (see 3.2 – Cleaner Location Adjustments)

Section 3 – Pre-installation Checks and Options

3.2 Cleaner Location Adjustments

In certain applications it is necessary to modify the location of the precleaner pole due to permanent obstacles that obstruct the desired location. Relocating the pole location can be done easily and does not hinder the performance of the cleaner as long as the “C” dimension is maintained.

NOTE: In the following example we will be lowering the pole location in the “Y” direction, but the same method could also be applied in the “X” direction.

Conveyor situation:

Pulley Diameter: 600mm (24")

X = 300mm (12")

Y = 225mm (9")

C = 375 (15")

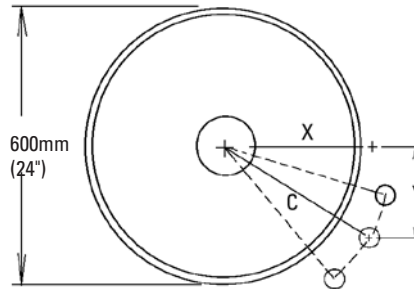

- Determine the given location dimensions and define the change needed.** After laying out the given X & Y dimensions, determine the distance of the modification required for adequate clearance of the pole and tensioning system. (In the example we decide to lower the pole 2" (50mm) to clear the support structure).
- Write down known dimensions.** We can now determine two of the three required dimensions which will allow us to find the third. We know we cannot alter the “C” dimension, so this will remain the same. Also we are required to lower the unit in the “Y” dimension 50mm (2"), so we add 50mm (2") to the given “Y” dimension.

X = ?"

Y = 225+50=275mm (9+2=11")

C = 375mm (15")

- Determine final dimension.** On a flat vertical surface, using a level, draw one horizontal line and one vertical line creating a right triangle (Fig 3a). Measure down from the intersection the determined “Y” dimension and mark (Fig 3b). With the tape measure starting at the modified “Y” mark, swing the tape across the “X” line and mark at the “C” dimension where it crosses the “X” line (Fig 3c). Measure from the intersection to the “C” intersection and this will be your new “X” dimension (Fig. 3d).

X = 255mm (10 1/4")

Y = 275mm (11")

C = 375mm (15")

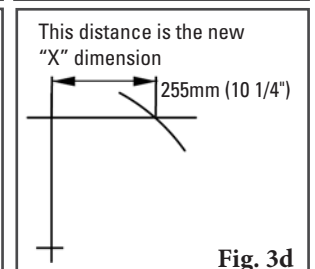
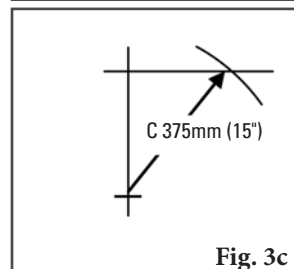
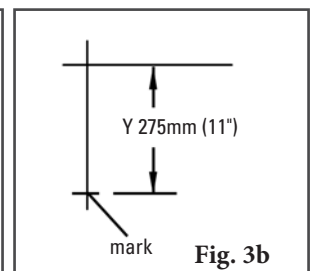
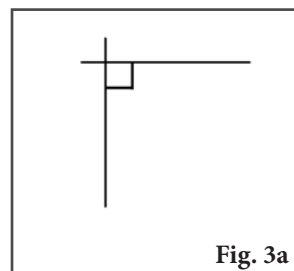

Section 4 – Installation Instructions

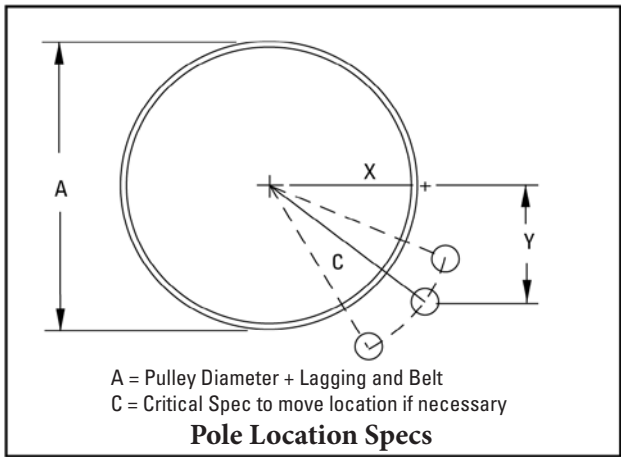
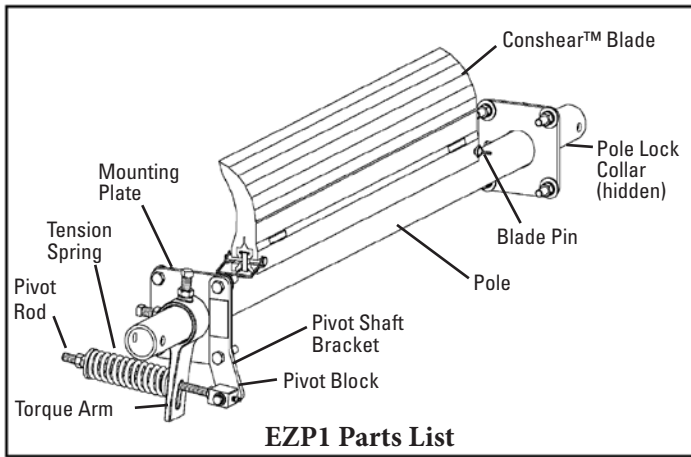

Physically lock out and tag the conveyor at the power source before you begin cleaner installation.

Tools Needed

- 13mm (1/2") Wrench
 - 16mm (5/8") Wrench
 - 19mm (3/4") Wrench
 - 22mm (7/8") Wrench
- OR**
- Large Adjustable/Crescent Wrenches (x2)
 - Torch (as needed)
 - Welder (as needed)
 - Tape Measure
 - Level
 - Marking Pen or Soapstone

Installation specs and instructions are based on the assumption that the conveyor is in its working position (angle). If the conveyor angle will be different, the cleaner should be installed per the final position.

1. Locate the correct pole position. Measure and determine Dimension A (see instructions above). Find Dimension A on the Pole Location Chart at right and determine Dimensions X, Y and C. Measure out horizontally from the centre of the pulley shaft Dim X and mark. From that mark, draw a long vertical line down, then measure and mark Dim Y. This indicates the location of the centre of the cleaner pole. Measure and mark both sides. **NOTE:** If the location is obstructed, use Dim. C and move on an arc from the centre of the pulley shaft to find an open position. Dim. C must remain constant to correctly locate the pole (see drawing above). **NOTE:** For open head installs, first add mounting support materials to the structure.

2. Mark and cut the mounting plate holes. Using the mounting plate template provided in the instruction packet, position the large pole access hole on the chute, aligning the hole notches with the layout lines. Position the keyway toward the pulley. Trace the pole cutout and mounting holes (Fig. 1). Cut the holes on both sides of the chute.

NOTE: Hole cutouts are slotted for later adjustment if needed.

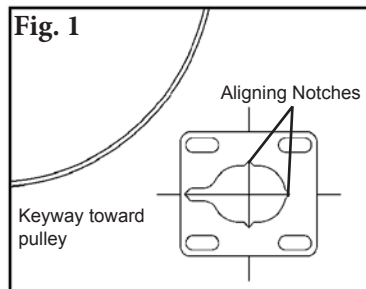

Pole Location Chart

A	X	Y	C
250	74	230	242
275	92	230	248
300	108	230	254
325	131	230	265
350	146	230	273
375	166	230	284
400	179	230	291
425	195	230	301
450	207	230	309
475	223	230	320
500	235	230	329
525	249	230	339
550	266	230	352
575	283	230	365
600	299	230	377
625	314	230	390
650	330	230	402
675	346	230	415
700	360	230	427
725	374	230	439
775	389	230	452
775	403	230	464
825	417	230	477
825	432	230	489
850	446	230	501
875	460	230	514
900	474	230	526

Section 4 – Installation Instructions (cont.)

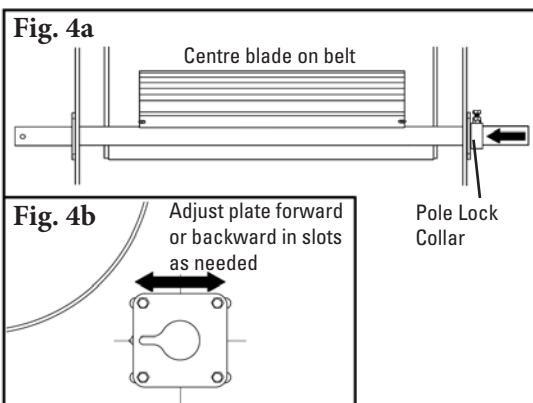
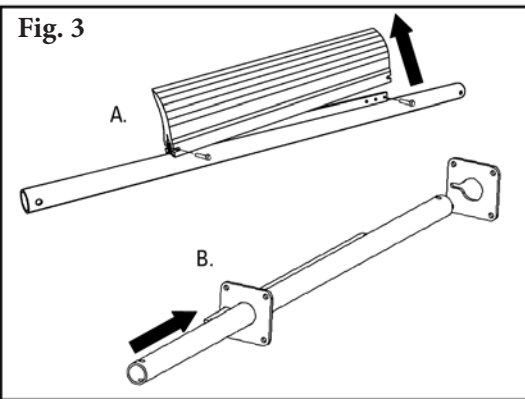
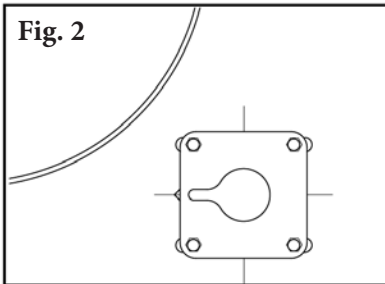

3. **Install the mounting plates.** Bolt the mounting plates to the chute with bolts provided. Centre plates on the slotted holes and tighten bolts (Fig. 2).
4. **Install the pole.** Remove both blade pins and blade from the pole and insert the pole in through the mounting plates (Fig. 3).
5. **Centre the cleaner on the belt and lock in place.** Reinstall the blade with both blade pins. Centre the blade on the belt and install the pole lock collar onto the pole (on the end opposite the end to be used for the tensioner), snugly up to the mounting plate (Fig. 4a). Rotate the blade up to the belt and check to insure that the blade is square to the pulley face. If not, loosen a mounting plate on one side and adjust the plate forward or backward to square the blade to the pulley, and retighten the bolts (Fig. 4b).

NOTE: The tensioner is assembled for installation on the left side (as you face the head pulley) of the cleaner. If right side installation is desired, some minor reassembly is required.

For step-by-step instructions, see the EST Tensioner Card included with the tensioner parts.

6. **Install the tensioner.** Determine desired side and position (Fig. 5a) (the tensioner can be installed in any position 360° around the pole as shown in Fig. 5b) and remove the two mounting plate bolts needed to install the pivot shaft bracket. With the pivot rod inserted through the slotted hole of the torque arm, slide the two components onto the pole together. Using the long bolts provided, fasten the pivot shaft bracket to the mounting plate and tighten (Fig. 5c).

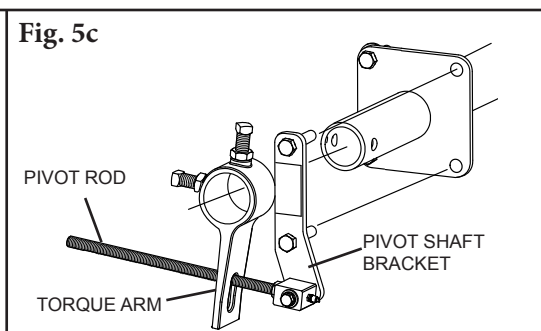
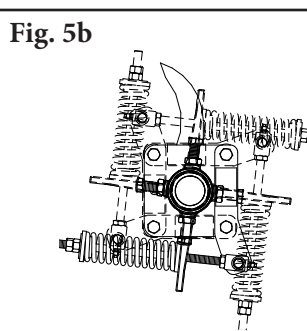
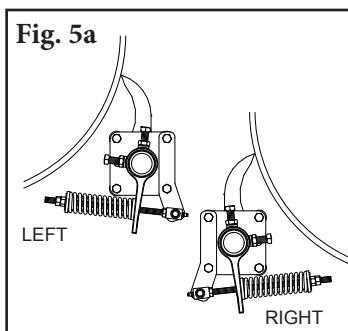

Section 4 – Installation Instructions (cont.)

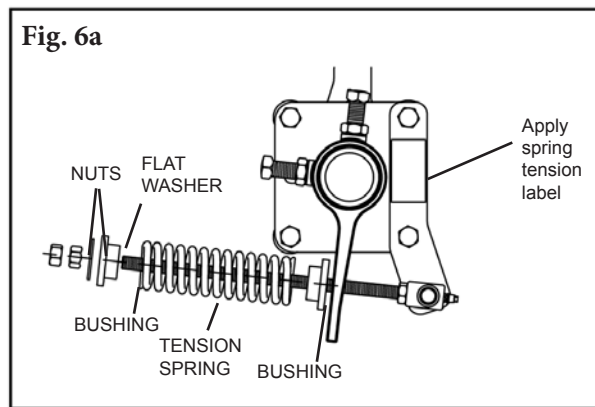

Blade Tension Chart

Blade Width		Purple Springs		Silver Springs		Black Springs	
mm	in.	mm	in.	mm	in.	mm	in.
250	10"	146	5 3/4"	159	6 1/4"	N/A	N/A
400	16"	133	5 1/4"	152	6"	N/A	N/A
550	22"	121	4 3/4"	149	5 7/8"	N/A	N/A
700	28"	108	4 1/4"	143	5 5/8"	N/A	N/A
850	34"	N/A	N/A	137	5 3/8"	143	5 5/8"
1000	40"	N/A	N/A	130	5 1/8"	140	5 1/2"
1150	46"	N/A	N/A	127	5"	133	5 1/4"
1300	52"	N/A	N/A	121	4 3/4"	130	5 1/8"
1450	58"	N/A	N/A	N/A	N/A	127	5"
1600	64"	N/A	N/A	N/A	N/A	121	4 3/4"
1750	70"	N/A	N/A	N/A	N/A	117	4 5/8"

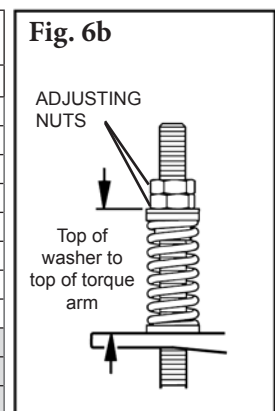

7. **Set the blade tension.** Assemble the tensioner by sliding the spring with bushings onto the pivot rod, followed by the large washer and two tension nuts (Fig. 6a). Thread nuts onto the pivot rod to expose 1" (25mm) of the end. Rotate the pole until the blade contacts the pulley. While pulling the torque arm up to the spring, tighten the torque arm to the pole. Set spring length to determined length (Fig. 6b.) Apply the spring tension label (provided in the instruction packet) to the pivot shaft bracket as shown.

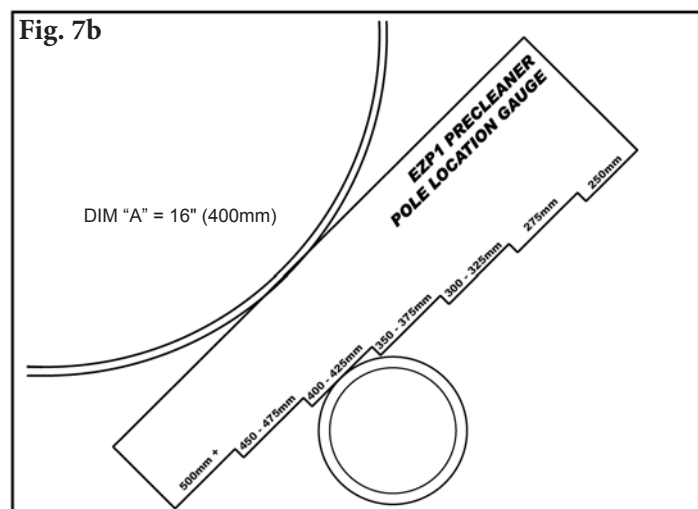
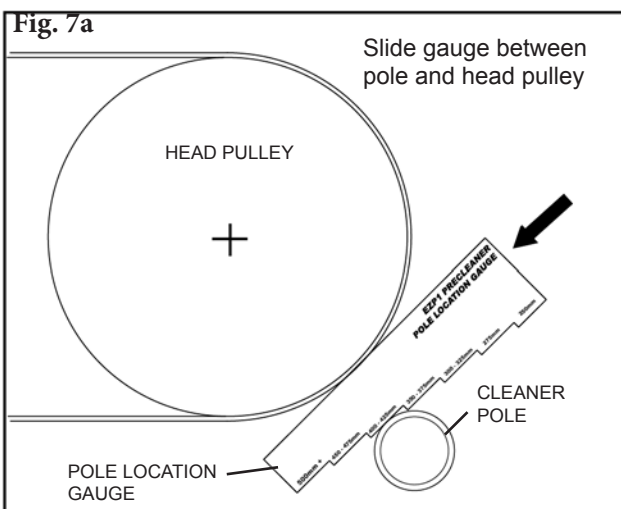

8. **Confirm correct pole location.** After the cleaner is installed, slide the Pole Location Gauge (provided in the instruction packet) between the cleaner pole and the pulley, until it stops at a step (Fig. 7a). Read the flat area where the pole is resting (Fig. 7b). This diameter should be equal to Dim A used in Step 1.

NOTE: If the diameter reading on the Pole Location Gauge does not read the same as in Step 1, check the "C" dimension and correct accordingly.

Test run the cleaner and inspect the performance. If vibration occurs or more cleaning efficiency is desired, make the necessary tensioning adjustments.

Section 5 – Pre-Operation Checklist and Testing

5.1 Pre-Op Checklist

- Recheck that all fasteners are tightened properly
- Add pole caps
- Apply all supplied labels to the cleaner
- Check the blade location on the belt
- Be sure that all installation materials and tools have been removed from the belt and the conveyor area

5.2 Test Run the Conveyor

- Run the conveyor for at least 15 minutes and inspect the cleaning performance
- Check the tensioner spring for recommended length (proper tensioning)
- Make adjustments as necessary

NOTE: Observing the cleaner when it is running and performing properly will help to detect problems or when adjustments are needed later.

Section 6 – Maintenance

Flexco® belt cleaners are designed to operate with minimum maintenance. However, to maintain superior performance some service is required. When the cleaner is installed a regular maintenance program should be set up. This program will ensure that the cleaner operates at optimal efficiency and problems can be identified and fixed before the cleaner stops working.

All safety procedures for inspection of equipment (stationary or operating) must be observed. The EZP1 Precleaner operates at the discharge end of the conveyor and is in direct contact with the moving belt. Only visual observations can be made while the belt is running. Service tasks can be done only with the conveyor stopped and by observing the correct lockout/tagout procedures.

6.1 New Installation Inspection

After the new cleaner has run for a few days a visual inspection should be made to ensure the cleaner is performing properly. Make adjustments as needed.

6.2 Routine Visual Inspection (every 2-4 weeks)

A visual inspection of the cleaner and belt can determine:

- If the spring length is the correct length for optimal tensioning.
- If the belt looks clean or if there are areas that are dirty.
- If the blade is worn out and needs to be replaced.
- If there is damage to the blade or other cleaner components.
- If fugitive material is built up on the cleaner or in the transfer area.
- If there is cover damage to the belt.
- If there is vibration or bouncing of the cleaner on the belt.
- If a snub pulley is used, a check should be made for material buildup on the pulley.

If any of the above conditions exist, a determination should be made on when the conveyor can be stopped for cleaner maintenance.

6.3 Routine Physical Inspection (every 6-8 weeks)

When the conveyor is not in operation and properly locked and tagged out a physical inspection of the cleaner to perform the following tasks:

- Clean material buildup off of the cleaner blade and pole.
- Closely inspect the blade for wear and any damage. Replace if needed.
- Check both blade pins for proper installation and condition. Replace if needed.
- Ensure full blade to belt contact.
- Inspect the cleaner pole for damage.
- Inspect all fasteners for tightness and wear. Tighten or replace as needed.
- Replace any worn or damaged components.
- Check the tension of the cleaner blade to the belt. Adjust the tension if necessary using the chart on the cleaner or the one on Page 10.
- When maintenance tasks are completed, test run the conveyor to ensure the cleaner is performing properly.

Section 6 – Maintenance (cont.)

6.4 Blade Replacement Instructions

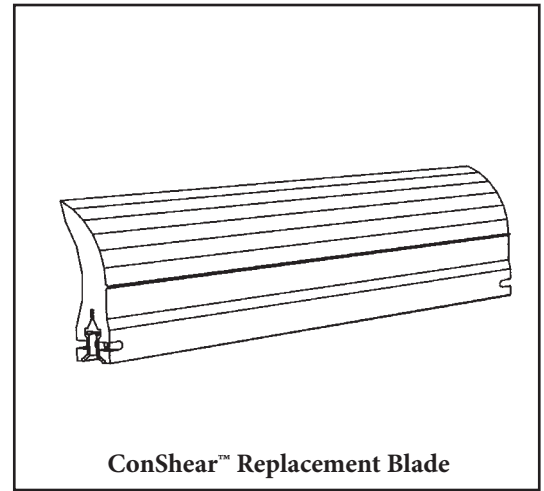
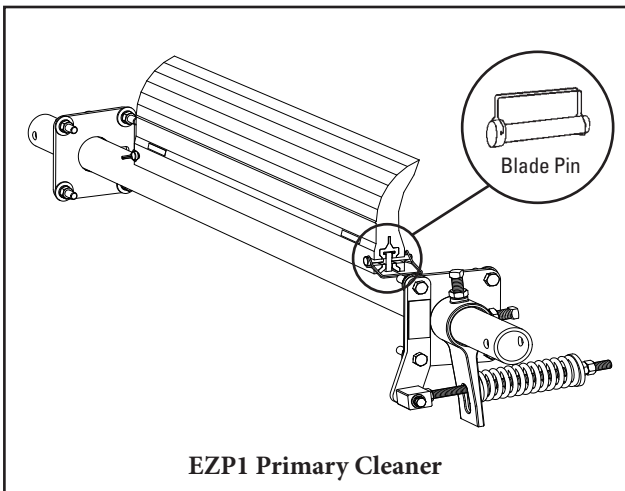

Physically lock out and tag the conveyor at the power source before you begin cleaner installation.

Tools Needed:

- Tape measure
- (2) 38mm spanners or crescent wrenches
- Wire brush (for cleaning pole)
- Small putty knife (for cleaning pole)

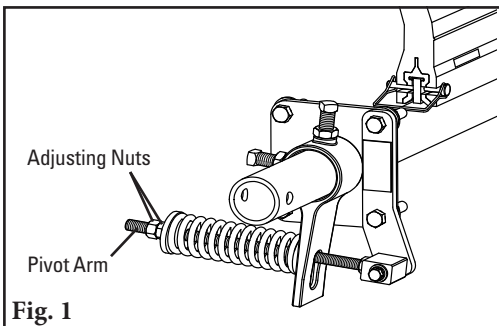

1. **Remove the tension.** Loosen the adjusting nuts on both sides and turn them out until they are flush with ends of the pivot arms (Fig. 1). This releases the tension of the blade on the belt.

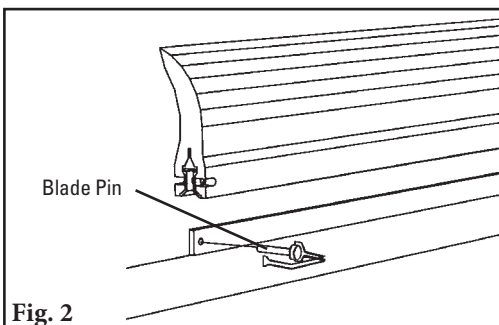

2. **Remove the worn blade.** Remove one blade pin and remove the blade from the pole (Fig. 2). Clean all fugitive material from the pole.

NOTE: If blade is hard to remove use a screwdriver or hammer to loosen it and then remove.

Section 6 – Maintenance (cont.)

6.4 Blade Replacement Instructions

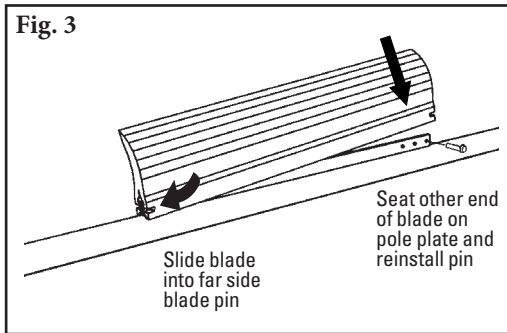

3. **Install the new blade.** Slide the new blade onto the pole, locking it into the far blade pin, then reinstall the removed blade pin, washer and clip (Fig. 3).

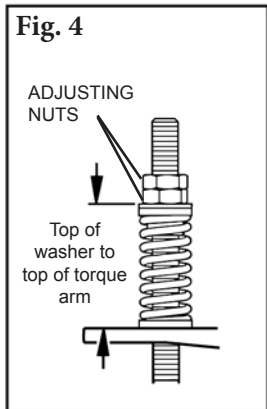

Blade Tension Chart

Blade Width		Purple Springs		Silver Springs		Black Springs	
mm	in.	mm	in.	mm	in.	mm	in.
250	10"	146	5 3/4"	159	6 1/4"	N/A	N/A
400	16"	133	5 1/4"	152	6"	N/A	N/A
550	22"	121	4 3/4"	149	5 7/8"	N/A	N/A
700	28"	108	4 1/4"	143	5 5/8"	N/A	N/A
850	34"	N/A	N/A	137	5 3/8"	143	5 5/8"
1000	40"	N/A	N/A	130	5 1/8"	140	5 1/2"
1150	46"	N/A	N/A	127	5"	133	5 1/4"
1300	52"	N/A	N/A	121	4 3/4"	130	5 1/8"
1450	58"	N/A	N/A	N/A	N/A	127	5"
1600	64"	N/A	N/A	N/A	N/A	121	4 3/4"
1750	70"	N/A	N/A	N/A	N/A	117	4 5/8"

4. **Reset the correct blade tension.** Refer to the chart for the spring length required for the belt width. Lightly pull the pivot arm toward the end of the torque arm slot nearest the pole and turn the adjusting nuts until the required spring length is achieved (Fig. 4).

NOTE: The chart is also on the cleaner's pivot shaft bracket for future reference for retensioning maintenance.

Test run the cleaner. Run the conveyor for at least 15 minutes and inspect the cleaning performance. Check the spring length for proper tensioning. Make adjustments as necessary.

Section 6 – Maintenance (cont.)

6.5 Maintenance Log

Conveyor Name/No. _____

Date: _____ Work done by: _____ Service Quote #: _____

Activity: _____

Date: _____ Work done by: _____ Service Quote #: _____

Activity: _____

Date: _____ Work done by: _____ Service Quote #: _____

Activity: _____

Date: _____ Work done by: _____ Service Quote #: _____

Activity: _____

Date: _____ Work done by: _____ Service Quote #: _____

Activity: _____

Date: _____ Work done by: _____ Service Quote #: _____

Activity: _____

Date: _____ Work done by: _____ Service Quote #: _____

Activity: _____

Date: _____ Work done by: _____ Service Quote #: _____

Activity: _____

Section 6 – Maintenance (cont.)

6.6 Cleaner Maintenance Checklist

Site: _____ Inspected by: _____ Date: _____

Belt Cleaner: _____ Serial Number: _____

Blade Width: Belt minus 50mm (2") Belt minus 200mm (8") Belt minus 350mm (14")

Beltline Information:

Beltline Number: _____ Belt Condition: _____

Belt Width: 450mm (18") 600mm (24") 750mm (30") 900mm (36") 1050mm (42") 1200mm (48") 1350mm (54") 1500mm (60") 1800mm (72")

Head Pulley Diameter (Belt & Lagging): _____ Belt Speed: _____ fpm Belt Thickness: _____

Belt Splice: _____ Condition of Splice: _____ Number of Splices: _____ Skived Unskived

Material conveyed: _____

Days per week run: _____ Hours per day run: _____

Blade Life:

Date blade installed: _____ Date blade inspected: _____ Estimated blade life: _____

Is blade making complete contact with belt? Yes No

Distance from wear line: Left _____ Middle _____ Right _____

Blade condition: Good Grooved Smiled Not contacting belt Damaged

Measurement of spring: Required _____ Currently _____

Was Cleaner Adjusted: Yes No

Pole Condition: Good Bent Worn

Lagging: Side Lag Ceramic Rubber Other None

Condition of lagging: Good Bad Other _____

Cleaner's Overall Performance: (Rate the following 1 - 5, 1 = very poor - 5 = very good)

Appearance: Comments: _____

Location: Comments: _____

Maintenance: Comments: _____

Performance: Comments: _____

Other comments: _____

Section 7 – Troubleshooting

Problem	Possible Cause	Possible Solutions
Poor cleaning performance	Cleaner under-tensioned	Adjust to correct tension – see spring length chart
	Cleaner over-tensioned	Adjust to correct tension – see spring length chart
	Cleaner installed in wrong location	Verify "C" dimension, relocate to correct dimension
	Cleaner blade worn or damaged	Replace cleaner blade
Rapid Blade Wear	Tension on cleaner too high/low	Adjust to correct tension – see spring length chart
	Cleaner not located correctly	Check cleaner location for correct dimensions
	Blade attack angle incorrect	Check cleaner location for correct dimensions
	Material too abrasive for blade	Option: switch to alternate cleaner with metal blades
	Mechanical splice damaging blade	Repair, skive or replace splice
Centre wear on blade (smile effect)	Blade wider than material path	Replace blade with width to match material path
	Tension on cleaner too high/low	Adjust to correct tension – see spring length chart
Unusual wear or damage to blade	Mechanical splice damaging blade	Repair, skive or replace splice
	Belt damaged or ripped	Repair or replace belt
	Cleaner not correctly located	Verify "C" dimension, relocate to correct dimension
	Damage to pulley or pulley lagging	Repair or replace pulley
Vibration or noise	Cleaner not located correctly	Verify "C" dimension, relocate to correct dimension
	Blade attack angle incorrect	Verify "C" dimension, relocate to correct dimension
	Cleaner running on empty belt	Use a spray pole when the belt is empty
	Cleaner tension too high/low	Adjust to correct tension or slight adjust to diminish
	Cleaner locking bolts not secure	Check and tighten all bolts and nuts
	Cleaner not square to head pulley	Verify "C" dimension, relocate to correct dimension
	Material buildup in chute	Clean up build-up on cleaner and in chute
Cleaner being pushed away from pulley	Cleaner tension not set correctly	Ensure correct tension/increase tension slightly
	Sticky material is overburdening cleaner	Increase tension; replace with cleaner with metal tips; replace with larger size cleaner
	Cleaner not set up correctly	Confirm location dimensions are equal on both sides

Section 8 – Specifications and CAD Drawings

Pole Length Specifications

Cleaner Size		Pole Length		Maximum Conveyor Span	
mm	in.	mm	in.	mm	in.
300	12	1050	42	925	37
450	18	1200	48	1075	43
600	24	1350	54	1225	49
750	30	1500	60	1375	55
900	36	1650	66	1525	61
1050	42	1800	72	1675	67
1200	48	1950	78	1825	73
1350	54	2200	88	2075	83
1500	60	2350	94	2225	89
1800	72	2650	106	2525	101

Pole Diameter - 60mm (2-3/8")

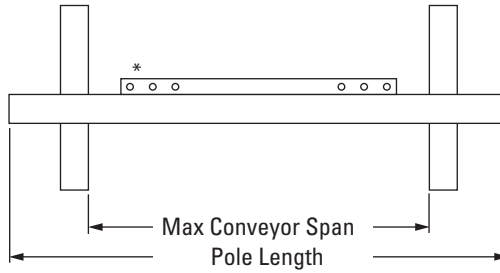

*Each pole size can be used with a blade size either belt width minus 50mm, belt width minus 200mm, or belt width minus 350mm.

Clearance Guidelines For Installation

Horizontal Clearance Required		Vertical Clearance Required	
mm	in.	mm	in.
100	4	238	9 1/2

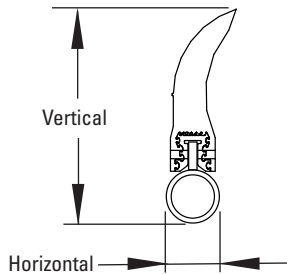

Pole Location Specs

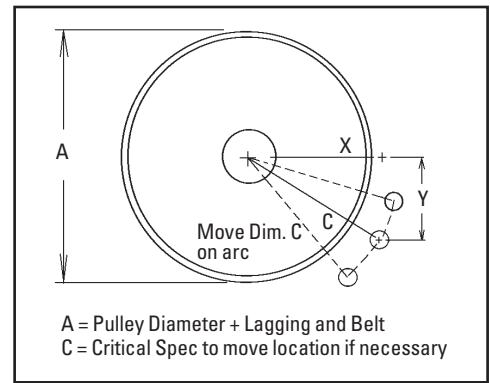

Blade Tension Chart

Blade Width		Purple Springs		Silver Springs		Black Springs	
mm	in.	mm	in.	mm	in.	mm	in.
250	10"	146	5 3/4"	159	6 1/4"	N/A	N/A
400	16"	133	5 1/4"	152	6"	N/A	N/A
550	22"	121	4 3/4"	149	5 7/8"	N/A	N/A
700	28"	108	4 1/4"	143	5 5/8"	N/A	N/A
850	34"	N/A	N/A	137	5 3/8"	143	5 5/8"
1000	40"	N/A	N/A	130	5 1/8"	140	5 1/2"
1150	46"	N/A	N/A	127	5"	133	5 1/4"
1300	52"	N/A	N/A	121	4 3/4"	130	5 1/8"
1450	58"	N/A	N/A	N/A	N/A	127	5"
1600	64"	N/A	N/A	N/A	N/A	121	4 3/4"
1750	70"	N/A	N/A	N/A	N/A	117	4 5/8"

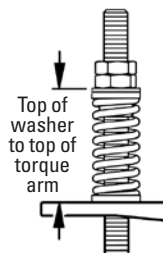

Pole Location Chart

A	X	Y	C
250	74	230	242
275	92	230	248
300	108	230	254
325	131	230	265
350	146	230	273
375	166	230	284
400	179	230	291
425	195	230	301
450	207	230	309
475	223	230	320
500	235	230	329
525	249	230	339
550	266	230	352
575	283	230	365
600	299	230	377
625	314	230	390
650	330	230	402
675	346	230	415
700	360	230	427
725	374	230	439
775	389	230	452
775	403	230	464
825	417	230	477
825	432	230	489
850	446	230	501
875	460	230	514
900	474	230	526

Specifications:

- Maximum Belt Speed.....3.5m/s
- Temperature Rating.....-35°C to 82°C
- Minimum Pulley Diameter250mm
- Blade Height.....185mm
- Usable Blade Wear Length.....100mm
- Blade MaterialPolyurethane (proprietary blend for abrasion resistance and long wear)
- Available for Belt Widths.....300 to 1800mm

Section 8 – Specifications and CAD Drawings (cont.)

8.1 EZP1 - Belt Width Minus 50mm and Minus 200mm

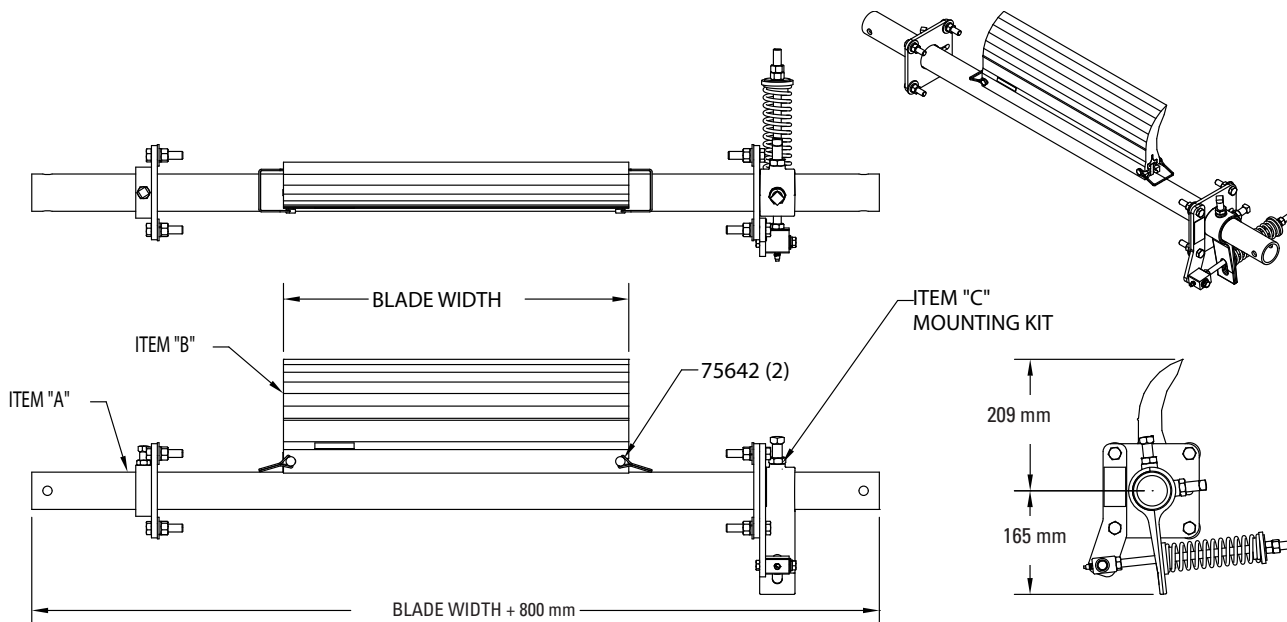

ASSY NUMBER	BLADE WIDTH		ITEM "A"	ITEM "B"	ITEM "C"
	in.	mm.			
75610	10	254	75619	75628	76403
75611	16	406.4	75620	75629	76403
75612	22	558.8	75621	75630	76403
75613	28	711.2	75622	75631	76403
75614	34	863.6	75623	75632	76404
75615	40	1016	75624	75633	76404
75616	46	1168.4	75625	75634	76404
75617	52	1320.8	75626	75635	76404
75618	58	1473.2	75627	75636	76405
75771	70	1778	75619	75773	76405

**EZP1
Belt Width -50mm**

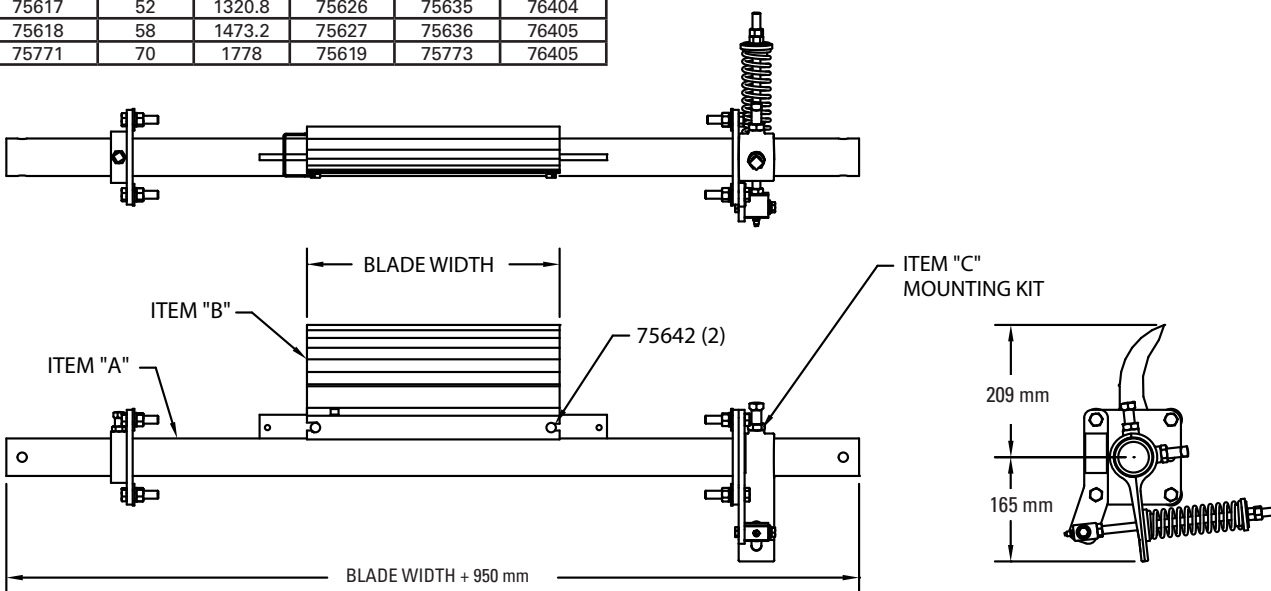

ASSY NUMBER	BLADE WIDTH		ITEM "A"	ITEM "B"	ITEM "C"
	in.	mm.			
75779	10	254	75620	75628	76403
75780	16	406.4	75621	75629	76403
75781	22	558.8	75622	75630	76403
75782	28	711.2	75623	75631	76403
75783	34	863.6	75624	75632	76404
75784	40	1016	75625	75633	76404
75785	46	1168.4	75626	75634	76404
75786	52	1320.8	75627	75635	76404
75774	64	1625.6	75772	75775	76405

**EZP1
Belt Width -200mm**

Section 8 – Specifications and CAD Drawings (cont.)

8.2 EZP1 Hi Temp - Belt Width Minus 50mm (2") and Minus 200mm (8")

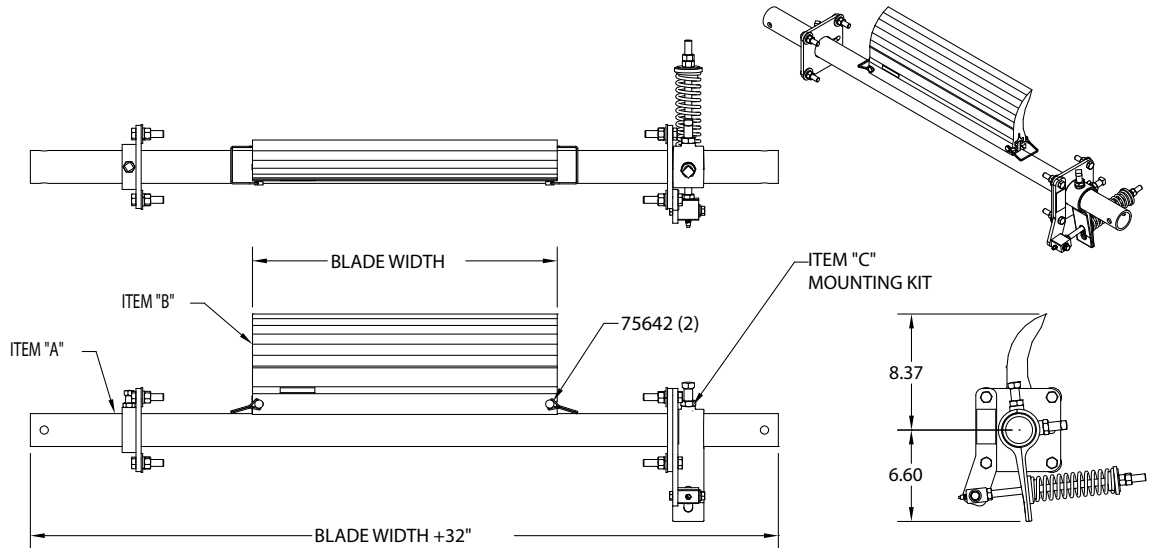

ASSY NUMBER	BLADE WIDTH	ITEM "A"	ITEM "B"	ITEM "C"
76658	10	75619	76593	76403
76659	16	75620	76594	76403
76660	22	75621	76595	76403
76661	28	75622	76596	76403
76662	34	75623	76597	76404
76663	40	75624	76598	76404
76664	46	75625	76599	76404
76665	52	75626	76600	76404
76666	58	75627	76601	76405
76667	70	75772	76603	76405

**EZP1 Hi Temp
Belt Width -50mm (2")**

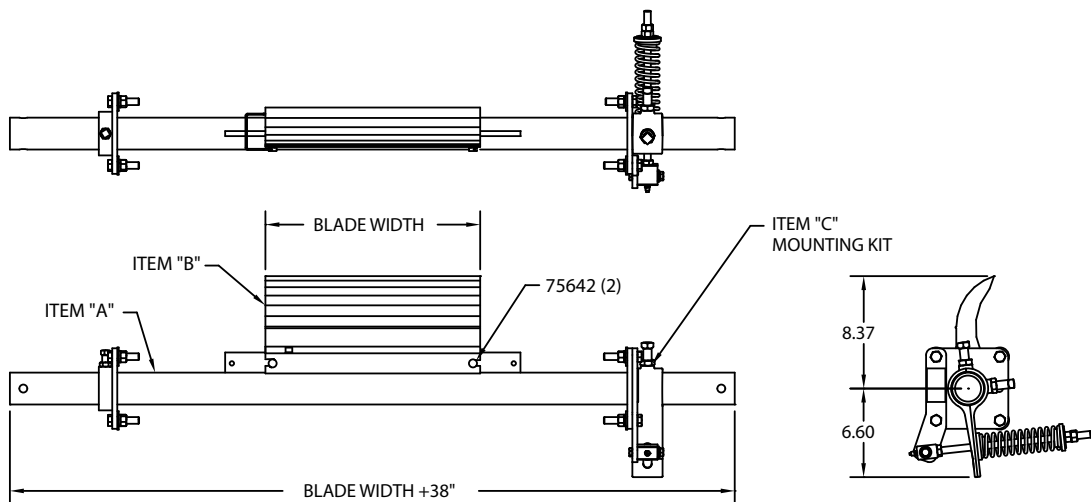

ASSY NUMBER	BLADE WIDTH	ITEM "A"	ITEM "B"	ITEM "C"
90817	10	75620	76593	76403
90818	16	75621	76594	76403
90819	22	75622	76595	76403
90820	28	75623	76596	76403
90821	34	75624	76597	76404
90822	40	75625	76598	76404
90823	46	75626	76599	76404
90824	52	75627	76600	76404
90825	64	75772	76602	76405

**EZP1 Hi Temp
Belt Width -200mm (8")**

Section 9 – Replacement Parts

9.1 EZP1 Powder Coat

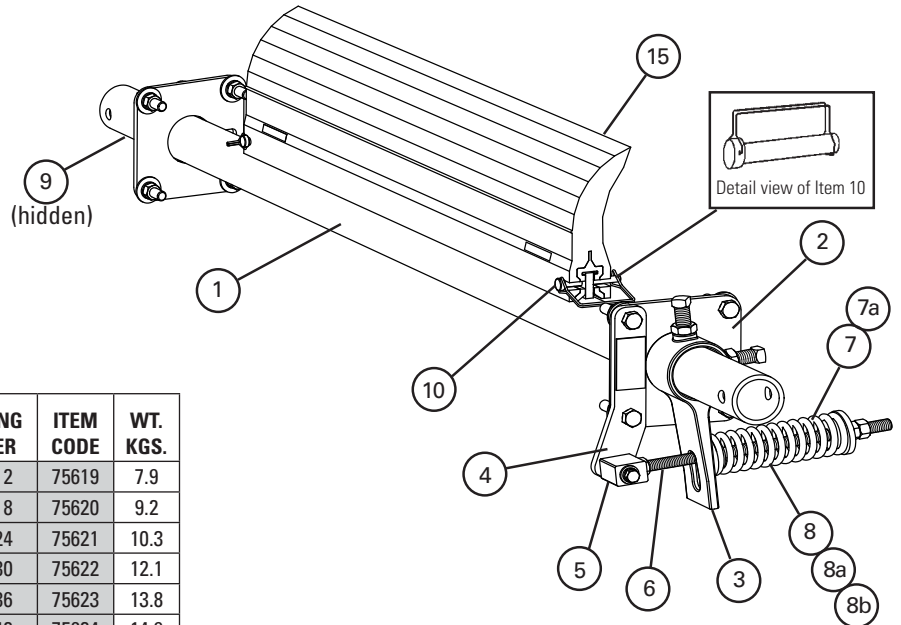

Replacement Parts

REF	DESCRIPTION	ORDERING NUMBER	ITEM CODE	WT. KGS.
1	300 mm Pole	EZP1P12	75619	7.9
	450 mm Pole	EZP1P18	75620	9.2
	600 mm Pole	EZP1P24	75621	10.3
	750 mm Pole	EZP1P30	75622	12.1
	900 mm Pole	EZP1P36	75623	13.8
	1050 mm Pole	EZP1P42	75624	14.9
	1200 mm Pole	EZP1P48	75625	16.1
	1350 mm Pole	EZP1P54	75626	17.8
	1500 mm Pole	EZP1P60	75627	19.7
	1800 mm Pole	EZP1P72	75772	21.9
2	Mounting Plate Kit* (2 ea.)	EZP1MPK	75637	3.5
3	Torque Arm Kit* (1 ea.)	ESTAK	76406	1.6
4	Pivot Shaft Bracket Kit* (1 ea.)	ESPSBK	76407	0.8
5	Pivot Block Kit*	ESPBK	76408	0.3
6	Pivot Rod Kit*	ESPRK	76409	0.6
7	Bushing Kit - Purple and Silver (includes 2 bushings)	ESBK-PS	76410	0.1
7a	Bushing Kit - Black (includes 2 bushings)	ESBK-B	76411	0.1
8	Tension Spring - Purple	QMTS-P	75845	0.5
8a	Tension Spring - Silver	ESS-S	76412	0.6
8b	Tension Spring - Black	ESS-B	76413	0.6
9	Pole Lock* (1 ea.)	EZP1PL	75641	0.5
-	EST Tensioner - Purple* for blade widths 300 - 700 mm (includes 1 each items 3, 4, 5, 6, 7 & 8)	EST-P	76403	3.5
-	EST Tensioner - Silver* for blade widths 850 - 1300 mm (includes 1 each items 3, 4, 5, 6, 7 & 8a)	EST-S	76404	3.6
-	EST Tensioner - Black* for blade widths 1450 - 1750 mm (includes 1 each items 3, 4, 5, 6, 7a & 8b)	EST-B	76405	3.7
10	Blade Pin (1 ea.)	EZP1BP	75642	0.1

*Hardware Included

Spring Tensioner Selection Chart

CLEANER BLADE WIDTH	76403 EST-P	76404 EST-S	76405 EST-B
ConShear 300 - 700 mm	X		
ConShear 850 - 1300 mm		X	
ConShear 1450 - 1750 mm			X

Section 9 – Replacement Parts

9.2 EZP1 Stainless Steel

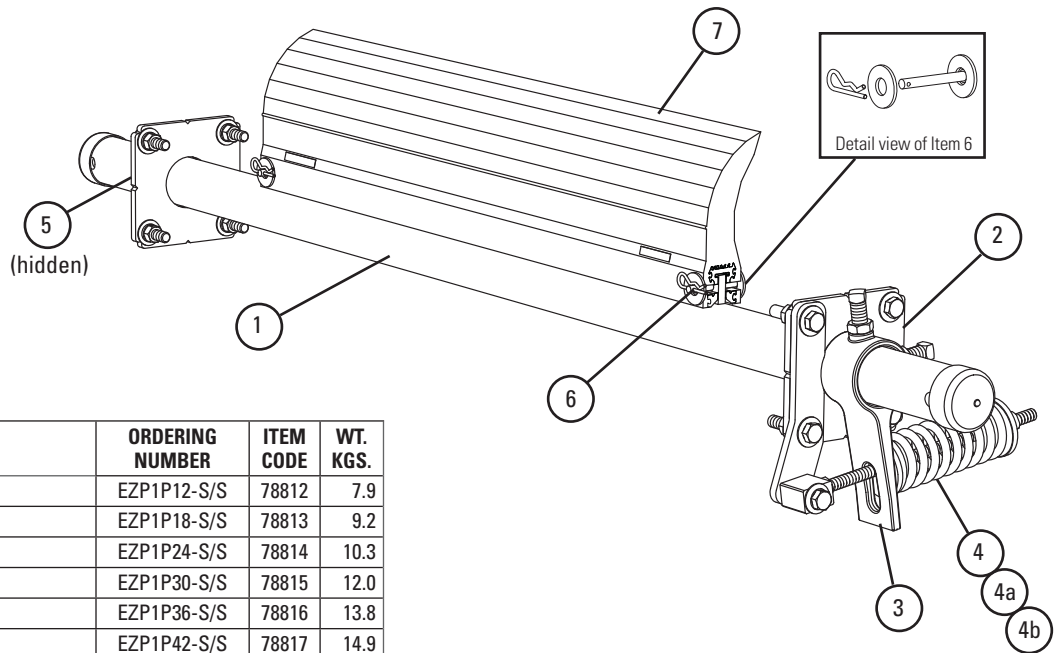

Replacement Parts

REF	DESCRIPTION	ORDERING NUMBER	ITEM CODE	WT. KGS.
1	300 mm S/S Pole	EZP1P12-S/S	78812	7.9
	450 mm S/S Pole	EZP1P18-S/S	78813	9.2
	600 mm S/S Pole	EZP1P24-S/S	78814	10.3
	750 mm S/S Pole	EZP1P30-S/S	78815	12.0
	900 mm S/S Pole	EZP1P36-S/S	78816	13.8
	1050 mm S/S Pole	EZP1P42-S/S	78817	14.9
	1200 mm S/S Pole	EZP1P48-S/S	78818	16.0
	1350 mm S/S Pole	EZP1P54-S/S	78819	17.8
	1500 mm S/S Pole	EZP1P60-S/S	78820	19.7
	1800 mm S/S Pole	EZP1P72-S/S	78821	21.9
2	SS Mounting Plate Kit* (2 ea.)	EZP1MPK-S/S	78923	3.5
3	SS Torque Arm Kit* (1 ea.)	ESTAK-EST-S/S	78849	1.6
4	SS Tension Spring - Purple	QMTS-P-S/S	77450	0.5
4a	SS Tension Spring - White	QMTS-W-S/S	77451	0.5
4b	SS Tension Spring - Gold	QMTS-G-S/S	77452	0.6
5	SS Pole Lock* (1 ea.)	EZP1PL-S/S	78848	0.5
-	SS EST Tensioner - Purple* for blade widths 12" - 28" (300 - 700mm) (includes 1 each items 2, 3, 4)	EST-P-S/S	78808	3.5
-	SS EST Tensioner - White* for blade widths 34" - 52" (850 - 1300mm) (includes 1 each items 2, 3, 4a)	EST-W-S/S	78809	3.6
-	SS EST Tensioner - Gold* for blade widths 58" - 70" (1450 - 1750mm) (includes 1 each items 2, 3, 4b)	EST-G-S/S	78810	3.7
6	Blade Pin (1 ea.)	MSPBPK-S/S	77583	0.0

*Hardware Included
Lead time: 1 working day

Spring Tensioner Selection Chart

CLEANER BLADE WIDTH	78808 EST-P-S/S	78809 EST-W-S/S	78810 EST-G-S/S
ConShear 300 - 700 mm	X		
ConShear 850 - 1300 mm		X	
ConShear 1450 - 1750 mm			X

Section 10 – Other Flexco Conveyor Products

Flexco provides many conveyor products that help your conveyors to run more efficiently and safely. These components solve typical conveyor problems and improve productivity. Here is a quick overview on just a few of them:

MSP Precleaner



- Patented ConShear™ blade renews its cleaning edge as it wears
- Visual Tension Check™ for optimal blade tensioning and simple retensioning
- Quick and easy one-pin blade replacement Material Path Option™ for optimal cleaning and reduced maintenance

DRX™ Impact Beds



- Exclusive Velocity Reduction Technology™ to better protect the belt
- Slide-Out Service™ gives direct access to all impact bars for change-out
- Impact bar supports for longer bar life
- 4 models to custom fit to the application

EZS2 Secondary Cleaner



- Long-wearing tungsten carbide blades for superior cleaning efficiency
- Patented FormFlex™ cushions independently tension each blade to the belt for consistent, constant cleaning power
- Easy to install, simple to service
- Works with Flexco® mechanical belt splices

PT Max™ Belt Trainer



- Patented “pivot & tilt” design for superior training action
- Dual sensor rollers on each side to minimize belt damage
- Pivot point guaranteed not to freeze up
- Available for topside and return side belts

Flexco Specialty Belt Cleaners



- “Limited space” cleaners for tight conveyor applications
- High Temp cleaners for severe, high heat applications
- A rubber-fingered cleaner for chevron and raised-rib belts
- Multiple cleaner styles in stainless steel for corrosive applications

Belt Plows



- A belt cleaner for the tail pulley
- Exclusive blade design quickly spirals debris off the belt
- Economical and easy to service
- Available in vee or diagonal models

The Flexco Vision

To become the leader in maximising
belt conveyor productivity for our customers worldwide
through superior service and innovation.

Flexco (Aust.) Pty. Ltd • 10 Solent Circuit, Norwest • NSW, Australia, 2153 • Australia
Tel: 612-8818-2000 • Fax: 612-8824-6333 • E-mail: salesau@flexco.com

Visit www.flexco.com for other Flexco locations and products.

©2020 Flexible Steel Lacing Company. 08/18/20. For reorder: X3036

