

MMP Stainless Medium-Duty Precleaner

Extra Cleaning Power for Corrosive Environments

The MMP Stainless Steel Medium-Duty Precleaner tackles those tough applications where the standard-duty precleaner is not sturdy enough but the heavy-duty cleaner is overkill. The MMP is built tough with a stainless steel heavy-duty pole and beefy dual tensioning system, and a larger, powerful blade. Yet installation is simple, maintenance is quick, and bottom line—the cleaning job is excellent.

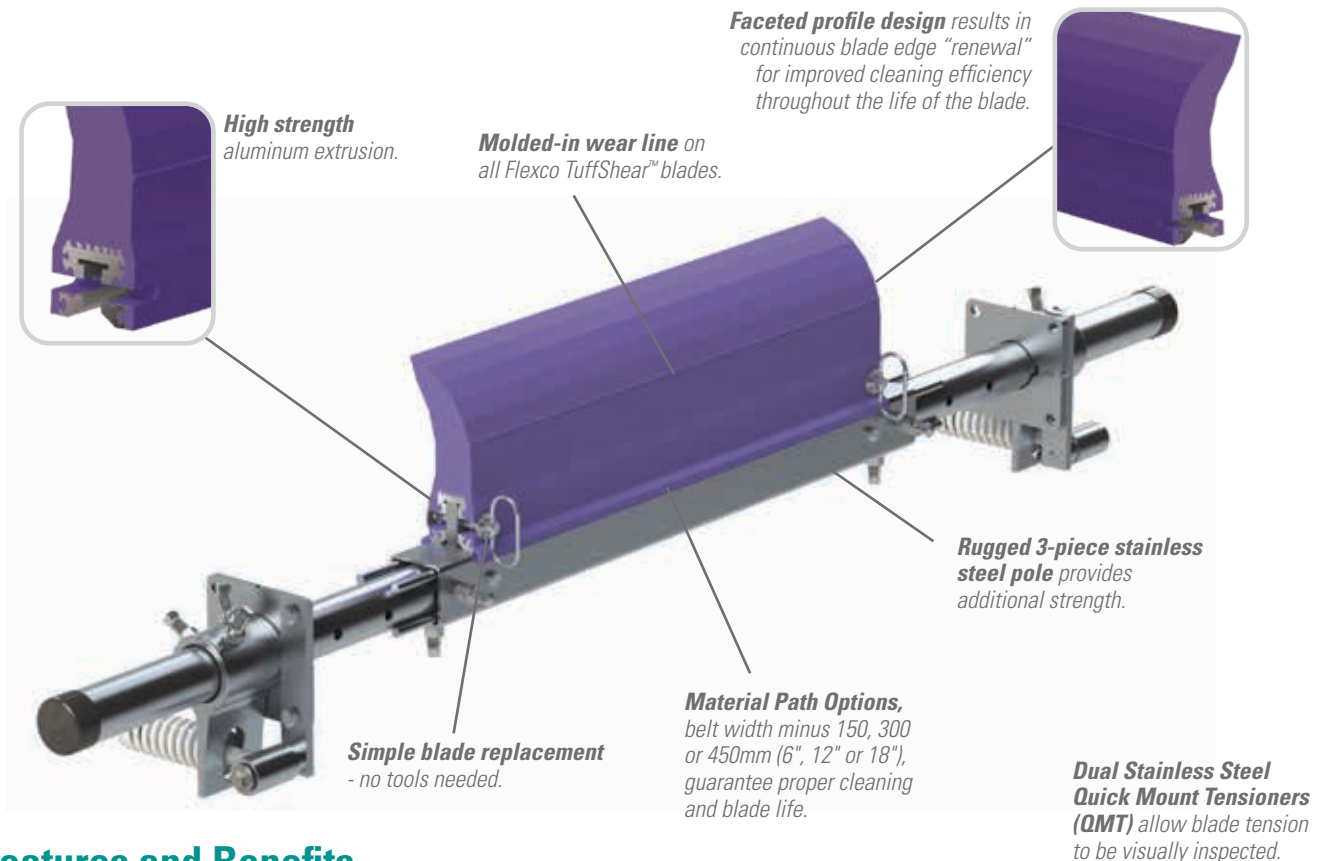

Features and Benefits

- **Stainless steel.** Corrosive environments wear on any component, but stainless steel can protect against that.
- **Compact and versatile.** Requires only 100mm (4") of horizontal clearance for installation. Pole length is belt width plus 1350mm (54") to fit varying conveyor or chute wall widths. Pole extenders are available for extended length requirements.
- **Works with Flexco and other mechanical splices.** The spring tensioner quickly moves the blade away from the belt when a splice passes. The polyurethane blade easily glides over the splice without damage and with minimal cleaning disruption.
- **Made for mining conveyors.** Made from heavy-duty stainless steel, the MMP is available for belt widths from 600 to 2100mm (24" to 84"). Special sizes are available upon request.
- **Complete cleaning system.** When teamed with our MHS Secondary Cleaner, it makes up a system that delivers maximum cleaning power. If extra water is present, the MDWS DryWipe can be added.



MMP Stainless

Medium-Duty Precleaner

Specifications and Guidelines

- **Maximum Belt Speed**
5 m/s (1000 FPM)
- **Temperature Rating**
-35°C to 82°C (-30°F to 180°F)
- **Minimum Pulley Diameter**
400 mm (16")
- **Blade Height**
250 mm (10")
- **Useable Blade Wear Length**
150 mm (6")
- **Blade Material**
Urethane 83 durometer (proprietary blend for abrasion resistance and long wear)
- **Available for Belt Widths**
600 to 2100mm (24" to 84")
- **Horizontal Clearance Required**
100mm (4")
- **Vertical Clearance Required**
325mm (13")
- **Pole Length**
Cleaner size + 1350mm (54")
- **Maximum Conveyor Span**
Cleaner size + 1050mm (42")

Pole Location Specs

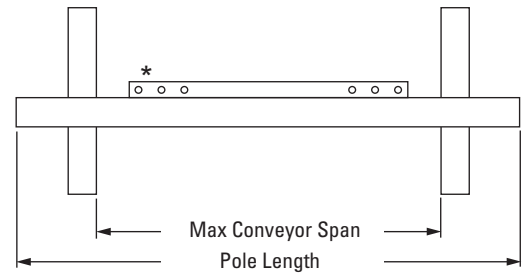
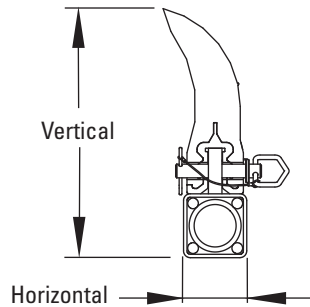
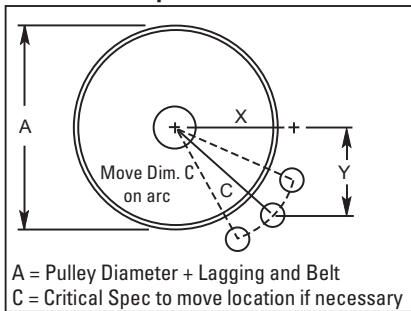

Pole Location Chart

A	X	Y	C	A	X	Y	C	A	X	Y	C
400	204	305	367	675	353	305	467	950	496	305	582
425	218	305	375	700	366	305	476	975	508	305	592
450	231	305	383	725	380	305	487	1000	521	305	604
475	244	305	390	775	392	305	497	1025	533	305	614
500	259	305	400	775	403	305	506	1050	550	305	629
525	274	305	410	825	417	305	517	1075	569	305	646
550	288	305	419	825	432	305	528	1100	584	305	659
575	300	305	428	850	444	305	539	1125	601	305	674
600	315	305	438	875	457	305	549	1150	615	305	686
625	328	305	448	900	469	305	559	1175	632	305	702
650	341	305	457	925	483	305	571	1200	645	305	714

Ordering Information

MMP SS Precleaners - Belt Width Minus 150mm					
Belt Width		Blade Coverage		Ordering Number	Item Code
mm	in.	mm	in.		
600	24	450	18	MMP-624-S/S	77424
750	30	600	24	MMP-630-S/S	77425
900	36	750	30	MMP-636-S/S	77426
1050	42	900	36	MMP-642-S/S	77427
1200	48	1050	42	MMP-648-S/S	77428
1350	54	1200	48	MMP-654-S/S	77429
1500	60	1350	54	MMP-660-S/S	77430
1800	72	1650	66	MMP-672-S/S	77431
2100	84	1950	78	MMP-684-S/S	77432

MMP SS Precleaners - Belt Width Minus 300mm					
Belt Width		Blade Coverage		Ordering Number	Item Code
mm	in.	mm	in.		
750	30	450	18	MMP-1230-S/S	77433
900	36	600	24	MMP-1236-S/S	77434
1050	42	750	30	MMP-1242-S/S	77435
1200	48	900	36	MMP-1248-S/S	77436
1350	54	1050	42	MMP-1254-S/S	77437
1500	60	1200	48	MMP-1260-S/S	77438
1800	72	1500	60	MMP-1272-S/S	77439
2100	84	1800	72	MMP-1284-S/S	77440

TuffShear™ Replacement Blades			
Blade Width		Ordering Number	Item Code
mm	in.		
450	18	TRB18	76485
600	24	TRB24	76486
750	30	TRB30	76487
900	36	TRB36	76488
1050	42	TRB42	76489
1200	48	TRB48	76490
1350	54	TRB54	76491
1500	60	TRB60	76492
1650	66	TRB66	76493
1800	72	TRB72	76494
1950	78	TRB78	76697

Lead time: 1 working day

Shaded items are made to order.
Lead time: 3 weeks

Authorized Distributor:

New Door No. 51 • Anna Salai, Nagalkeni • Pammal Village • Chennai - 600 044 • Tamil Nadu • India
Tel: +91-44-4856-6762 • E-mail: info.india@flexco.com

Visit www.flexco.com for other Flexco locations and products.

©2020 Flexible Steel Lacing Company. 01/15/20. For reorder: X2959

