

# MDWS Heavy-Duty Secondary Belt Cleaner

## The Final Step in Belt Cleaning

Many times the belt cleaners on a beltline do a good job of taking off the carryback materials. However, after the last cleaner, there is still water on the belt and that can still cause a big mess along the beltline. The MDWS Secondary Belt Cleaner is designed to be the last cleaner in a cleaning system and wipe the belt dry.

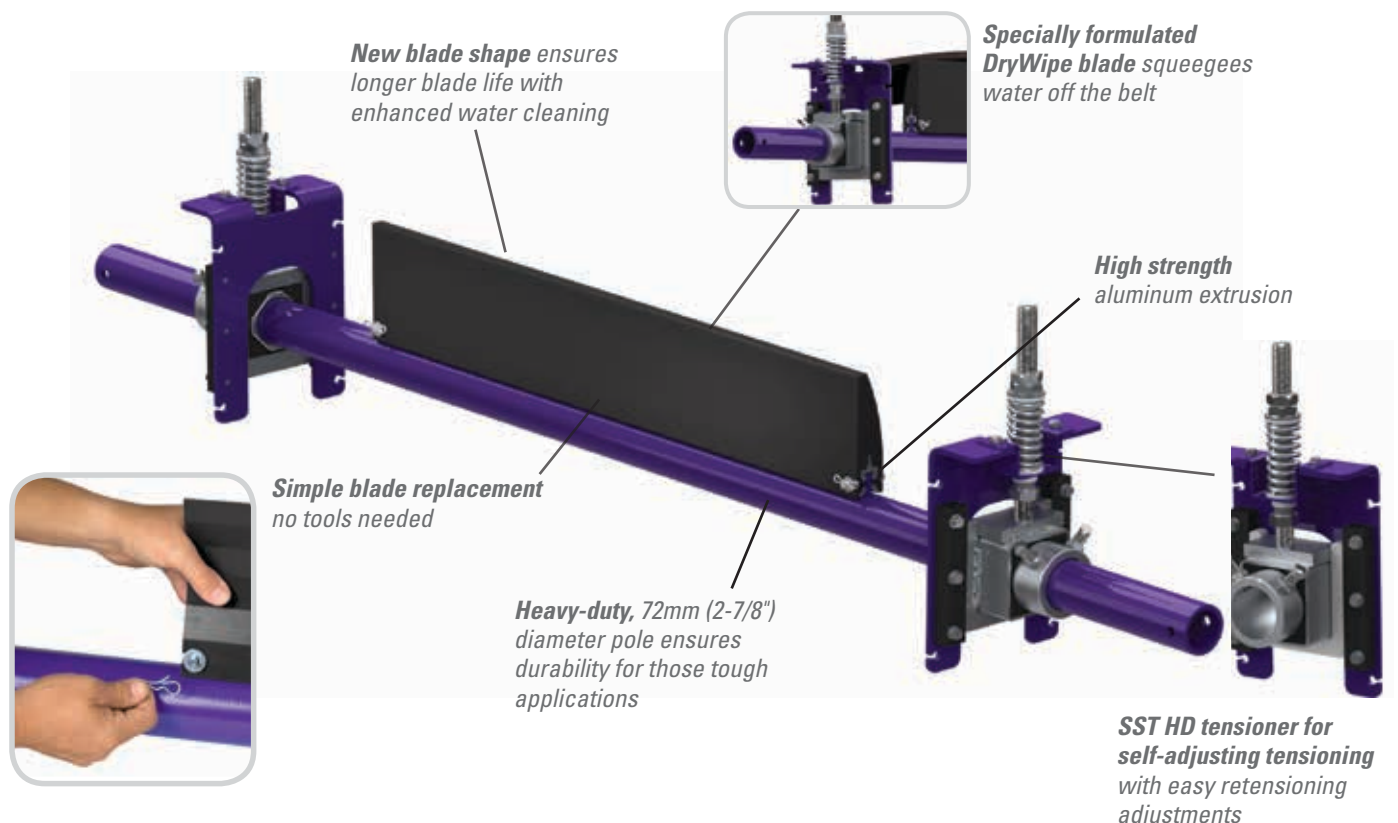

### Features and Benefits

- **Long wear life.** Blade has 113mm (4-1/2") of usable urethane.
- **Low maintenance.** Occasionally check for blade wear and measure springs for proper tensioning.
- **Works with mechanical fasteners.** The polyurethane blade easily glides over the mechanical splices and the spring tensioners dampen any impact, allowing the splices to pass without damage to the blade or the splice and with minimal cleaning disruption.
- **Streamlined design.** The MDWS has minimal horizontal surfaces for carryback to build up on. Carryback buildup often renders other secondary cleaners ineffective.
- **Complete cleaning system.** When teamed with a Minline precleaner and one or more secondary cleaners depending upon the application, the MDWS is the unbeatable final cleaner in a cleaning system that delivers unmatched cleaning performance and efficiency.
- **Made for mining conveyors.** The MDWS comes standard with an extra-long pole (belt width plus 1500mm (60") for cleaners up to 1500mm (60") and belt width plus 1350mm (54") for cleaners over 1500mm (60"), so it can be used on most mining conveyors. It is available for belt widths from 600 to 2400mm (24" to 96").

# MDWS Heavy-Duty Secondary Belt Cleaner

## Specifications and Guidelines

### Maximum Belt Speed

5 M/sec (1000 FPM)

### Temperature Rating

-35° C to 82° C (-30° F to 180° F)

### Blade Height

185mm (7-1/4")

### Usable Blade Wear Length

113mm (4-1/2")

### Blade Material

Urethane 59 durometer (softer to squeegee water off)

### Available for Belt Widths

600 to 2100mm (24" to 84")

**Pole Length** Cleaner size up to 1500mm (60") + 1500mm (60")

**Maximum Conveyor Span** Cleaner size over 1500mm (60") + 1350mm (54")

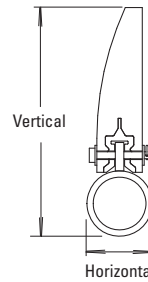
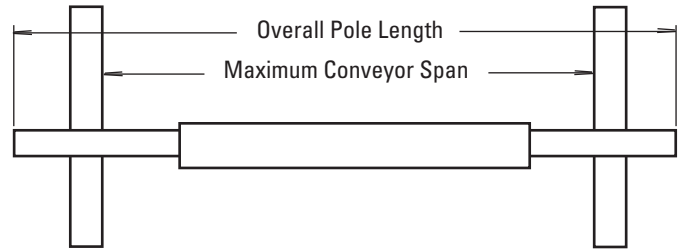

**Horizontal Clearance Required**  
100mm (4")

**Vertical Clearance Required**  
250mm (10")

## Ordering Information

Ordering Information					
MDWS DryWipe Belt Cleaners					
Belt Width		Blade Coverage		Item Code	Ordering Number
mm	in.	mm	in.		
600	24	700	28	75868	MDWS-24
750	30	850	34	75869	MDWS-30
900	36	1000	40	75870	MDWS-36
1050	42	1150	46	75871	MDWS-42
1200	48	1300	52	75872	MDWS-48
1350	54	1450	58	75873	MDWS-54
1500	60	1600	64	75874	MDWS-60
1800	72	1900	76	75875	MDWS-72
2100	84	2200	88	76806	MDWS-84
2400	96	2500	100	79063	MDWS-96

Ordering Information			
ConShear™ DW Replacement Blades			
Belt Width		Item Code	Ordering Number
mm	in.		
600	24	75884	CDWB24
750	30	75885	CDWB30
900	36	75886	CDWB36
1050	42	75887	CDWB42
1200	48	75888	CDWB48
1350	54	75889	CDWB54
1500	60	75890	CDWB60
1800	72	75891	CDWB72
2100	84	76942	CDWB84
2400	96	79062	CDWB96

## Additional Information

Use in combination with a precleaner and secondary cleaner for the most effective cleaning solution.



Authorized Distributor:

2 Woodlands Sector 1 • #01-21 • Woodlands Spectrum I • Singapore 738068  
Tel: +65-6484-1533 • Fax: +65-6484-1531 • E-mail: [asiasales@flexco.com](mailto:asiasales@flexco.com)

Visit [www.flexco.com](http://www.flexco.com) for other Flexco locations and products.

©2015 Flexible Steel Lacing Company. 09/15. For reorder: X2804

