

R-TYPE® Secondary Belt Cleaner

Reversing Secondary Belt Cleaner

The Flexco R-Type® Secondary Belt Cleaner is recommended for reversing belts and is designed to be positioned just off the head pulley to remove carryback from the belt. Stand alone, or when used in conjunction with a precleaner, the R-Type cleaner is a reliable choice for maintaining a highly efficient cleaning system.

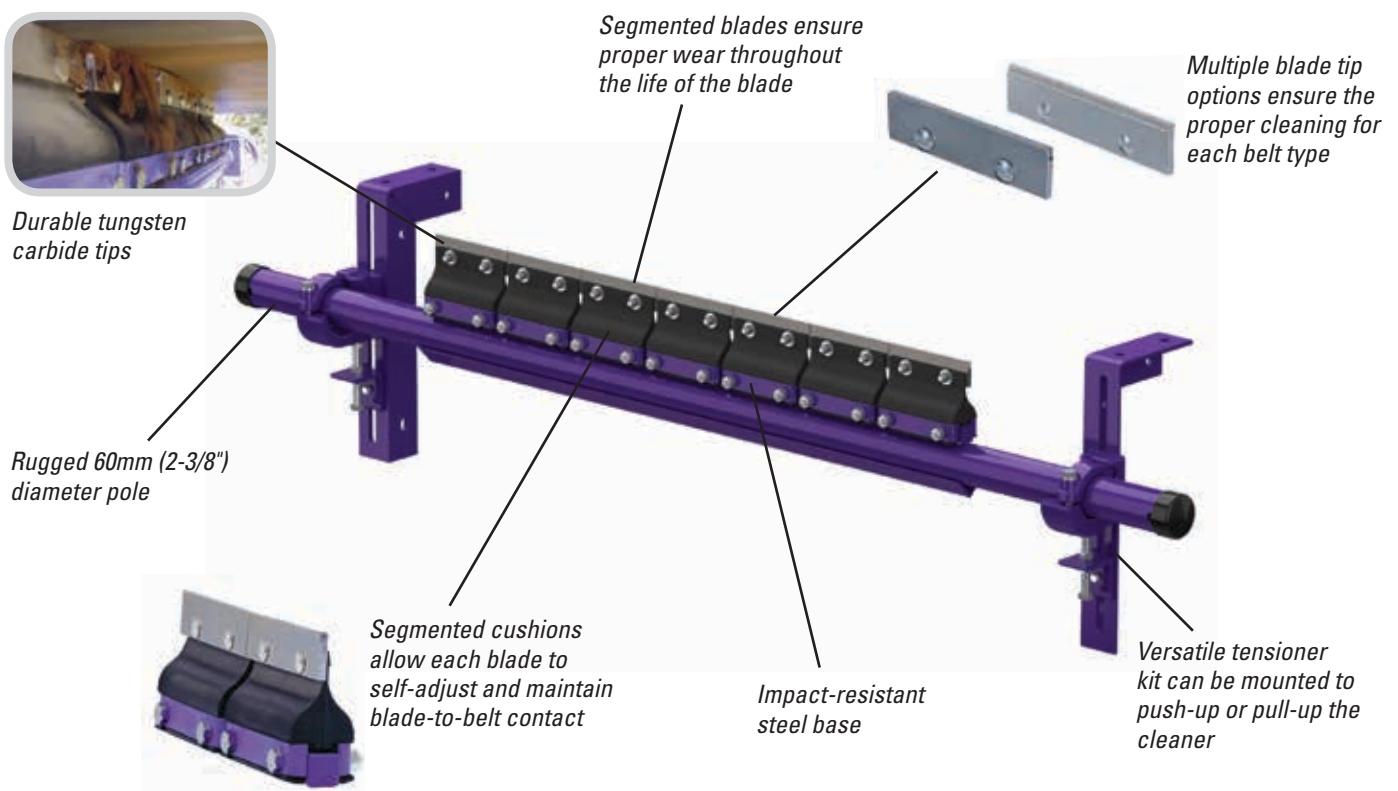

Features and Benefits

- **Cleaning efficiency of metal blades.** The thin, hard edges of the metal blades deliver high cleaning efficiency and long wear life.
- **Works with Flexco mechanical splices.** The C-Tip tungsten carbide blades are impact-resistant, and the spring cushion allows them to move away from a passing splice without damage and with minimal cleaning disruption. V-Tips can be used only on vulcanized belts.
- **A complete cleaning system.** When the R-Type is teamed with a precleaner the system provides maximum cleaning power for tough applications.
- **Fits most conveyor structures.** Available for belt widths from 450 mm to 1800 mm (18" to 72").

R-TYPE® Secondary Belt Cleaner

Specifications and Guidelines

Maximum Belt Speed

5 M/sec (1000 FPM)

Temperature Rating

-35° C to 82° C F (-30° F to 180°)

Usable Blade Wear Length

9mm (3/8")

Blade Material

Impact resistant, long-lasting tungsten carbide (C-Tips for mechanical fasteners, V-Tips for vulcanized belts)

Available for Belt Widths

450 to 1800mm (18" to 72")

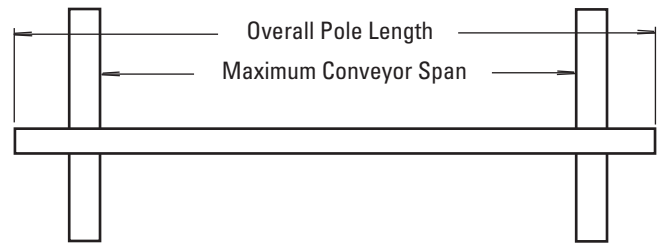

Pole Length

Cleaner size up to 1200mm (48") + 750mm (30")

Cleaner size 1350mm (54") and up + 850mm (34")

Maximum Conveyor Span

Cleaner size up to 1200mm (48") + 625mm (25")

Cleaner size 1350mm (54") and up + 725mm (29")

Horizontal Clearance Required

100mm (4")

Vertical Clearance Required

200mm (8")

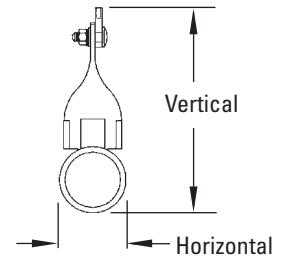

Ordering Information

R-Type® Reversing with C-Tips*			
Belt Width		Ordering Number	Item Code
mm	in.		
450	18	RC450	81367
600	24	RC600	81368
750	30	RC750	81369
900	36	RC900	81370
1050	42	RC1050	81371
1200	48	RC1200	81372
1350	54	RC1350	81373
1500	60	RC1500	81374
1800	72	RC1800	81375

*NOTE: C-Tips can be used on mechanically spliced and vulcanized belts.

R-Type Reversing with V-Tips*			
Belt Width		Ordering Number	Item Code
mm	in.		
450	18	RV450	74633
600	24	RV600	73634
750	30	RV750	74635
900	36	RV900	74636
1050	42	RV1050	74637
1200	48	RV1200	74638
1350	54	RV1350	74639
1500	60	RV1500	74640
1800	72	RV1800	74642

*NOTE: V-Tips can be used ONLY on vulcanized belts.

Replacement Tips	
Ordering Number	Item Code
RSA150	76249
ICT6	74535

Lead time: 1 working day

Tips Required per Cleaner Size									
mm	450	600	750	900	1050	1200	1350	1500	1800
in.	18	24	30	36	42	48	54	60	72
C-Tips or V-Tips Required	3	4	5	6	7	8	9	10	12

Authorized Distributor:

2 Woodlands Sector 1 • #01-21 • Woodlands Spectrum I • Singapore 738068

Tel: +65-6484-1533 • Fax: +65-6484-1531 • E-mail: asiasales@flexco.com

Visit www.flexco.com for other Flexco locations and products.

©2015 Flexible Steel Lacing Company. 05/15. For reorder: X2803

