

HIGH TEMP EZS2 Secondary Cleaner

The Economical, Efficient Belt Cleaning Solution

The High Temp EZS2 Secondary Belt Cleaner improves belt cleaning efficiency and reduces routine maintenance tasks in environments up to 204° C (400° F) or spikes up to 232° C (450° F). And it does all of this at an affordable price. Add easy, do-it-yourself installation and it makes an unbeatable solution for your conveyor belt cleaning needs.

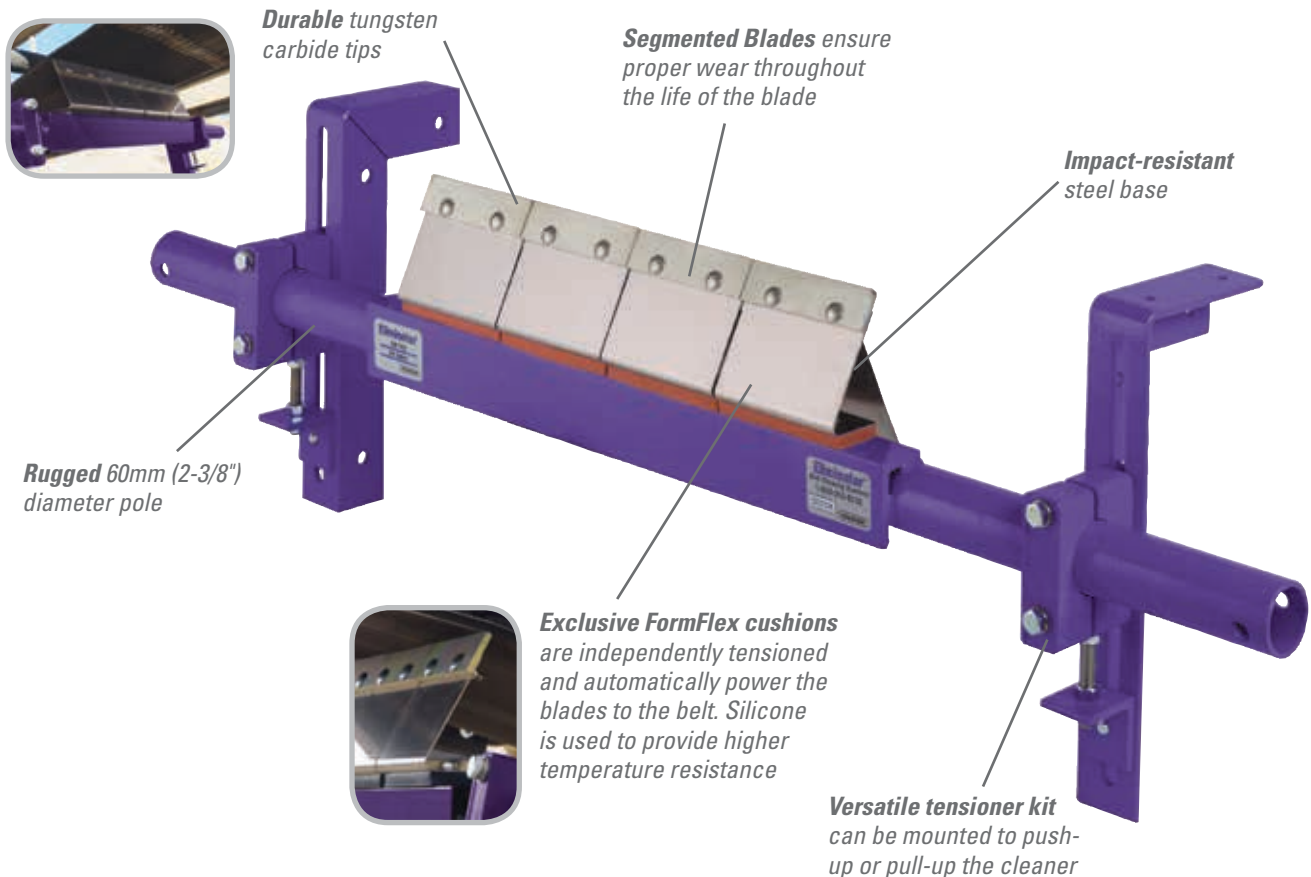

Features and Benefits

- **Cleaning efficiency of metal blades.** The thin, hard edges of the metal blades deliver high cleaning efficiency and long wear life.
- **Works with Flexco mechanical splices.** The tungsten carbide-tipped blades are impact-resistant, and the spring cushion allows them to move away from a passing splice without damage and with minimal cleaning disruption.
- **A complete cleaning system.** When the High Temp EZS2 is teamed with the High Temp EZP1, the system proves maximum cleaning power for tough high temperature applications.
- **Fits most conveyor structures.** Available for belt widths from 450mm to 1800mm (18" to 72").

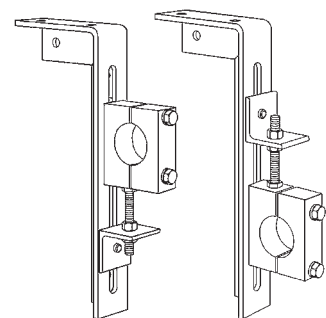

HIGH TEMP EZS2

Secondary Cleaner

Specifications and Guidelines

- **Maximum Belt Speed**
3.5M/sec (700 FPM)
- **Max Temperature Rating**
-35° C to 204° C F (-30° F to 400°)

- **Pole Length**
Blade width + 850mm (34")
- **Maximum Conveyor Span**
Blade width + 725mm (29")

- **Blade Material**
Impact Resistant Tungsten Carbide (works with mechanical fasteners)
- **Usable Blade Wear Length**
9mm (3/8")

- **Available for Belt Widths**
450 to 1800mm (18" to 72")
- **Horizontal Clearance Required**
100mm (4")
- **Vertical Clearance Required**
213 to 238mm (8-1/2 to 9-1/2")

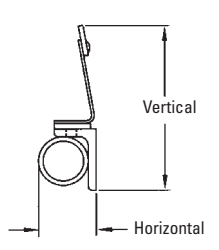
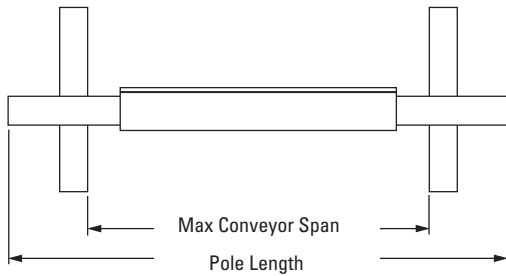

Ordering Information

High Temp Secondary Cleaner with C-Tips			
Belt Width		Ordering Number	Item Code
mm	in.		
450	18	HTS18	76085
600	24	HTS24	76086
750	30	HTS30	76087
900	36	HTS36	76088
1050	42	HTS42	76089
1200	48	HTS48	76090
1350	54	HTS54	76091
1500	60	HTS60	76092
1800	72	HTS72	76093

Pole Diameter - 60mm (2-3/8")
Lead time: 1 working day

Replacement C-Tips	
Ordering Number	Item Code
ICT6	74535

Lead time: 1 working day

Replacement Cushion Kit	
Ordering Number	Item Code
HTSCK	76094

Lead time: 1 working day

Tips Required per Cleaner Size									
mm	450	600	750	900	1050	1200	1350	1500	1800
in.	18	24	30	36	42	48	54	60	72
C-Tips Required	3	4	5	6	7	8	9	10	12

Additional Information

For standard applications, see the EZS2 Sell Sheet.



Authorized Distributor:

2 Woodlands Sector 1 • #01-21 • Woodlands Spectrum I • Singapore 738068
Tel: +65-6484-1533 • Fax: +65-6484-1531 • E-mail: asiasales@flexco.com

Visit www.flexco.com for other Flexco locations and products.

©2015 Flexible Steel Lacing Company. 09/15. For reorder: X2800

