

U-TYPE® Secondary Cleaner

Superior Cleaning Power

The U-Type® Secondary Belt Cleaner is designed for constant blade-to-belt contact for the highest cleaning efficiency – especially in tough applications requiring removal of water and sticky carryback materials. The U-shaped design conforms to the belt, allowing the tungsten carbide tips to shear stubborn carryback materials from the belt. No straight-blade cleaner has both the cleaning and shearing action necessary to provide the cleaning power needed in wet and sticky material applications.

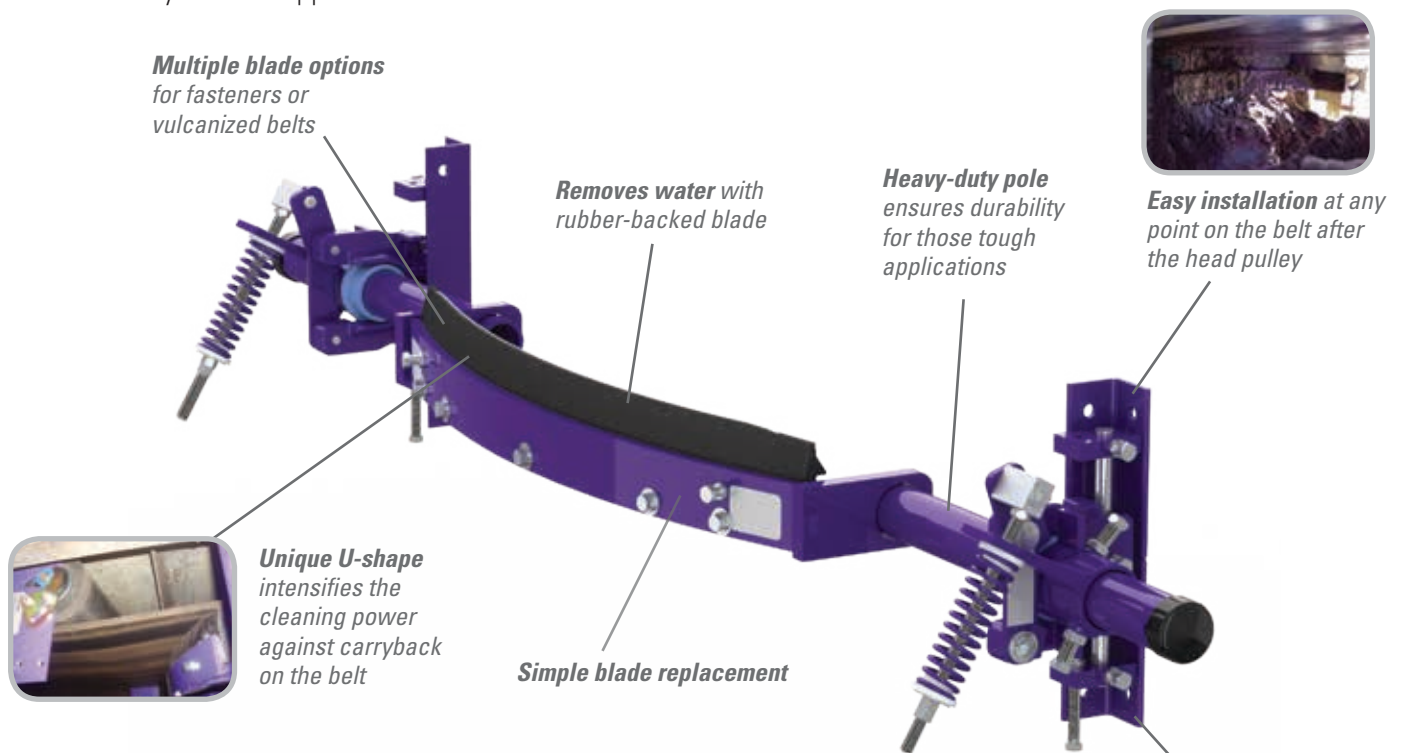

Features and Benefits

- **Works with mechanical splices.** The impact-resistant C-Blade allows Flexco® Solid Plate fasteners and rip repairs to easily glide over the blade without recessing the splice. The V-Blade works only on mechanical splices that are skived into the belt. An F-Blade (urethane) is available for use on all types of Flexco splices. All blade types can be used on vulcanized splices.
- **Blade replacement made easy with removable plate.** Simply release the blade tension, loosen the bolts on the back of the cleaner pole, slide the worn blade out, insert the new blade and retighten the bolts. The job can be done in minutes.
- **The final cleaner in a cleaning system.** The U-Type is unbeatable as the final cleaner in a complete cleaning system. Teamed with a precleaner and in some cases another secondary cleaner, the results are unmatched in cleaning efficiency. Flexco can design a system to meet your specific requirements.
- **Locking Collar on tensioner allows for easy blade-to-belt setup.**



U-TYPE® Secondary Cleaner

Specifications and Guidelines

Maximum Belt Speed

V-Blade & C-Blade: 6.6 m/s (1300 FPM)

F-Blade: 5 m/s (1000 FPM)

Temperature Rating

-35° C to 82° C (-30° F to 180° F)

Usable Blade Wear Length

V-Blade & C-Blade: 9mm (3/8")

F-Blade: 44mm (1-3/4")

Available for Belt Widths

450 to 2100mm (18" to 84")

Blade Material

V-Blade & C-Blade: Tungsten-Carbide with Rubber Backer

F-Blade: Urethane 90 durometer

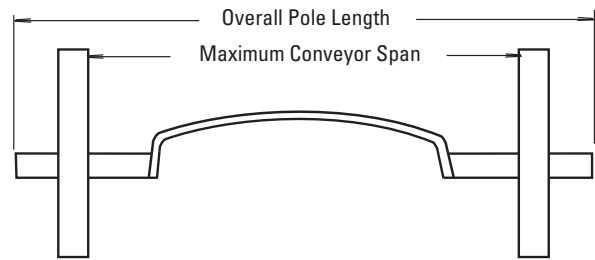

Pole Length

Cleaner size up to 1500mm (60") + 1150mm (46")

Cleaner size 1800mm and up (72") + 1300mm (52")

Maximum Conveyor Span

Cleaner size up to 1500mm (60") + 900mm (36")

Cleaner size 1800mm and up (72") + 1050mm (42")

Clearance Guidelines for Installation							
U Cleaner Size		Clearance		U Cleaner Size		Clearance	
mm	in.	mm	in.	mm	in.	mm	in.
450	18"	140	5 1/2	1350	54"	242	9 1/2
600	24"	166	6 1/2	1500	60"	242	9 1/2
750	30"	191	7 1/2	1800	72"	261	10 1/4
900	36"	171	7 1/2	2100	84"	261	10 1/4
1050	42"	217	8 1/2	2400	96"	261	10 1/4
1200	48"	242	9 1/2				

Horizontal Clearance Required

See Chart Below

Vertical Clearance Required

250mm (5")

Clearance Requirement Specs

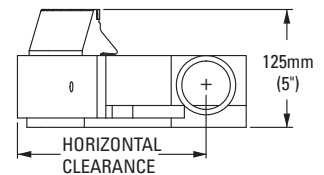

Ordering Information

U-Type with V-Blade (Tungsten Carbide)*					
Cleaner Complete			Replacement V-Blade		
Belt Width	Ordering	Item	Ordering	Item	
mm	in.	Number	Number	Code	Code
450	18	UTV18	76700	URVB18/450	76736
600	24	UTV24	76701	URVB24/600	76737
750	30	UTV30	76702	URVB30/750	76738
900	36	UTV36	76703	URVB36/900	76739
1050	42	UTV42	76704	URVB42/1050	76740
1200	48	UTV48	76705	URVB48/1200	76741
1350	54	UTV54	76706	URVB54/1350	76742
1500	60	UTV60	76707	URVB60/1500	76743
1800	72	UTV72	76708	URVB72/1800	76744
2100	84	UTV84	76709	URVB84/2100	76745
2400	96	UTV96	79238	URVB96/2400	76746

*NOTE: V-Blades (Tungsten Carbide) can be used on vulcanized belts and mechanically spliced belts ONLY IF the splice is skived (recessed into the belt's cover) (on solid plate splices the bolts must be ground). CAUTION: The V-Blade CANNOT be used on belts with mechanical repair fasteners. Use the F-Blade.

U-Type with C-Blade (Impact-Resistant Tungsten Carbide)*					
Cleaner Complete			Replacement C-Blade		
Belt Width	Ordering	Item	Ordering	Item	
mm	in.	Number	Number	Code	Code
450	18	UTC18	76712	URCB18/450	76748
600	24	UTC24	76713	URCB24/600	76749
750	30	UTC30	76714	URCB30/750	76750
900	36	UTC36	76715	URCB36/900	76751
1050	42	UTC42	76716	URCB42/1050	76752
1200	48	UTC48	76717	URCB48/1200	76753
1350	54	UTC54	76718	URCB54/1350	76754
1500	60	UTC60	76719	URCB60/1500	76755
1800	72	UTC72	76720	URCB72/1800	76756
2100	84	UTC84	76721	URCB84/2100	76757
2400	96	UTC96	79239	URCB96/2400	76758

*NOTE: C-Blades can be used on Flexco® Solid Plate, mechanically fastened and vulcanized belts.

U-Type with F-Blade (Urethane)*					
Cleaner Complete			Replacement F-Blade		
Belt Width	Ordering	Item	Ordering	Item	
mm	in.	Number	Number	Code	Code
450	18	UTF18	76724	UFB18	74448
600	24	UTF24	76725	UFB24	74449
750	30	UTF30	76726	UFB30	74450
900	36	UTF36	76727	UFB36	74451
1050	42	UTF42	76728	UFB42	74452
1200	48	UTF48	76729	UFB48	74453
1350	54	UTF54	76730	UFB54	74454
1500	60	UTF60	76731	UFB60	74455
1800	72	UTF72	76732	UFB72	74456
2100	84	UTF84	76733	UFB84	74460
2400	96	UTF96	79240	UFB96	74461

*NOTE: F-Blades (Urethane) can be used on mechanically spliced belts and vulcanized belts.

Authorized Distributor:

240 Macpherson Road • #02-01 • Singapore 348574
Tel: +65-6484-1533 • Fax: +65-6484-1531 • E-mail: asiasales@flexco.com

Visit www.flexco.com for other Flexco locations and products.

©2019 Flexible Steel Lacing Company. 07/31/19. For reorder: X2623

