

MSP

Standard Mine-Duty Precleaner

Economical and Effective

The MSP Standard-Duty Precleaner is not your average solid-blade belt cleaner that mounts on the head pulley. It is a mine-tough design that combines simple, do-it-yourself installation, quick maintenance and effective cleaning results with an affordable price tag.

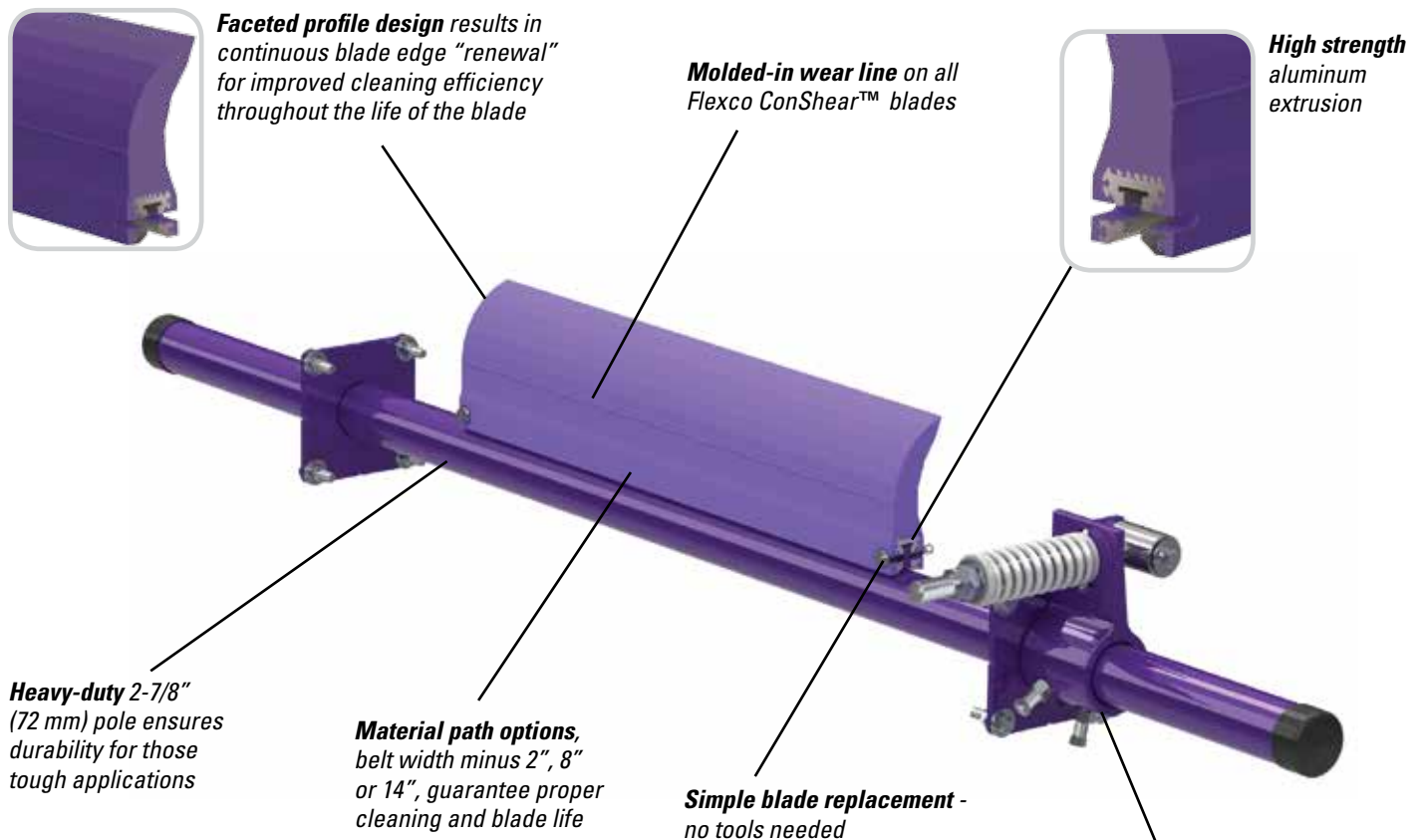

Features and Benefits

- **Quick-change blade.** No tools are needed. Just pull one pin, remove the old blade, slide in the new one and replace the pin.
- **Works with Flexco and other mechanical splices.** The spring tensioner quickly moves the blade away from the belt when a splice passes. The polyurethane blade easily glides over the splice without damage and with minimal cleaning disruption.
- **Easy to service.** All maintenance work is done from the easy-access side of the beltline. Blade retensioning and change-out are quick and easy.
- **Fits most conveyor structures.** Available for belt widths from 24" to 84" (600 to 2100mm). The MSP poles are extra long (belt width plus 54"/1350 mm) to accommodate varying structure widths.

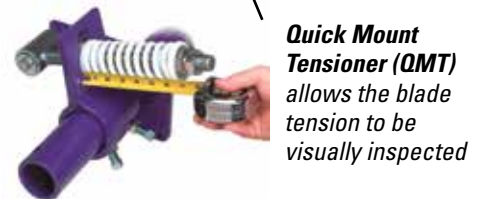

MSP

Standard Mine-Duty Precleaner

Specifications and Guidelines

- Maximum Belt Speed**
700 FPM (3.5 M/sec)
- Temperature Rating**
-30°F to 180°F (-35°C to 82°C)
- Minimum Pulley Diameter**
16" (400mm)
- Blade Height**
7-1/4" (185mm)
- Usable Blade Wear Length**
4" (100mm)
- Blade Material**
Urethane 83 durometer (proprietary blend for abrasion resistance and long wear)
- Available for Belt Widths**
24" to 84" (600 to 2100mm)
- CEMA Cleaner Rating**
Class 3
- Horizontal Clearance Required**
4" (100mm)
- Vertical Clearance Required**
10" (254mm)
- Pole Length**
Cleaner size + 54" (1350mm)
- Maximum Conveyor Span**
Cleaner size + 44" (1100mm)

Pole Location Specs

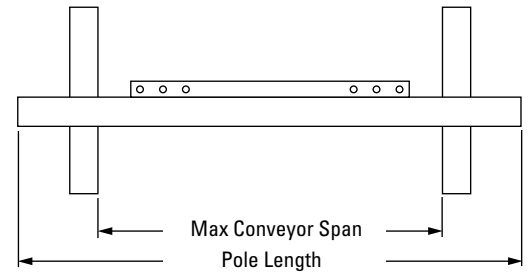
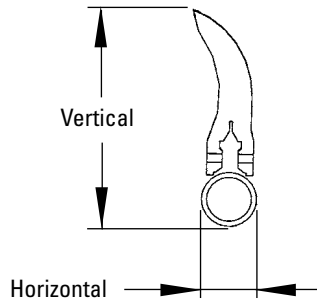
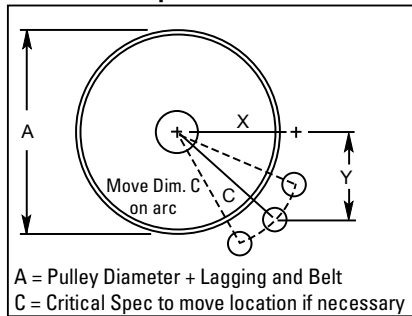

Pole Location Chart

A	X	Y	C	A	X	Y	C	A	X	Y	C
16"	7-1/8"	9"	11-1/2"	25"	12-5/8"	9"	15-1/2"	34"	17-7/8"	9"	20"
17"	7-7/8"	9"	12"	26"	13-1/4"	9"	16"	35"	18-3/8"	9"	20-1/2"
18"	8-1/4"	9"	12-1/4"	27"	13-7/8"	9"	16-1/2"	36"	19"	9"	21"
19"	9"	9"	12-3/4"	28"	14-3/8"	9"	17"	37"	19-1/2"	9"	21-1/2"
20"	9-3/8"	9"	13"	29"	15"	9"	17-1/2"	38"	20"	9"	22"
21"	10"	9"	13-1/2"	30"	15-5/8"	9"	18"	39"	20-5/8"	9"	22-1/2"
22"	10-3/4"	9"	14"	31"	16-1/8"	9"	18-1/2"	40"	21-1/8"	9"	23"
23"	11-3/8"	9"	14-1/2"	32"	16-3/4"	9"	19"	41"	21-3/4"	9"	23-1/2"
24"	12"	9"	15"	33"	17-1/4"	9"	19-1/2"	42"	22-1/4"	9"	24"

Ordering Information

MSP Standard-Duty Precleaner Belt Width Minus 2"					
Belt Width		Blade Width		Ordering Number	Item Code
in.	mm	in.	mm		
24	600	22	550	MSP-224	75787
30	750	28	700	MSP-230	75788
36	900	34	850	MSP-236	75789
42	1050	40	1000	MSP-242	75790
48	1200	46	1150	MSP-248	75791
54	1350	52	1300	MSP-254	75792
60	1500	58	1450	MSP-260	75793
72	1800	70	1750	MSP-272	75794
84	2100	82	2050	MSP-284	76796

MSP Standard-Duty Precleaner Belt Width Minus 8"					
Belt Width		Blade Width		Ordering Number	Item Code
in.	mm	in.	mm		
24	600	16	400	MSP-824	75795
30	750	22	550	MSP-830	75796
36	900	28	700	MSP-836	75797
42	1050	34	850	MSP-842	75798
48	1200	40	1000	MSP-848	75799
54	1350	46	1150	MSP-854	75800
60	1500	52	1300	MSP-860	75801
72	1800	64	1600	MSP-872	75802
84	2100	76	1900	MSP-884	76797

Replacement ConShear™ Blades			
Blade Width		Ordering Number	Item Code
in.	mm		
16	300	CRB-16	75629
22	350	CRB-22	75630
28	450	CRB-28	75631
34	600	CRB-34	75632
40	750	CRB-40	75633
46	800	CRB-46	75634
52	950	CRB-52	75635
58	1000	CRB-58	75636
64	1150	CRB-64	75775
70	1200	CRB-70	75773
76	1350	CRB-76	76940
82	1400	CRB-84	76941

Other blade sizes available upon request.

Authorized Distributor:



2525 Wisconsin Avenue • Downers Grove, IL 60515-4200 • USA
Tel: (630) 971-0150 • Fax: (630) 971-1180 • E-mail: info@flexco.com

Visit www.flexco.com for other Flexco locations and products.

