

H-Type[®] High-Temp Precleaner with V-Tips

Installation, Operation and Maintenance Manual



H-Type® High Temp Precleaner with V-Tips

Serial Number: _____
Purchase Date: _____
Purchased From: _____
Installation Date: _____

Serial number information can be found on the Serial Number Label included in the Information Packet found in the cleaner carton.

This information will be helpful for any future inquiries or questions about belt cleaner replacement parts, specifications or troubleshooting.

Table of Contents

Section 1 – Important Information	2
1.1 General Introduction	2
1.2 User Benefits	2
1.3 Service Option	2
Section 2 – Safety Considerations and Precautions	3
2.1 Stationary Conveyors.....	3
2.2 Operating Conveyors	3
Section 3 – Pre-Installation Checks and Options.....	4
3.1 Checklist	4
3.2 Cleaner Location Adjustments	5
Section 4 – Installation Instructions.....	6
4.1 Installation Instructions.....	6
4.2 Shimming Instructions	13
Section 5 – Cleaner Pole Location Charts	14
5.1 Pole Location Charts.....	14
Section 6 – Pre-Operation Checklist and Testing.....	16
6.1 Pre-Op Checklist	16
6.2 Test Run the Conveyor.....	16
Section 7 – Maintenance	17
7.1 New Installation Inspection	17
7.2 Routine Visual Inspection	17
7.3 Routine Physical Inspection.....	17
7.4 Blade Replacement Instructions.....	18
7.5 Maintenance Log	20
7.6 Cleaner Maintenance Checklist.....	21
Section 8 – Troubleshooting	22
Section 9 – Specs and CAD Drawings.....	23
9.1 Specifications and Guidelines	23
9.2 CAD Drawings.....	24
Section 10 – Replacement Parts List	27
Section 11 – Other Flexco® Conveyor Products.....	28

Section 1 – Important Information

1.1 General Introduction

We at Flexco are very pleased that you have selected an H-Type® High Temp Precleaner with V-Tips for your conveyor system.

This manual will help you to understand the operation of this product and assist you in making it work up to its maximum efficiency over its lifetime of service.

It is essential for safe and efficient operation that the information and guidelines presented be properly understood and implemented. This manual will provide safety precautions, installation instructions, maintenance procedures and troubleshooting tips.

If, however, you have any questions or problems that are not covered, please visit our web site or contact our Customer Service Department:

Customer Service: 1-800-541-8028

Visit www.flexco.com for other Flexco locations and products.

Please read this manual thoroughly and pass it on to any others who will be directly responsible for installation, operation and maintenance of this cleaner. While we have tried to make the installation and service tasks as easy and simple as possible, **it does however require correct installation and regular inspections and adjustments to maintain top working condition.**

1.2 User Benefits

Correct installation and regular maintenance will provide the following benefits for your operation:

- Reduced conveyor downtime
- Reduced man-hour labor
- Lower maintenance budget costs
- Increased service life for the belt cleaner and other conveyor components

1.3 Service Option

The H-Type High Temp Precleaner with V-Tips is designed to be easily installed and serviced by your on-site personnel. However, if you would prefer complete turn-key factory service, please contact your local Flexco Field Representative.

Section 2 – Safety Considerations and Precautions

Before installing and operating the H-Type® High Temp Precleaner with V-Tips, it is important to review and understand the following safety information.

There are set-up, maintenance and operational activities involving both **stationary** and **operating** conveyors. Each case has a safety protocol.

2.1 Stationary Conveyors

The following activities are performed on stationary conveyors:

- Installation
- Blade replacement
- Repairs
- Tension adjustments
- Cleaning

DANGER

It is imperative that OSHA/MSHA Lockout/Tagout (LOTO) regulations, 9 CFR 1910.147, be followed before undertaking the preceding activities. Failure to use LOTO exposes workers to uncontrolled behavior of the belt cleaner caused by movement of the conveyor belt. Severe injury or death can result.

Before working:

- Lockout/Tagout the conveyor power source
- Disengage any takeups
- Clear the conveyor belt or clamp securely in place

WARNING

Use Personal Protective Equipment (PPE):

- Safety eyewear
- Hardhats
- Safety footwear

Close quarters, springs and heavy components create a worksite that compromises a worker's eyes, feet and skull.

PPE must be worn to control the foreseeable hazards associated with conveyor belt cleaners. Serious injuries can be avoided.

2.2 Operating Conveyors

There are two routine tasks that must be performed while the conveyor is running:

- Inspection of the cleaning performance
- Dynamic troubleshooting

DANGER

Every belt cleaner is an in-running nip hazard. Never touch or prod an operating cleaner. Cleaner hazards cause instantaneous amputation and entrapment.

WARNING

Belt cleaners can become projectile hazards. Stay as far from the cleaner as practical and use safety eyewear and headgear. Missiles can inflict serious injury.

WARNING

Never adjust anything on an operating cleaner. Unforeseeable belt projections and tears can catch on cleaners and cause violent movements of the cleaner structure. Flailing hardware can cause serious injury or death.

Section 3 – Pre-installation Checks and Options

3.1 Checklist

- Check that the cleaner size is correct for the beltline width
- Check the belt cleaner carton and make sure all the parts are included
- Review the “Tools Needed” list on the top of the installation instructions
- Check the conveyor site:
 - Will the cleaner be installed on a chute
 - Is the install on an open head pulley requiring mounting structure
 - Are there obstructions that may require cleaner location adjustments

Section 3 - Pre-Installation Checks and Options (cont.)

3.2 Cleaner Location Adjustments

In certain applications it is necessary to modify the location of the precleaner pole due to permanent obstacles that obstruct the desired location. Relocating the pole location can be done easily and does not hinder the performance of the cleaner as long as the “C” dimension is maintained.

NOTE: In the following example we will be lowering the pole location in the “Y” direction, but the same method could also be applied in the “X” direction.

Conveyor situation:

Pulley Diameter: 24"

X = 7-3/4"

Y = 12"

C = 14-1/4"

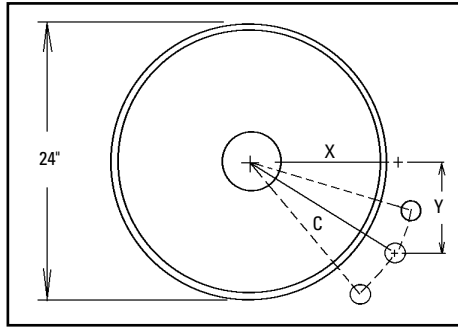

- Determine the given location dimensions and define the change needed.** After laying out the given X & Y dimensions, determine the distance of the modification required for adequate clearance of the pole and tensioning system. (In the example we decide to lower the pole 2" to clear the support structure).
- Write down known dimensions.** We can now determine two of the three required dimensions which will allow us to find the third. We know we cannot alter the “C” dimension, so this will remain the same. Also we are required to lower the unit in the “Y” dimension 2", so we add 2" to the given “Y” dimension.

X = ?"

Y = 12 + 2 = 14"

C = 14-1/4"

- Determine final dimension.** On a flat vertical surface, using a level, draw one horizontal line and one vertical line creating a right triangle (Fig 3a). Measure down from the intersection the determined “Y” dimension and mark (Fig 3b). With the tape measure starting at the modified “Y” mark, swing the tape across the “X” line and mark at the “C” dimension where it crosses the “X” line (Fig 3c). Measure from the intersection to the “C” intersection and this will be your new “X” dimension (Fig 3d).

X = 2-5/8"

Y = 14"

C = 14-1/4"

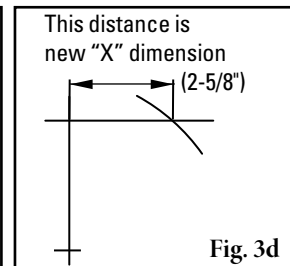
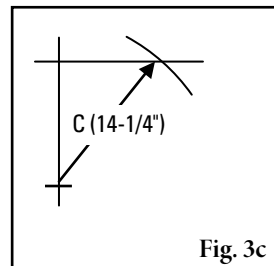
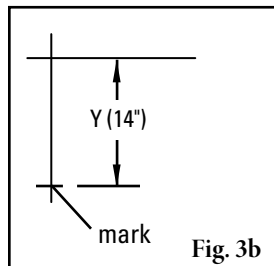
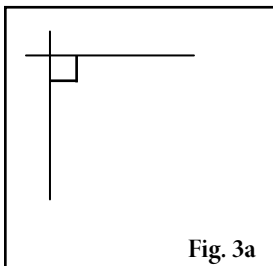

Section 4 – Installation Instructions

4.1 H-Type® High Temp Precleaner with V-Tips

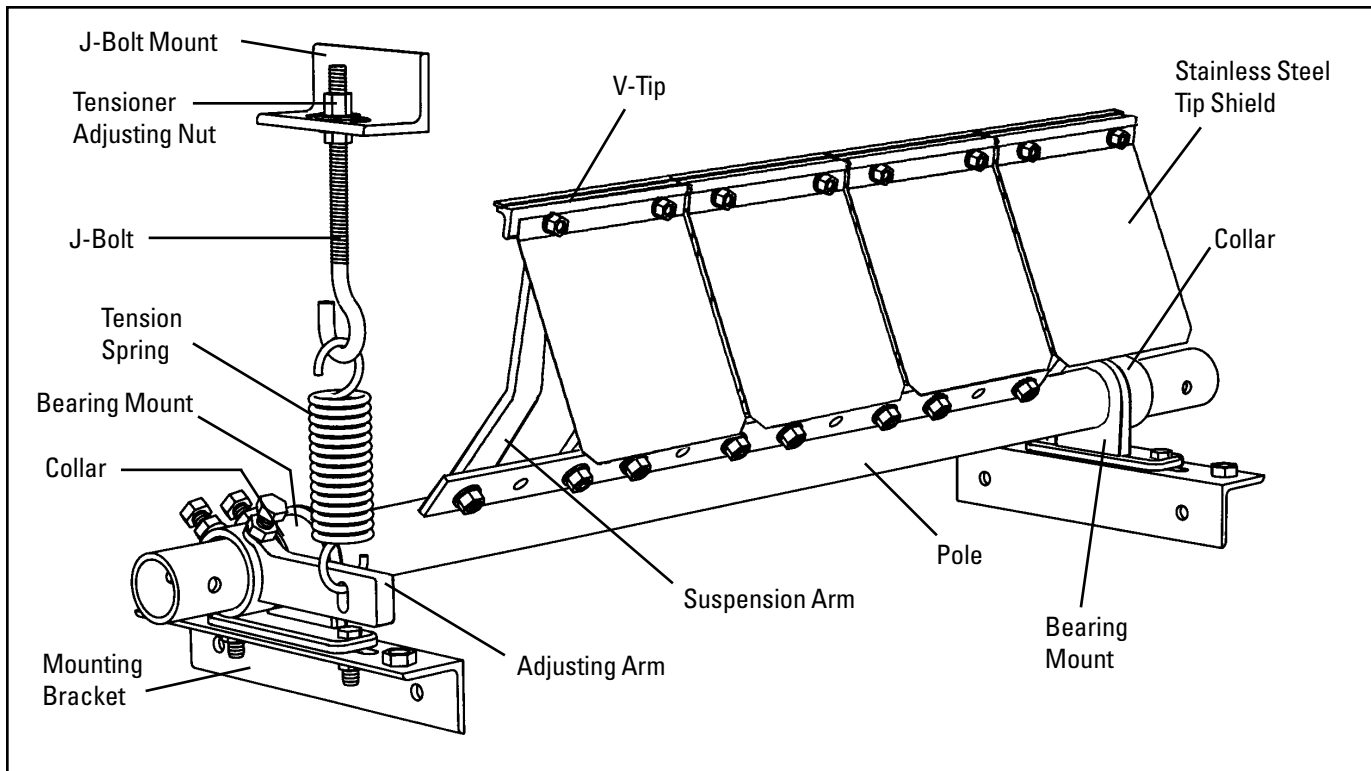

Physically lock out and tag the conveyor at the power source before you begin cleaner installation.

Before You Begin:

- Installation specs and instructions are based on the assumption that the conveyor is in its working position (angle). If the conveyor angle will be different, the cleaner should be installed per the final position. Call the BCP Help Line 1-800-253-8132 if you need help with determining the proper coordinates.
- Choose instructions for chute mounting or open head mounting. For chute mounting it may be necessary to cut an access hole to allow for installation and inspections. (See dimensions in Step 7 under Chute Mounting.)
- Follow all safety precautions when using a cutting torch.
- If welding, protect all fastener threads from weld spatter.

Tools Needed

- Tape Measure
- 3/4" Wrench
- Ratchet With 3/4" Socket
- Adjustable Wrench
- Cutting Torch and/or Welder
- (2) 6" C-Clamps (For Temporary Positioning of Mounting Brackets)
- 24" Level or Eliminator Location Tool
- Marking Pen

V-Tip Size	Pulley Diameter + Belt and Lagging
SS	8" - 15" (200-375mm)
S	16" - 27" (400-675mm)
M	28" - 35" (700-875mm)

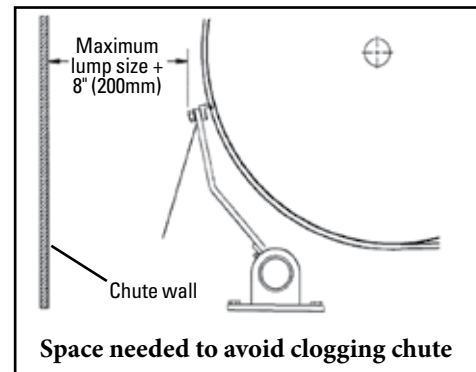

Section 4 – Installation Instructions

4.1 H-Type® High Temp Precleaner with V-Tips (cont.)

Chute Mounting

- 1. Find X and Y measurements.** Find the X and Y measurement specifications for the pulley diameter. See charts on pages 14 and 15. The pulley diameter measurement should include lagging and belt.

Pulley Diameter _____"; X = _____"; Y = _____"

Using the correct X and Y coordinates will position the cleaner at 15° below the horizontal plane on the head pulley.

- 2a. Measure head pulley shaft.** Determine the diameter of the pulley shaft and divide by 2.

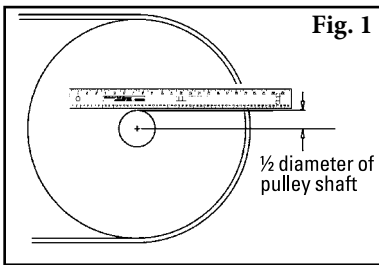

- 2b. Put a level on top of the pulley shaft and draw a horizontal line A.** Measure down from Line A half the diameter of the pulley shaft and draw Line B parallel from the pulley shaft (Fig. 1).

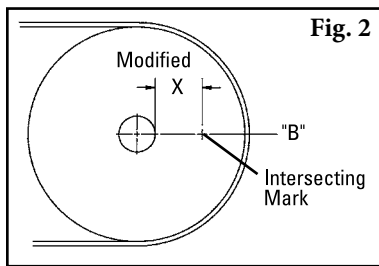

- 3a. Mark X dimension.** Subtract the above dimension (Step 2a) from the selected X dimension to establish the modified X dimension. With this new X dimension measure horizontally from the front of the pulley shaft forward on Line B and mark on the chute (Fig. 2).

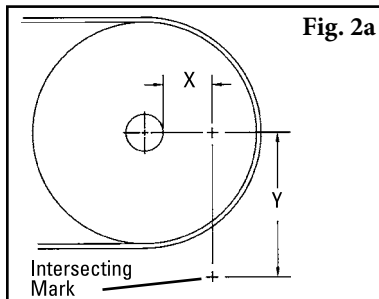

- 3b. Determine Y dimension.** From the horizontal X mark, drop a line vertically down to the selected Y dimension and draw an intersecting mark (Fig. 2a). This is the correct position of the center of the pole.

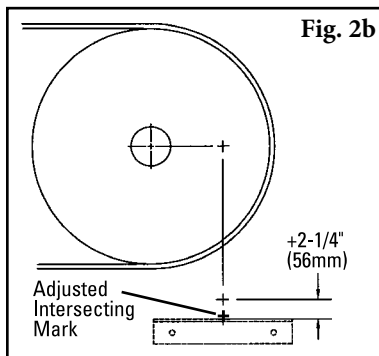

- 4. Locate mounting bracket position (horizontal position).** To locate the position of the cleaner mounting bracket, add 2-1/4" (56mm) to the intersecting mark (Fig. 2b). This mark indicates the top center of the mounting bracket.

Section 4 – Installation Instructions

4.1 H-Type® High Temp Precleaner with V-Tips (cont.)

Chute Mounting (cont.)

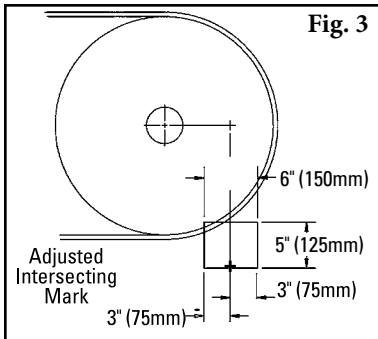

5. **Cut chute opening.** Using the adjusted intersecting mark ("+") established in Step 4, lay out and cut the required opening 5" x 6" (125x150mm) on the chute (Fig. 3). If access hole is required, see Step 7.

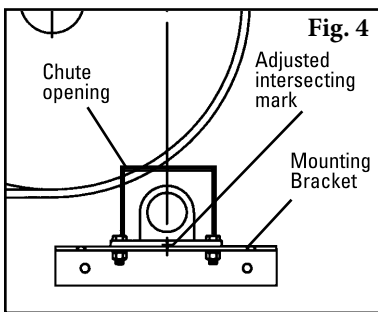

6. **Install the mounting brackets.** Center the mounting bracket on the bottom of the opening. Bolt or weld in position (Fig 4). Repeat process on opposite side.

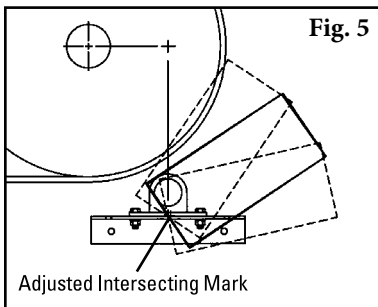

7. **Cutting the access hole.** Cut access hole, centering the bottom edge on the adjusted intersecting mark ("+") established in Step 4. Width of hole should be 5" (125mm); height should be 9-1/2" (238mm) for extra small tips, 12" (300mm) for small tips or 13-1/2" (338mm) for medium tips. Access hole may be oriented within the range shown (Fig. 5), provided bottom edge is still centered as described above.

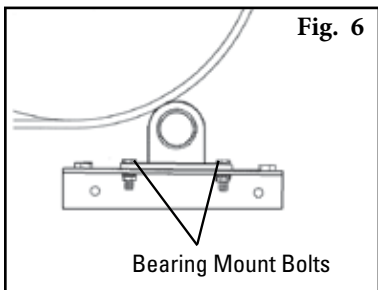

8. **Install the pole.** Remove the two bearing mount bolts from one of the bearing mounts (Fig. 6). (If chute mount, remove from the side with access hole.) Slide the pole across the pulley and into the bearing mount on other side and allow tips to hang down. Install the removed bearing mount on the pole and reattach to the mounting bracket. Do not tighten; leave finger tight.

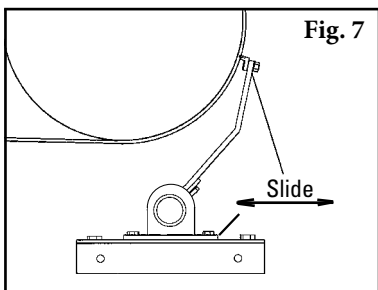

9. **Position the pole.** Rotate pole upward to bring tips into contact with head pulley (Fig. 7). Center the tips across the belt. While applying light pressure on the center tip, shift loosened bearing mount until tips are contacting belt evenly across full width. Lock cleaner into this position by tightening bearing mount bolts.

For step-by-step instructions on installing the spring tensioner, refer to page 12.

Section 4 – Installation Instructions

4.1 H-Type® High Temp Precleaner with V-Tips (cont.)

Open Head Mounting

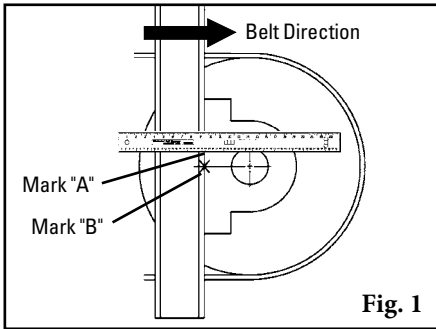

Fig. 1

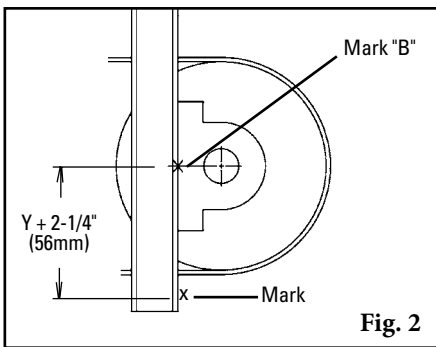

Fig. 2

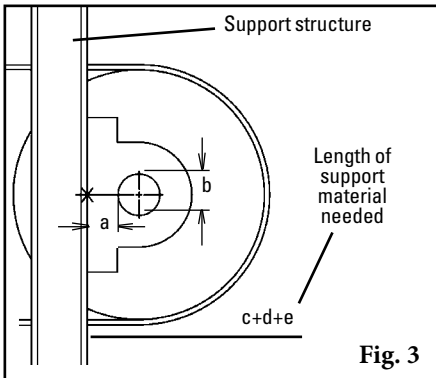

Fig. 3

- 1. Find X and Y measurements.** Find the X and Y measurement specifications for the pulley diameter. See charts on pages 14 and 15. The pulley diameter measurement should include lagging and belt.

Pulley Diameter _____ " X _____ " Y _____ "

Using the correct X and Y coordinates will position the cleaner at 15° below the horizontal plane on the head pulley.

- 2a. Locate Y location.** Determine the diameter of the pulley shaft and divide by 2.
- 2b. Put a level on top of the pulley shaft and mark A at the structure.** Measure down from Mark A half the diameter of the pulley shaft and mark B, locating the shaft centerline (Fig. 1).
- 2c. Measure down the given Y dimension plus 2-1/4" (56mm) and mark (Fig. 2).** This mark indicates the top location of support material to be added for installing the cleaner mounting brackets.

a) shaft to structure	_____	+
b) pulley shaft diameter _____ ÷ 2	_____	+
c) pulley shaft center line to structure	= _____	+
d) add X measurement from chart	_____	+
center of pole from structure	= _____	
e) add 7" (175mm) (half length of mounting bracket)	7" _____	+
length of support material needed	= _____	

- 3. Locate X location.**
 - Measure from the back of the pulley shaft to the support structure (Fig. 3).
 - Pulley shaft diameter divided by 2.
 - Add dimensions from a) and b). This dimension is the pulley shaft centerline to the support structure.
 - Add the given X dimension to c). The sum indicates the distance from the center of the pole to the support structure.
 - Add 7" (175mm) (half the length of the mounting bracket). The sum is the total length of support material needed to correctly locate the mounting brackets.
- 4. Secure mounting support pieces to the support structure.** Weld support pieces to the support structure. 3" x 3" (75x75mm) angle works well for these support pieces.
- 5. Prepare the support pieces for the cleaner mounting brackets.** Clamp the mounting bracket on the support piece. Mark and drill holes for mounting or weld.

Section 4 – Installation Instructions

4.1 H-Type® High Temp Precleaner with V-Tips (cont.)

Open Head Mounting (cont.)

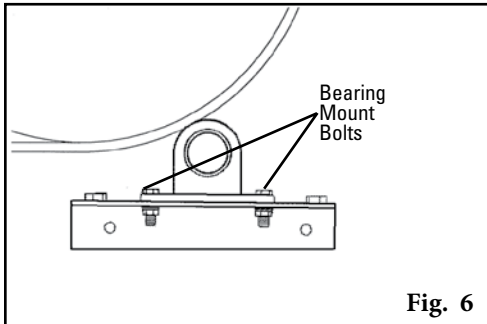

- 6. Install the pole.** Remove the two bearing mount bolts from one of the bearing mounts (Fig. 6). (If chute mount, remove from the side with access hole.) Slide the pole across the pulley and into the bearing mount on other side and allow tips to hang down. Install the removed bearing mount on the pole and reattach to the mounting bracket.
NOTE: Do not tighten; leave finger tight.

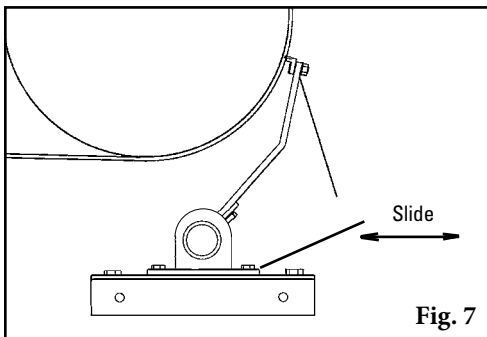

- 7. Position the pole.** Rotate pole upward to bring tips into contact with head pulley (Fig. 7). Center the tips across the belt. While applying light pressure on the center tip, shift loosened bearing mount until tips are contacting belt evenly across full width. Lock cleaner into this position by tightening bearing mount bolts.

Spring Tension Mounting Kit

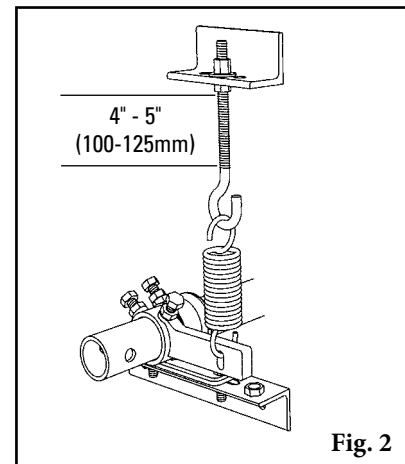
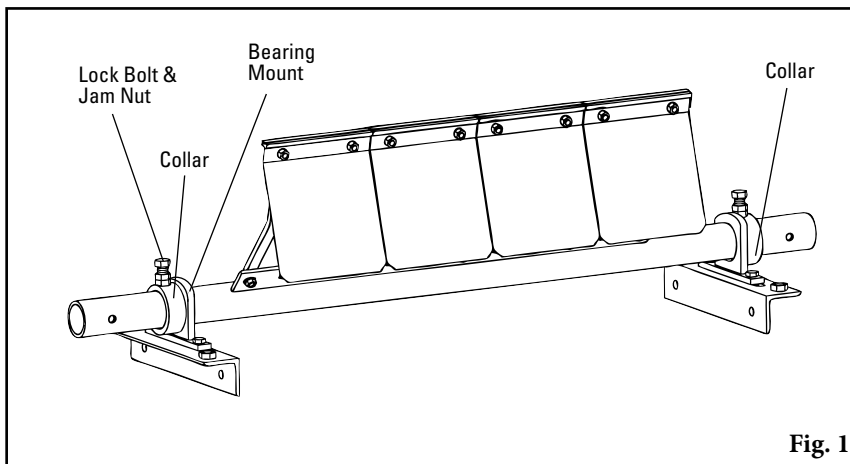

- 8a. Install the Tensioning System.** With the pole rotated up so that all the tips contact the head pulley, slide a collar on each end of the pole. Position the collars tight against the bearing mounts and tighten the lock bolt and jam nut on each collar (Fig. 1).
- 8b. Assemble the tension spring and the J bolt mount to an adjusting arm (Fig. 2).** **IMPORTANT:** Allow for at least 4" to 5" (100-125mm) upward movement on the J bolt for future blade tip adjustments.

Section 4 – Installation Instructions

4.1 H-Type® High Temp Precleaner with V-Tips (cont.)

Spring Tension Mounting Kit (cont.)

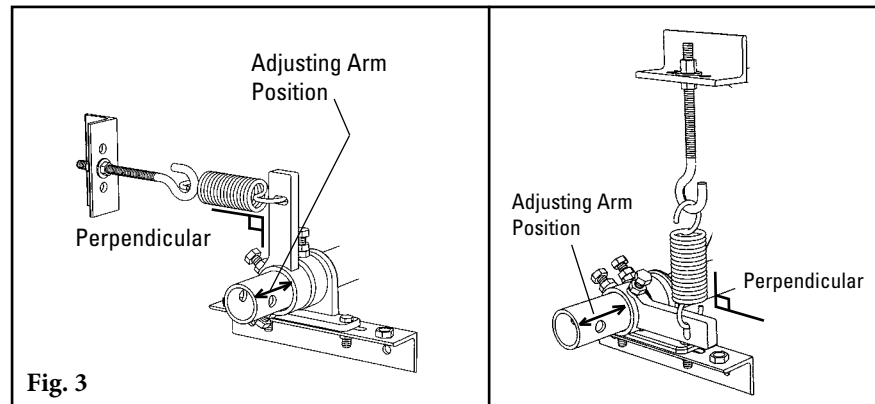

- 8c. Install an adjusting arm onto pole end.** Rotate the tensioner around the pole until the optimum mounting position is located. The J bolt mount can be located in any position 360° around the pole. The only requirement is that the J bolt and spring remain perpendicular to the adjusting arm (Fig. 3). **NOTE:** adjusting arm can be located any place along the end of the pole to align with J bolt mount.
- 8d. Clamp the J bolt mount in place and weld or bolt in position.**
- 8e. With the adjusting arm positioned perpendicular to the J bolt mount, tighten the adjusting arm lock bolts and jam nuts (for optimum hold, tighten the back bolt first and then the top bolt).**
- 8f. The 36" (900mm), 42" (1050mm) & 48" (1200mm) size cleaners require a dual tensioner.** Repeat steps b) through e) on other side of cleaner.

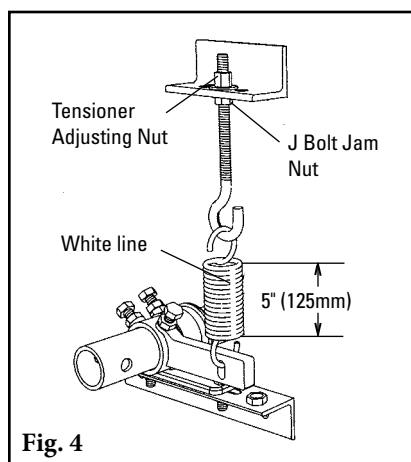

- 9. Set the Spring Tension.** Loosen the J bolt jam nut and turn the tensioner adjusting nut until the coil is 5" (125mm) long. Measure the length of the white line on the spring (Fig. 4). Complete on both sides of cleaner, if required. **NOTE:** The given spring length measurement is a starting point only. Actual length for correct cleaner blade tensioning may vary by cleaner width. Determine exact spring measurement length for your cleaner after Step 12HT is completed.

Section 4 – Installation Instructions

4.1 H-Type® High Temp Precleaner with V-Tips (cont.)

Spring Tension Mounting Kit (cont.)

- 10. Check for Correct Blade Tip Tension.** Place the Tip Tension Gauge (supplied with cleaner) between the blade tip and belt on the center tip (or tips) (Fig. 5). While pulling in a straight motion, read the tension required to break contact between the tip and belt. 18 lbs. (8Kg) is recommended. Also check tension on both outer tips. Make tension adjustments if needed.

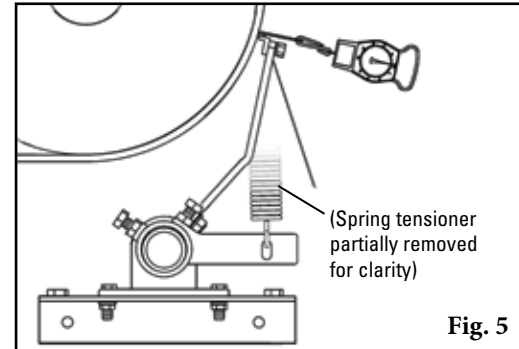

- 11. Measure Spring Length and Affix Label.** After the correct spring tension has been confirmed, measure the white line on the spring. Using a ballpoint pen mark the spring length on the Spring Length label provided in the packet. Affix the label on the conveyor structure near the spring for future reference for tensioning or re-tensioning the blades.

Section 4 – Installation Instructions

4.2 Shimming Instructions

Tools Needed:

- (1) 11/16" (38mm) wrench or crescent wrenches
- (1) 1 1/2" (38mm) wrenches or crescent wrenches
- Shim Kit (provided)

NOTE: If all cleaner tips do not make even contact across the width of the belt, the tips will require shimming (Fig. A and Fig. B).

All shimming is done between the suspension arm bases and the pole plate (Fig. 2).

1. **Remove tension.** Turn adjusting bolt down until a 1/8" (3mm) gap is gained at the tightest point between the tip and the belt (Fig. 1).

2. **Loosen both suspension arm nuts on tip to be shimmed.** Push the tip against the head pulley to move the suspension arms away from the pole plate (Fig. 2).

3. **Determine where to place the shim** (use plastic shims provided).

- To move tip in equally at both ends, place long shim above the suspension arm studs, centered on the two studs (Fig. 3a).
- To move tip in at one end only, place a short shim above the suspension arm stud on the side that must be pulled in (Fig. 3b).
- Shim tips until 1/8" (3mm) gap is obtained across the entire cleaner width (Fig. 3c).

4. **Reset tip tension.**

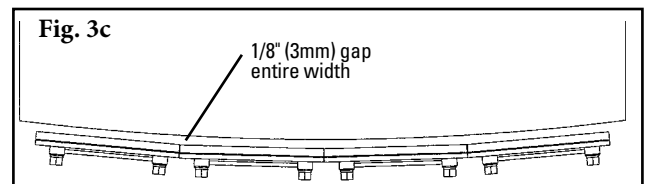
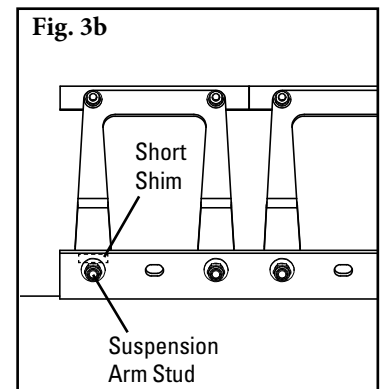
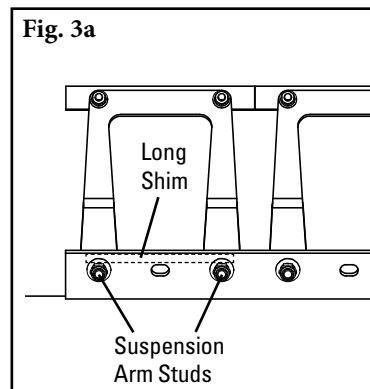
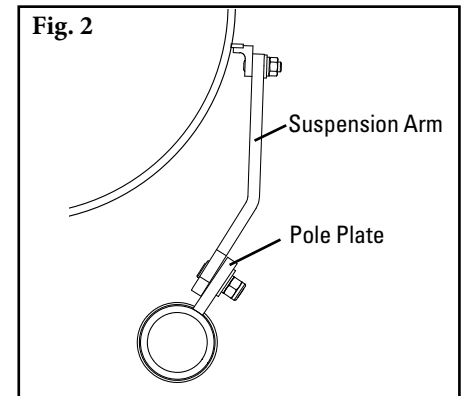
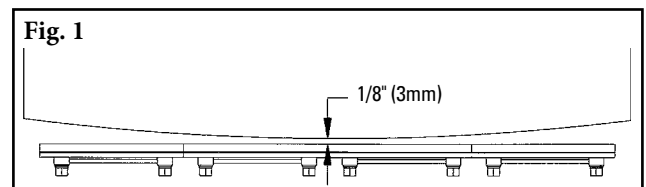
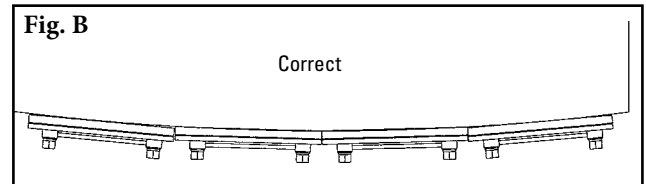
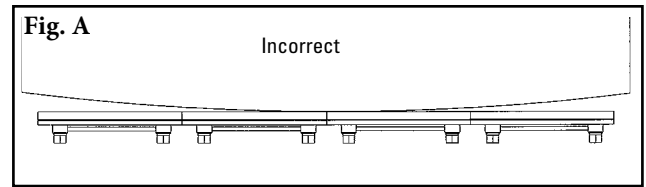

Section 5 – Cleaner Pole Location Charts

5.1 Pole Location Charts

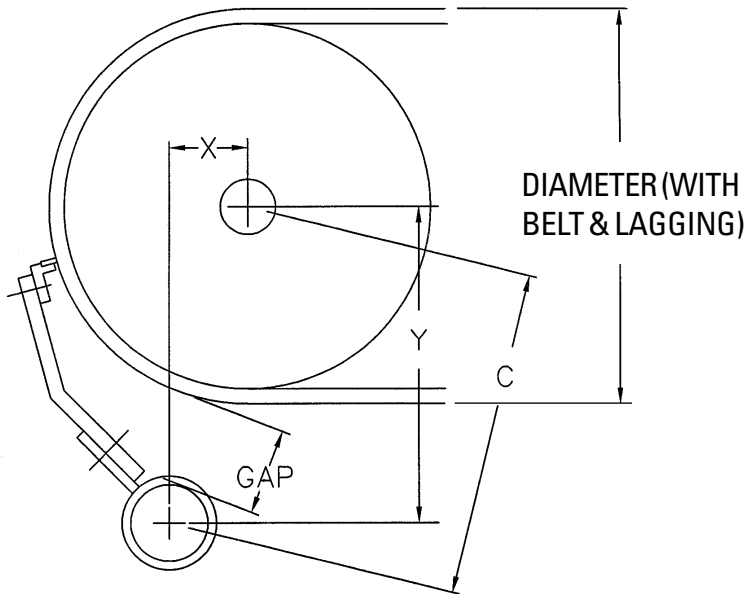

**Extra Small (SS) V-Tips
for Head Pulley Diameters
8" to 15"**

Diameter (Over Belt)	X	Y	C	Gap
8"	1"	7 3/4"	7 3/4"	2 5/8"
9"	1 1/2"	7 7/8"	8"	2 3/8"
10"	2"	8"	8 1/4"	2 1/8"
11"	2 1/2"	8 1/8"	8 1/2"	2"
12"	3"	8 1/4"	8 3/4"	1 3/4"
13"	3 3/8"	8 3/8"	9"	1 5/8"
14"	3 7/8"	8 1/2"	9 3/8"	1 1/2"
15"	4 3/8"	8 5/8"	9 3/4"	1 3/8"

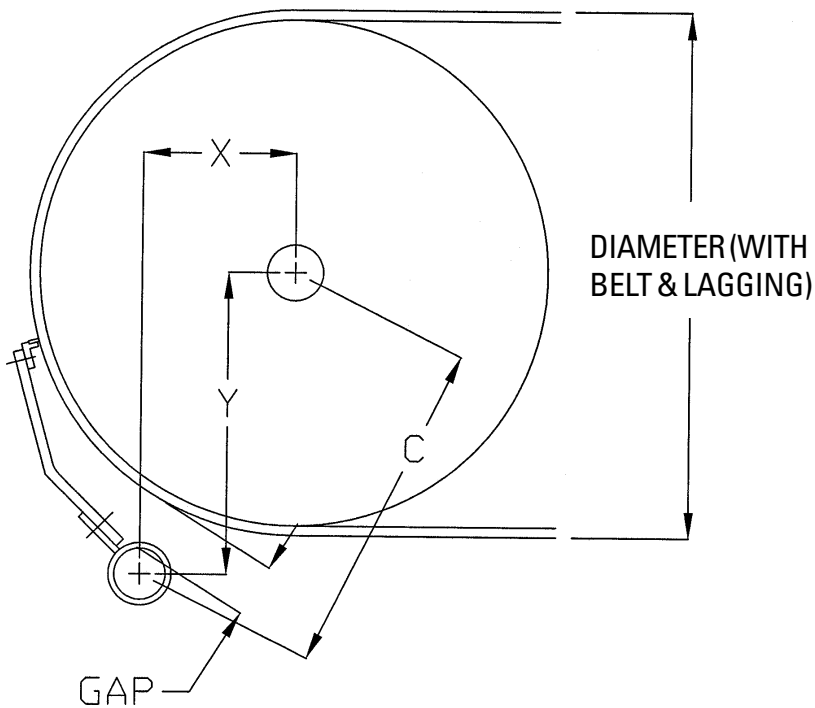

**Small (S) V-Tips
for Head Pulley Diameters
16" to 27"**

Diameter (Over Belt)	X	Y	C	Gap
16"	3 7/8"	11"	11 5/8"	2 5/8"
17"	4 3/8"	11 1/8"	11 7/8"	2 1/2"
18"	4 3/4"	11 1/4"	12 1/4"	2 1/4"
19"	5 1/4"	11 3/8"	12 1/2"	2 1/8"
20"	5 3/4"	11 1/2"	12 7/8"	2"
21"	6 1/4"	11 5/8"	13 1/4"	1 7/8"
22"	6 3/4"	11 3/4"	13 1/2"	1 3/4"
23"	7 1/4"	11 7/8"	13 7/8"	1 5/8"
24"	7 3/4"	12"	14 1/4"	1 1/2"
25"	8 1/4"	12 1/8"	15 5/8"	1 1/2"
26"	8 5/8"	12 1/4"	15"	1 3/8"
27"	9 1/8"	12 3/8"	15 3/8"	1 1/4"

Section 5 – Cleaner Pole Location Charts

5.1 Pole Location Charts (cont.)

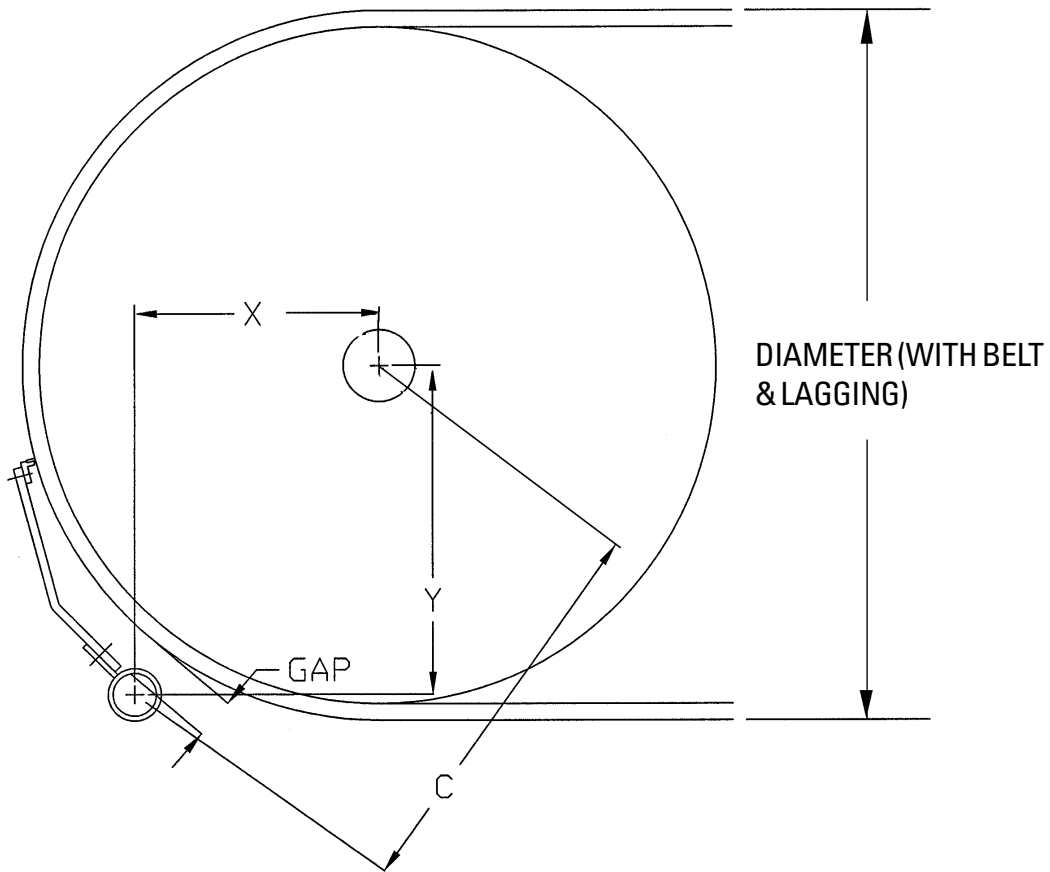

**Medium (M) V-Tips
for Head Pulley Diameters
28" to 35"**

Diameter (Over Belt)	X	Y	C	Gap
28"	9"	14 1/4"	16 7/8"	2 1/4"
29"	9 1/2"	14 1/2"	17 1/4"	2 1/8"
30"	10"	14 5/8"	17 5/8"	2"
31"	10 1/2"	14 3/4"	18 1/8"	1 7/8"
32"	11"	14 7/8"	18 1/2"	1 7/8"
33"	11 1/2"	15"	18 7/8"	1 3/4"
34"	12"	15 1/8"	19 1/4"	1 5/8"
35"	12 3/8"	15 1/4"	19 5/8"	1 5/8"

Section 6 – Pre-Operation Checklist and Testing

6.1 Pre-Op Checklist

- Recheck that all fasteners are tightened properly.
- Add pole caps.
- Apply all supplied labels to the cleaner .
- Check the blade location on the belt.
- Be sure that all installation materials and tools have been removed from the belt and the conveyor area.

6.2 Test Run the Conveyor

- Run the conveyor for at least 15 minutes and inspect the cleaning performance.
- Check the tensioner spring for recommended length (proper tensioning).
- Make adjustments as necessary.

NOTE: Observing the cleaner when it is running and performing properly will help to detect problems or when adjustments are needed later.

Section 7 – Maintenance

Flexco belt cleaners are designed to operate with minimum maintenance. However, to maintain superior performance some service is required. When the cleaner is installed a regular maintenance program should be set up. This program will ensure that the cleaner operates at optimal efficiency and problems can be identified and fixed before the cleaner stops working.

All safety procedures for inspection of equipment (stationary or operating) must be observed. The H-Type® Precleaner operates at the discharge end of the conveyor and is in direct contact with the moving belt. Only visual observations can be made while the belt is running. Service tasks can be done only with the conveyor stopped and by observing the correct lockout/tagout procedures.

7.1 New Installation Inspection

After the new cleaner has run for a few days a visual inspection should be made to ensure the cleaner is performing properly. Make adjustments as needed.

7.2 Routine Visual Inspection (every 2-4 weeks)

A visual inspection of the cleaner and belt can determine:

- If the spring length is the correct length for optimal tensioning.
- If the belt looks clean or if there are areas that are dirty.
- If the blade is worn out and needs to be replaced.
- If there is damage to the blade or other cleaner components.
- If fugitive material is built up on the cleaner or in the transfer area.
- If there is cover damage to the belt.
- If there is vibration or bouncing of the cleaner on the belt.
- If a snub pulley is used, a check should be made for material buildup on the pulley.

If any of the above conditions exist, a determination should be made on when the conveyor can be stopped for cleaner maintenance.

7.3 Routine Physical Inspection (every 6-8 weeks)

When the conveyor is not in operation and properly locked and tagged out a physical inspection of the cleaner to perform the following tasks:

- Clean material buildup off the cleaner blade and pole.
- Closely inspect the blade for wear and any damage. Replace if needed.
- Check both blade pins for proper installation and condition. Replace if needed.
- Ensure full blade to belt contact.
- Inspect the cleaner pole for damage.
- Inspect all fasteners for tightness and wear. Tighten or replace as needed.
- Replace any worn or damaged components.
- Check the tension of the cleaner blade to the belt. Adjust the tension if necessary.
- When maintenance tasks are completed, test run the conveyor to ensure the cleaner is performing properly.

Section 7 – Maintenance

7.4 Blade Replacement Instructions

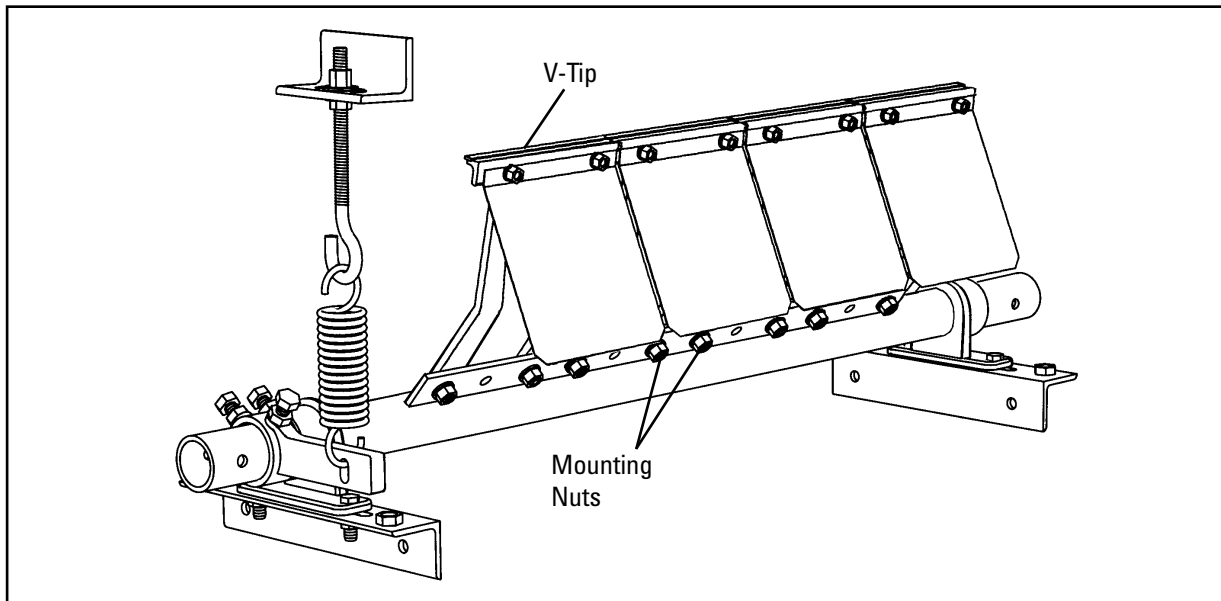

Physically lock out and tag the conveyor at the power source before you begin cleaner installation.

Tools Needed

- Tape measure
- (2) 1½" wrenches or crescent wrenches
- (1) 17mm wrench
- Wire brush (for cleaning pole)
- Small putty knife (for cleaning pole)

1. **Remove the tension.** Loosen the adjusting nuts on the mounting bracket/J-bolt assembly to remove tension from the arm (Fig. 1). This releases the tension of the blade on the belt.
2. **Remove the worn tips.** Remove the nuts on each tip and remove the tips from the cushion (Fig. 2). Clean all fugitive material from the pole. **NOTE:** If tips are hard to remove use a screwdriver or hammer to loosen it and then remove.

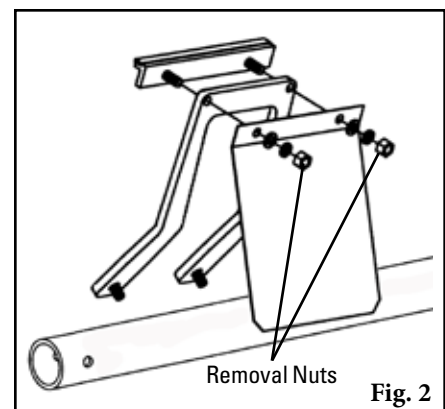
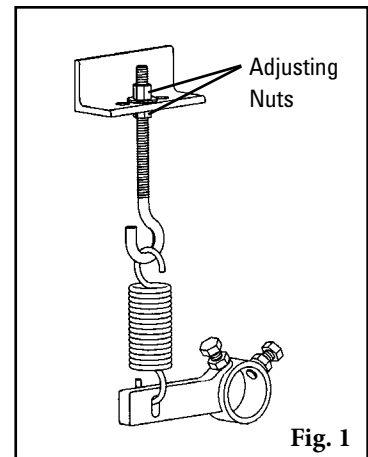

Section 7 – Maintenance

7.4 Blade Replacement Instructions (cont.)

3. **Install the new tips.** Locate each tip onto each suspension arm, then install the hardware to fasten the tip to the cushion (Fig. 3).
4. **Reset the correct blade tension.** Loosen the J bolt jam nut and turn the tensioner adjusting nut until the coil is 5" (125mm) long. Measure the length of the white line on the spring (Fig. 4). Complete on both sides of cleaner, if required. **NOTE:** The given spring length measurement is a starting point only. Actual length for correct cleaner blade tensioning may vary by cleaner width.

Test run the cleaner. Run the conveyor for at least 15 minutes and inspect the cleaning performance. Check the spring length for proper tensioning. Make adjustments as necessary.

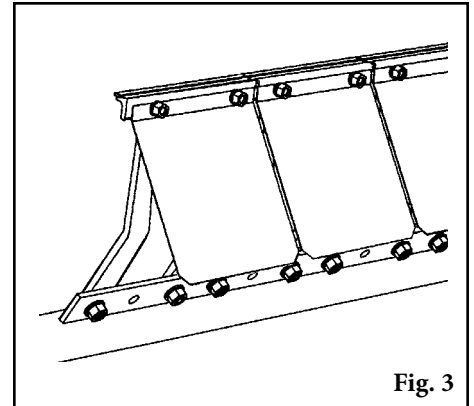

Fig. 3

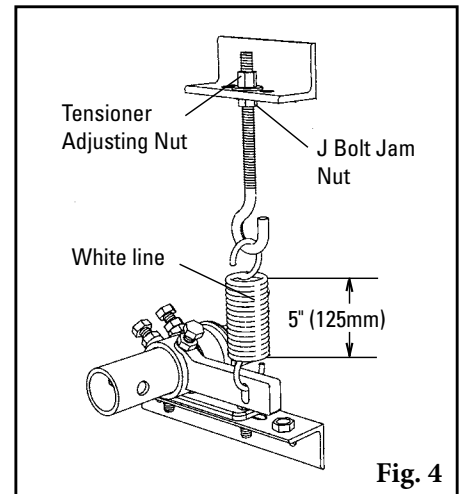

Fig. 4

Section 7 – Maintenance

7.5 Maintenance Log

Conveyor Name/No. _____

Date: _____ Work done by: _____ Service Quote # _____

Activity: _____

Date: _____ Work done by: _____ Service Quote # _____

Activity: _____

Date: _____ Work done by: _____ Service Quote # _____

Activity: _____

Date: _____ Work done by: _____ Service Quote # _____

Activity: _____

Date: _____ Work done by: _____ Service Quote # _____

Activity: _____

Date: _____ Work done by: _____ Service Quote # _____

Activity: _____

Date: _____ Work done by: _____ Service Quote # _____

Activity: _____

Section 7 – Maintenance

7.6 Cleaner Maintenance Checklist

Belt Cleaner: _____ Serial Number: _____

Beltline Information:

Beltline Number: _____ Belt Condition: _____

Belt Width: 18" 450mm 24" 600mm 30" 750mm 36" 900mm 42" 1050mm 48" 1200mm

Head Pulley Diameter (Belt & Lagging): _____ Belt Speed: _____ fpm Belt Thickness: _____

Belt Splice _____ Condition of Splice _____ Number of splices _____ Skived Unskived

Material conveyed _____

Days per week run _____ Hours per day run _____

Blade Life:

Date blade installed: _____ Date blade inspected: _____ Estimated blade life: _____

Is blade making complete contact with belt? Yes No

Blade wear: LEFT _____ MIDDLE _____ RIGHT _____

Blade condition: Good Grooved Smiled Not contacting belt Damaged

Measurement of spring: Required _____ Currently _____

Was Cleaner Adjusted: Yes No

Pole Condition: Good Bent Worn

Lagging: Slide lag Ceramic Rubber Other None

Condition of lagging: Good Bad Other _____

Cleaner's Overall Performance:

(Rate the following 1 - 5, 1 = very poor - 5 = very good)

Appearance: <input type="checkbox"/>	Comments: _____
Location: <input type="checkbox"/>	Comments: _____
Maintenance: <input type="checkbox"/>	Comments: _____
Performance: <input type="checkbox"/>	Comments: _____

Other Comments: _____



Section 8 – Troubleshooting

Problem	Possible Cause	Possible Solutions
Poor cleaning performance	Cleaner under-tensioned	Adjust to correct tension – see spring length chart
	Cleaner over-tensioned	Adjust to correct tension – see spring length chart
	Cleaner installed in wrong location	Verify "C" dimension, relocate to correct dimension
	Cleaner blade worn or damaged	Replace cleaner blade
Rapid Blade Wear	Tension on cleaner too high/low	Adjust to correct tension – see spring length chart
	Cleaner not located correctly	Check cleaner location for correct dimensions
	Blade attack angle incorrect	Check cleaner location for correct dimensions
	Material too abrasive for blade	Option: switch to alternate cleaner with metal blades
	Mechanical splice damaging blade	Repair, skive or replace splice
Center wear on blade (smile effect)	Blade wider than material path	Replace blade with width to match material path
	Tension on cleaner too high/low	Adjust to correct tension – see spring length chart
Unusual wear or damage to blade	Mechanical splice damaging blade	Repair, skive or replace splice
	Belt damaged or ripped	Repair or replace belt
	Cleaner not correctly located	Verify "C" dimension, relocate to correct dimension
	Damage to pulley or pulley lagging	Repair or replace pulley
Vibration or noise	Cleaner not located correctly	Verify "C" dimension, relocate to correct dimension
	Blade attack angle incorrect	Verify "C" dimension, relocate to correct dimension
	Cleaner running on empty belt	Use a spray pole when the belt is empty
	Cleaner tension too high/low	Adjust to correct tension or slight adjust to diminish
	Cleaner locking bolts not secure	Check and tighten all bolts and nuts
	Cleaner not square to head pulley	Verify "C" dimension, relocate to correct dimension
	Material buildup in chute	Clean up build-up on cleaner and in chute
Cleaner being pushed away from pulley	Cleaner tension not set correctly	Ensure correct tension/increase tension slightly
	Sticky material is overburdening cleaner	Increase tension; replace with cleaner with metal tips; replace with larger size cleaner
	Cleaner not set up correctly	Confirm location dimensions are equal on both sides

Section 9 – Specs and CAD Drawings

9.1 Specifications and Guidelines

Pole Length Specifications*

Cleaner Size		Pole Length		Maximum Conveyor Span	
in.	mm	in.	mm	in.	mm
18	450	66	1650	56	1400
24	600	72	1800	62	1550
30	750	78	1950	68	1700
36	900	84	2100	74	1850
42	1050	90	2250	80	2000
48	1200	96	2400	86	2150

*For special extra long pole length requirements a Pole Extender Kit.
Pole Diameter - 2-3/5" (60mm)

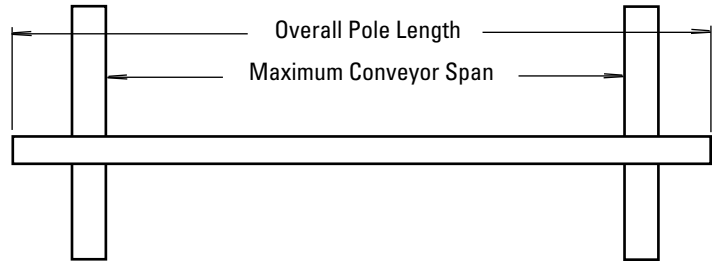

Clearance Guidelines for Installation

Suspension Arm Size	Horizontal Clearance Required		Vertical Clearance Required	
	in.	mm	in.	mm
SS	7	175	9	229
S	7	175	11	279
M	7	175	12 1/2	318

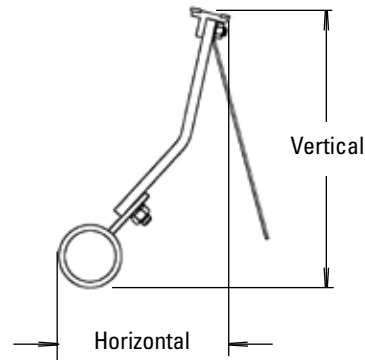

Specifications:

- Maximum Belt Speed 1000 FPM (5M/sec)
- Temperature Rating -30°F to 400°F (-35°C to 204°C)
- Usable Blade Wear Length 3/8" (9mm)
- Blade Material..... Long Life Tungsten Carbide (for vulcanized belts only)
- Available for Belt Widths 18" to 48" (450 to 1200mm).
Other sizes available upon request.
- CEMA Cleaner Rating Class 3

Section 9 – Specs and CAD Drawings

9.2 CAD Drawing - High Temp Precleaner with V-Tips - SS

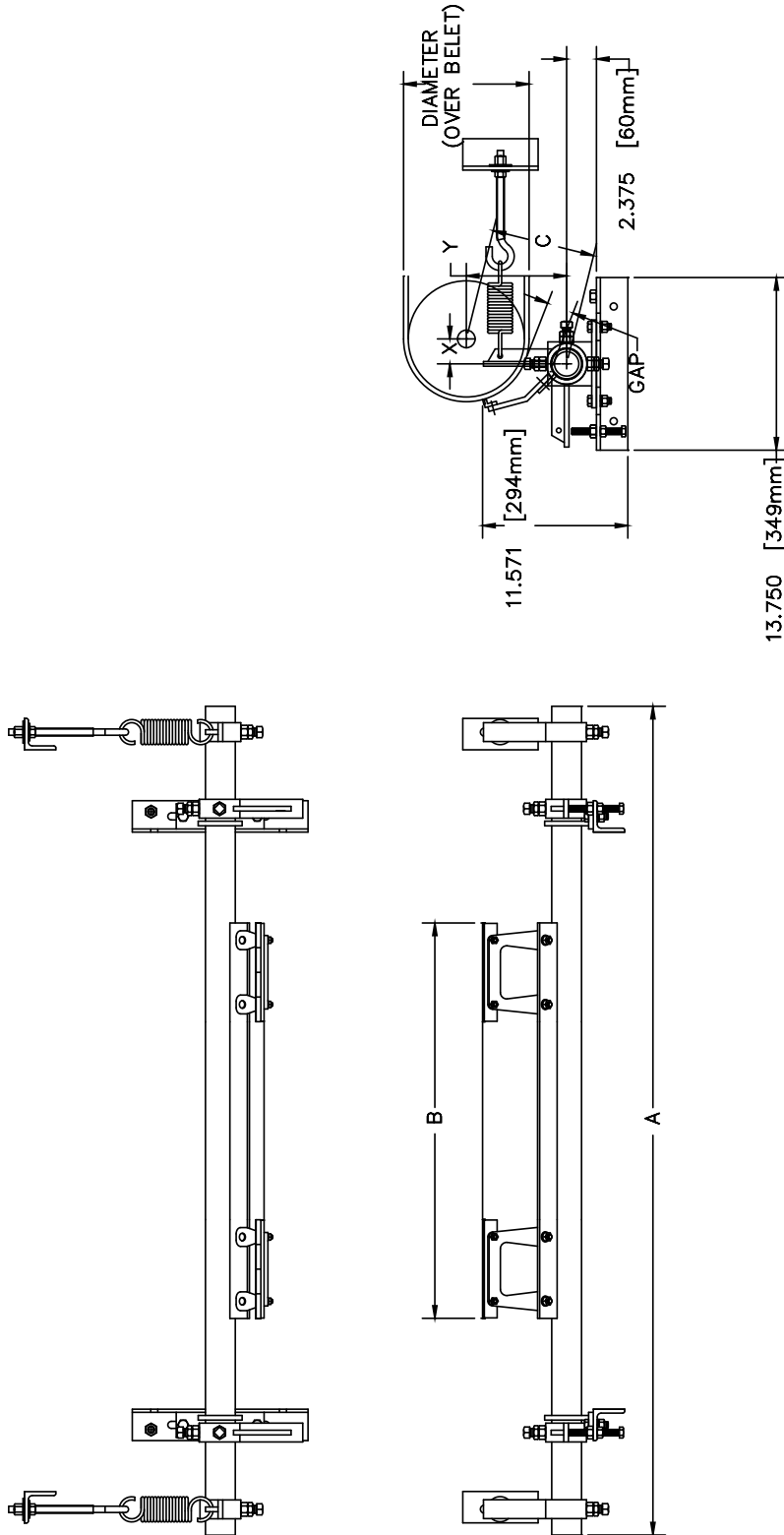

DIAMETER (OVER BELET)	X	Y	C	GAP
8	1	7-3/4	7-3/4	2-5/8
9	1-1/2	7-7/8	8	2-3/8
10	2	8	8-1/4	2-1/8
11	2-1/2	8-1/8	8-1/2	2
12	3	8-1/4	8-3/4	1-3/4
13	3-3/8	8-3/8	9	1-5/8
14	3-7/8	8-1/2	9-3/8	1-1/2
15	4-3/8	8-5/8	9-3/4	1-3/8

C LEANER	BELT WIDTH	"A"	"B"	NO. OF BLADES
74821	18"	48"	15.75"	2
74822	24"	54"	23.62"	3
74823	30"	60"	31.62"	3
78424	36"	66"	31.45"	4
74825	42"	72"	39.37"	5
74826	48"	78"	39.37"	5

Section 9 – Specs and CAD Drawings

9.2 CAD Drawing - High Temp Precleaner with V-Tips - S

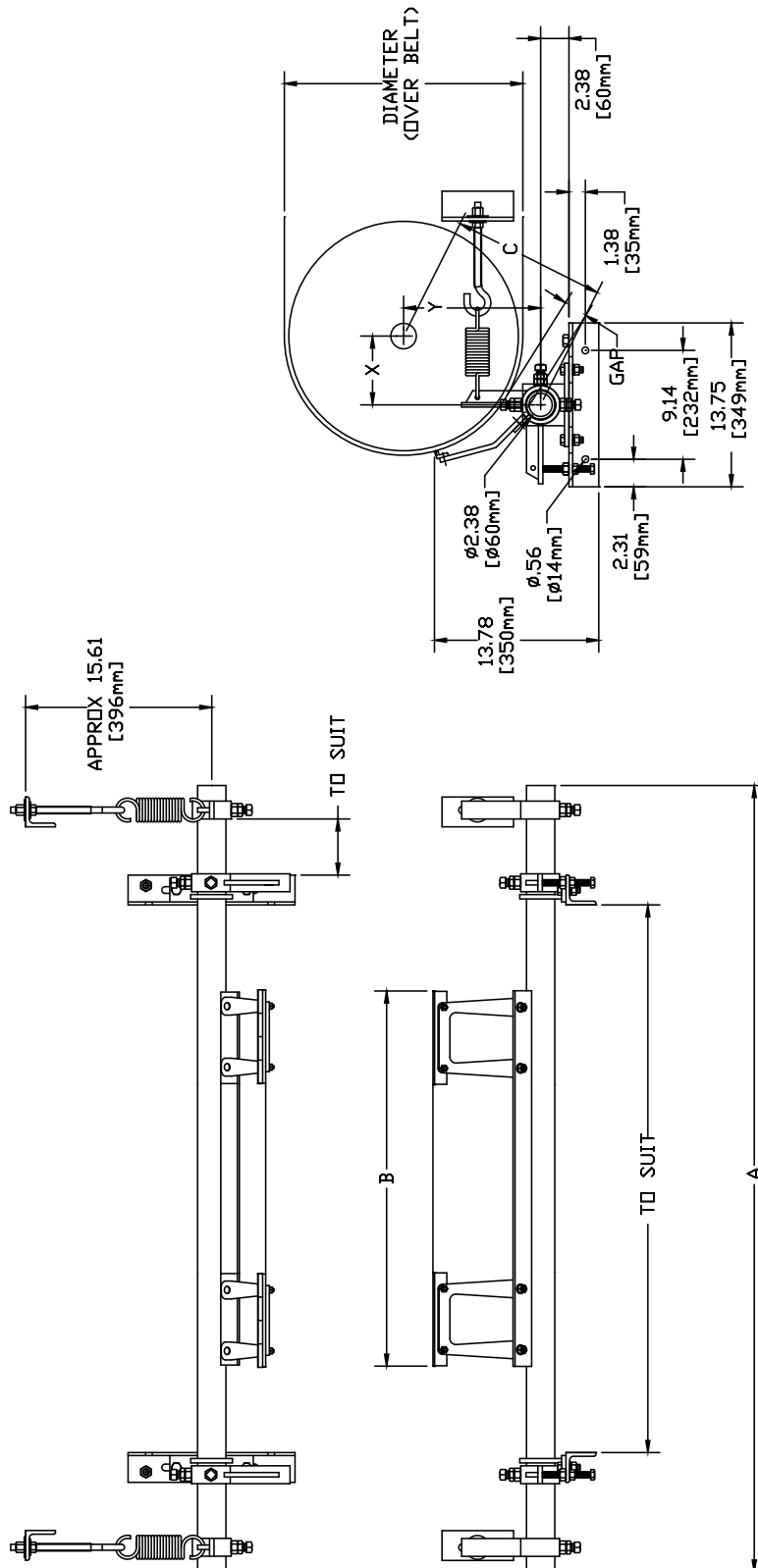

DIAMETER (OVER BELT)	X	Y	C	GAP
16	3-7/8	11	11-5/8	2-5/8
17	4-3/8	11-1/8	11-7/8	2-1/2
18	4-3/4	11-1/4	12-1/4	2-1/4
19	5-1/4	11-3/8	12-1/2	2-1/8
20	5-3/4	11-1/2	12-7/8	2
21	6-1/4	11-5/8	13-1/4	1-7/8
22	6-3/4	11-3/4	13-1/2	1-3/4
23	7-1/4	11-7/8	13-7/8	1-5/8
24	7-3/4	12	14-1/4	1-1/2
25	8-1/4	12-1/8	14-5/8	1-1/2
26	8-5/8	12-1/4	15	1-3/8
27	9-1/8	12-3/8	15-3/8	1-1/4

CLEANER	BELT WIDTH	"A"	"B"	NO. OF BLADES
74828	18"	48"	15.75"	2
74829	24"	54"	23.62"	3
74830	30"	60"	23.62"	3
74831	36"	66"	31.45"	4
74832	42"	72"	39.37"	5
74833	48"	78"	39.37"	5



Section 9 – Specs and CAD Drawings

9.2 CAD Drawing - High Temp Precleaner with V-Tips - M

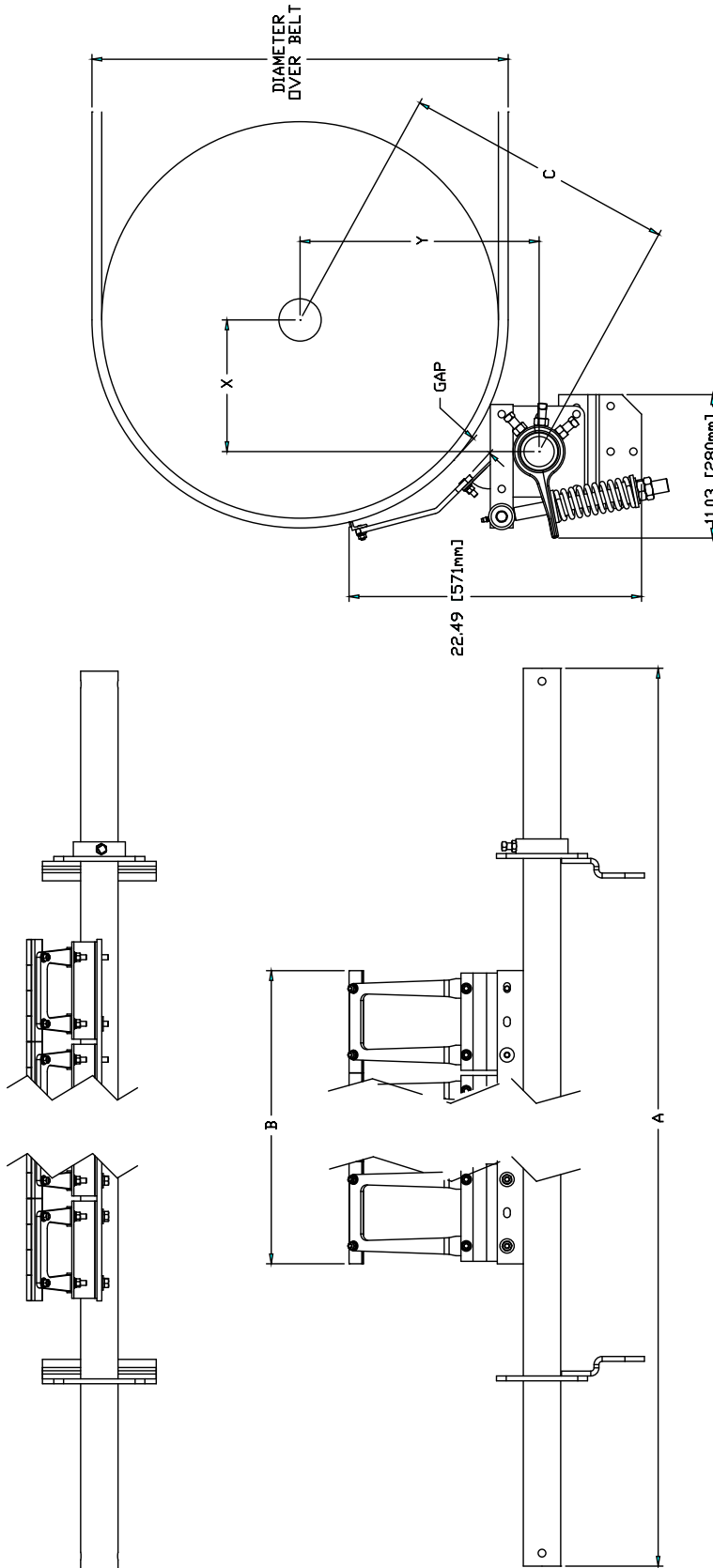

DIAMETER (INCLUDING BELT)	POLE LOCATION CHART			
	X	Y	C	GAP
*26	7-1/4	17-5/8	19	2-3/8
*27	7-3/4	17-3/4	19-3/8	2-3/8
*28	8-1/4	17-7/8	19-5/8	2-1/4
*29	8-3/4	18	20	2-1/8
*30	9-1/4	18-1/8	20-3/8	2
31	9-3/4	18-1/4	20-5/8	1-7/8
32	10-1/8	18-3/8	21	1-7/8
33	10-5/8	18-1/2	21-3/8	1-3/4
34	11-1/8	18-5/8	21-3/4	1-5/8
35	11-5/8	18-3/4	22-1/8	1-5/8
36	12-1/8	18-7/8	22-3/8	1-1/2
37	12-5/8	19	22-3/4	1-3/8
38	13-1/8	19-1/8	23-1/8	1-3/8
39	13-1/2	19-1/4	23-5/8	1-1/4
*40	14	19-3/8	24	1-1/4
*41	14-1/2	19-1/2	24-3/8	1-1/8
*42	15	19-5/8	24-3/4	1-1/8
*43	15-1/2	19-3/4	25-1/8	1-1/8
*44	16	19-7/8	25-1/2	1
*45	16-1/2	20	26	1

* OPTIONAL EXTENDED RANGE

CLEANER	BELT WIDTH	"A"	"B"	NO. OF BLADES
76191	18"	60"	15.75"	2
76193	24"	66"	23.62"	3
76195	30"	72"	23.62"	3
76197	36"	78"	31.50"	4
76251	42"	84"	39.38"	5
76255	48"	90"	39.38"	5
76258	54"	96"	47.25"	6
76261	60"	108"	55.12"	7
76264	72"	120"	63.00"	8

Section 10 – Replacement Parts List

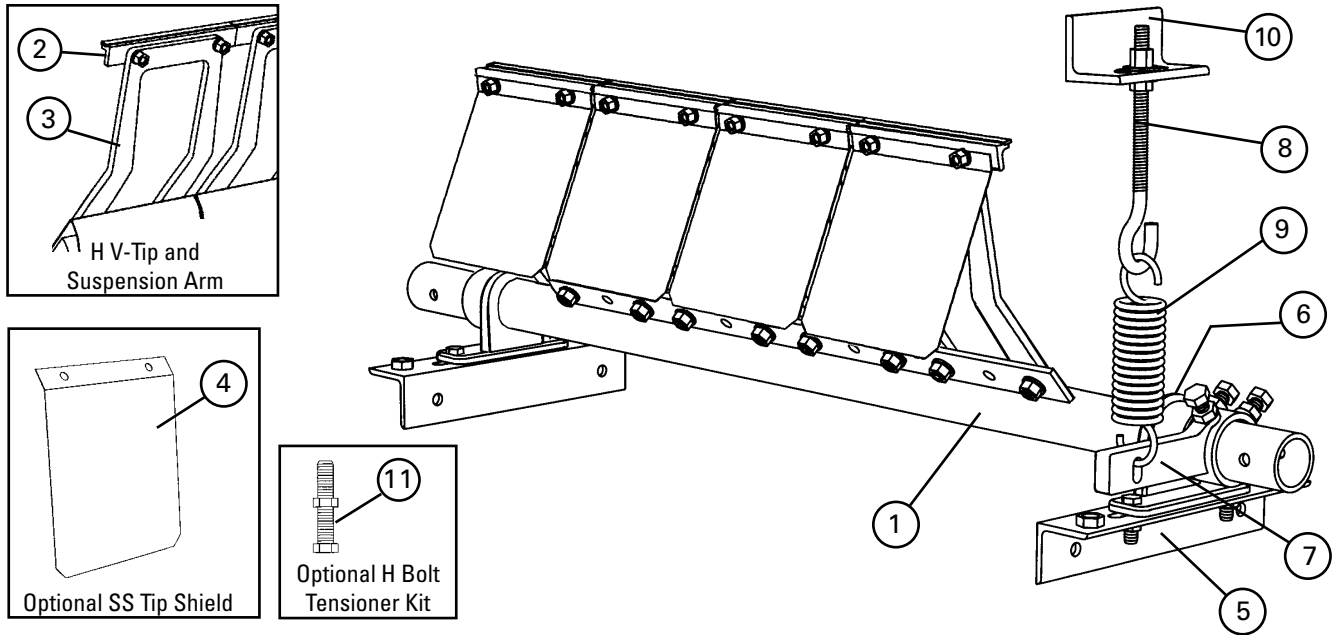

Replacement Parts

Ref	Description	Ordering Number	Item Code	Wt. Lbs.
1	18" (450mm) Pole	HP-18	78990	23.0
	24" (600mm) Pole	HP-24	78991	27.0
	30" (750mm) Pole	HP-30	78992	29.0
	36" (900mm) Pole	HP-36	78993	33.0
	42" (1050mm) Pole	HP-42	78994	43.0
	48" (1200mm) Pole	HP-48	78995	47.0
2	H V-Tip S/S (for vulcanized belts only)	HVT8-S/S	73042	1.0
3	H SS Suspension Arm*	HSA8SS	73047	0.5
	H S Suspension Arm*	HSA8S	73048	1.0
	H M Suspension Arm*	HSA8M	73049	1.5
4	H SS Tip Shield	HSSTS	74771	0.5
5	H Mounting Bracket Repair Kit* (includes 1 mounting bracket)	HMRK	74582	10.0
6	H Bearing Repair Kit* (includes 1 bearing)	HBRK	73068	6.0
7	H Adjusting Arm Repair Kit* (includes 1 adjusting arm)	HAR-K	78786	6.0
8	J-Bolt Kit* (includes 1 ea.)	STJK	74417	0.7
9	HT Tension Spring (includes 1 ea.)	HTTS-HT	79068	1.4
10	Spring Tensioner J-Bolt Mount (incl. 1 ea.)	STJM	74775	3.0

Ref	Description	Ordering Number	Item Code	Wt. Lbs.
-	H Mounting/J-Bolt Kit - Single (incl. 1 ea. items 5, 6, 7, 8, 9, 10) (for sizes 18" to 30")	H-MK1	78987	20.0
-	H Mounting/J-Bolt Kit - Dual (incl. 2 ea. items 5, 6, 7, 8, 9, 10) (for sizes 36" to 48")	H-MK2	78801	24.4
-	Spring Tension Kit - Single (incl. 1 ea. items 8, 9, 10) (for sizes 18" to 30")	STKS	74505	6.8
-	Spring Tension Kit - Dual (includes 2 ea. items 8, 9, 10) (for sizes 36" to 48")	STKD	74504	11.2
11	H Bolt Tensioner Kit (includes 2 adjusting bolts & 2 jam nuts)	HBTK	74776	0.5

*Hardware included
Pole Diameter - 2-3/8" (60mm)
Lead time: 1 working day

Section 11 – Other Flexco Conveyor Products

Flexco provides many conveyor products that help your conveyors to run more efficiently and safely. These components solve typical conveyor problems and improve productivity. Here is a quick overview on just a few of them:

Rockline® EZP1 Precleaner



- Patented ConShear™ blade renews its cleaning edge as it wears
- Visual Tension Check™ for optimal blade tensioning and simple retensioning
- Quick and easy one-pin blade replacement Material Path Option™ for optimal cleaning and reduced maintenance

DRX Impact Beds



- Exclusive Velocity Reduction Technology™ to better protect the belt
- Slide-Out Service™ gives direct access to all impact bars for change-out
- Impact bar supports for longer bar life
- 4 models to custom fit to the application

Rockline® EZS2 Secondary Cleaner

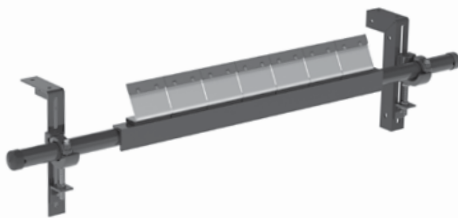

- Long-wearing tungsten carbide blades for superior cleaning efficiency
- Patented FormFlex™ cushions independently tension each blade to the belt for consistent, constant cleaning power
- Easy to install, simple to service
- Works with Flexco mechanical belt splices

PT Max™ Belt Trainer



- Patented “pivot & tilt” design for superior training action
- Dual sensor rollers on each side to minimize belt damage
- Pivot point guaranteed not to freeze or seize up
- Available for topside and return side belts

Flexco Specialty Belt Cleaners



- “Limited space” cleaners for tight conveyor applications
- High Temp cleaners for severe, high heat applications
- A rubber fingered cleaner for chevron and raised rib belts
- Multiple cleaner styles in stainless steel for corrosive applications

Belt Plows

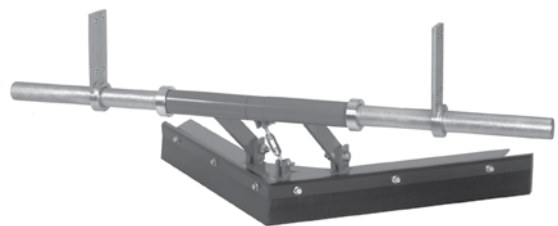

- A belt cleaner for the tail pulley
- Exclusive blade design quickly spirals debris off the belt
- Economical and easy to service
- Available in vee or diagonal models

The Flexco Vision

To become the leader in maximising
belt conveyor productivity for our customers worldwide
through superior service and innovation.



2525 Wisconsin Avenue • Downers Grove, IL 60515-4200 • USA
Tel: (630) 971-0150 • Fax: (630) 971-1180 • E-mail: info@flexco.com

Visit www.flexco.com for other Flexco locations and products.

©2017 Flexible Steel Lacing Company. 03/30/17. For reorder: X2374

