

MHS Stainless Heavy-Duty Secondary Belt Cleaner

Superior Cleaning on the Toughest Belts

The MHS Heavy-Duty Stainless Steel Secondary Belt Cleaner was designed to deliver and maintain superior cleaning efficiency, even on the most demanding, abusive beltlines. The MHS SS is the new answer to tough belt cleaning problems. It delivers high-efficiency cleaning and long-lasting performance, with low maintenance.

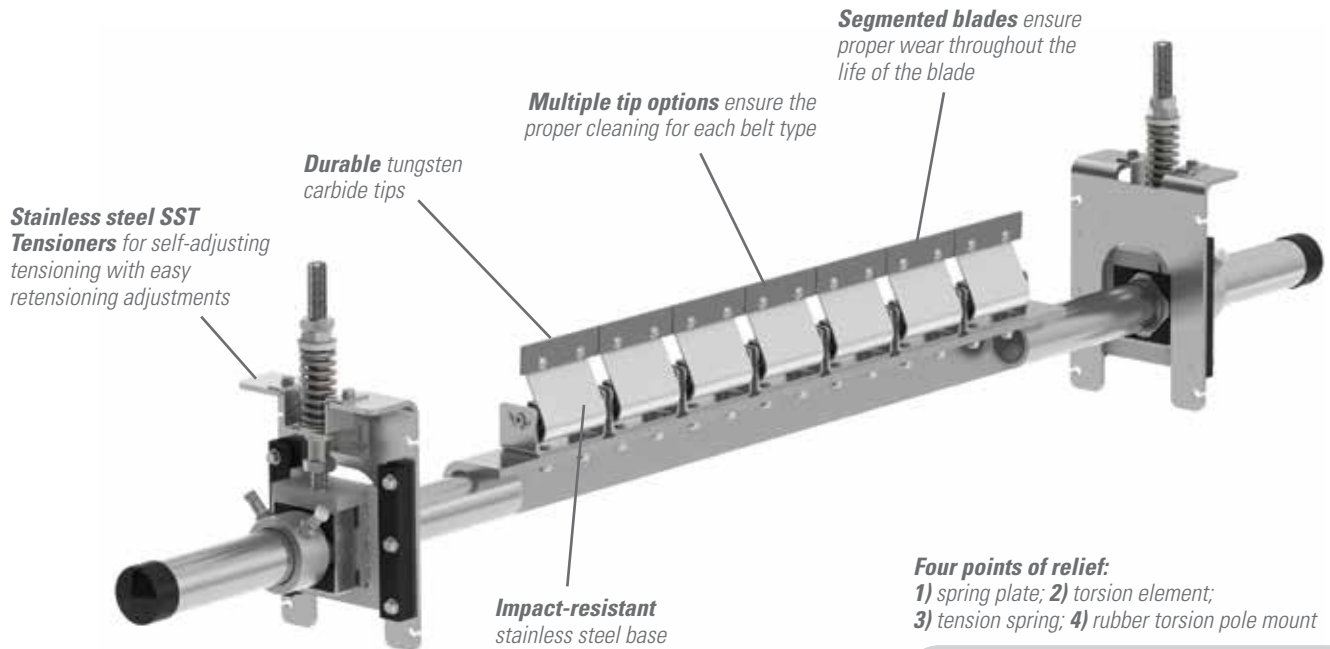

Features and Benefits

- **Stainless steel.** Corrosive environments wear on any component, but stainless steel can protect against that.
- **Cleaning efficiency of metal blades.** The thin, hard edges of the metal blades deliver high cleaning efficiency and long wear life.
- **Works with Flexco and other mechanical splices.** The C-Tip tungsten carbide blades are impact resistant, and the spring cushion allows them to move away from a passing splice without damage and with minimal cleaning disruption. The V-Tip can be used on vulcanized belts.
- **Made for mining conveyors.** Made from heavy-duty, corrosion-resistant stainless steel, the MHS is available for belt widths from 24" to 96" (600 to 2400mm). Additional sizes are available upon request.
- **Complete cleaning system.** When the MHS is teamed with the MMP Precleaner, the system provides maximum cleaning power for tough applications.
- **Safe to service.** All service can be performed from a safe position at the side of the conveyor.

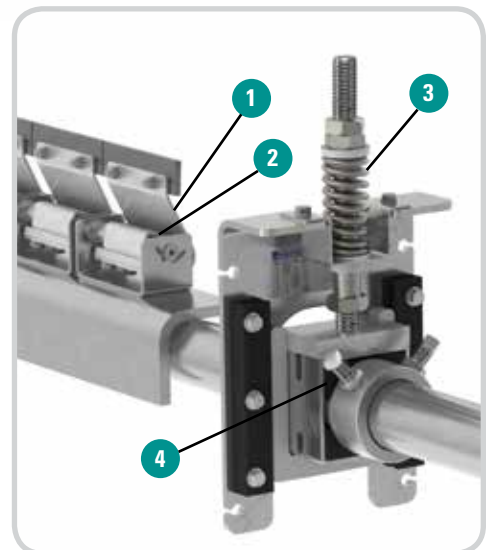

MHS Stainless

Heavy-Duty Secondary Belt Cleaner

Specifications and Guidelines

- **Maximum Belt Speed**
1200 FPM (6 M/sec)
- **Temperature Rating**
-30°F to 180°F (-35°C to 82°C)
- **Usable Blade Wear Length**
3/8" (9 mm)
- **CEMA Cleaner Rating**
Class 5
- **Blade Material**
Impact resistant, long-lasting tungsten carbide (C-Tip for mechanical fasteners, V-Tip for vulcanized belts)
- **Available for Belt Widths**
24" to 96" (450 to 2400mm)
- **Horizontal Clearance Required**
4" (100mm)
- **Vertical Clearance Required**
10" (245mm)
- **Pole Length**
Cleaner size + 54" (1350mm)
- **Maximum Conveyor Span**
Cleaner size + 44" (1100mm)

Clearance Requirement Specs

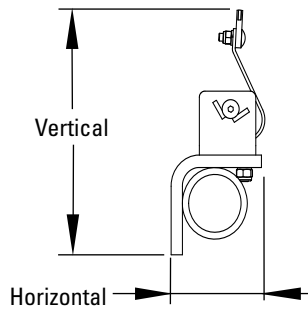

Pole Length and Conveyor Span Specs

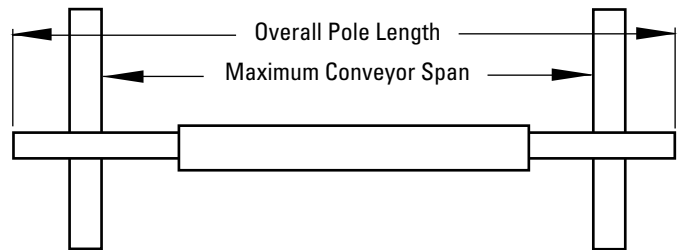

Ordering Information

MHS SS Secondary Cleaners with C-Tips

Belt Width		Ordering Number	Item Code
in.	mm		
24	600	MHS-24-S/S	77601
30	750	MHS-30-S/S	77602
36	900	MHS-36-S/S	77603
42	1050	MHS-42-S/S	77604
48	1200	MHS-48-S/S	77605
54	1350	MHS-54-S/S	77606
60	1500	MHS-60-S/S	77607
72	1800	MHS-72-S/S	77608
84	2100	MHS-84-S/S	77609
96	2400	MHS-96-S/S	79048

MHS SS Secondary Cleaners with V-Tips

Belt Width		Ordering Number	Item Code
in.	mm		
24	600	MHS-24V-S/S	77610
30	750	MHS-30V-S/S	77611
36	900	MHS-36V-S/S	77612
42	1050	MHS-42V-S/S	77613
48	1200	MHS-48V-S/S	77614
54	1350	MHS-54V-S/S	77615
60	1500	MHS-60V-S/S	77616
72	1800	MHS-72V-S/S	77617
84	2100	MHS-84V-S/S	77618
96	2400	MHS-96V-S/S	79049

MHS SS Reversing Secondary Cleaners with C-Tips

Belt Width		Ordering Number	Item Code
in.	mm		
24	600	MHS-24R-S/S	77640
30	750	MHS-30R-S/S	77641
36	900	MHS-36R-S/S	77642
42	1050	MHS-42R-S/S	77643
48	1200	MHS-48R-S/S	77644
54	1350	MHS-54R-S/S	77645
60	1500	MHS-60R-S/S	77646
72	1800	MHS-72R-S/S	77647
84	2100	MHS-84R-S/S	77648
96	2400	MHS-96R-S/S	79050

MHS SS Reversing Secondary Cleaners with V-Tips

Belt Width		Ordering Number	Item Code
in.	mm		
24	600	MHS-24RV-S/S	77649
30	750	MHS-30RV-S/S	77650
36	900	MHS-36RV-S/S	77651
42	1050	MHS-42RV-S/S	77652
48	1200	MHS-48RV-S/S	77653
54	1350	MHS-54RV-S/S	77654
60	1500	MHS-60RV-S/S	77655
72	1800	MHS-72RV-S/S	77656
84	2100	MHS-84RV-S/S	77657
96	2400	MHS-96RV-S/S	79051

Lead time: 1 working day

Shaded items are made to order.
Lead time: 3 weeks

Replacement Tips

Ordering Number	Item Code
ICT6	74535
RSA150	73628
RVT6-S/S	76205

Lead time: 1 working day

Tips Required Per Cleaner Size

in.	18	24	30	36	42	48	54	60	72	84	96
mm	450	600	750	900	1050	1200	1350	1500	1800	2100	2400
C-Tips or V-Tips Required	3	4	5	6	7	8	9	10	12	14	16

Authorized Distributor:

2525 Wisconsin Avenue • Downers Grove, IL 60515-4200 • USA
Tel: (630) 971-0150 • Fax: (630) 971-1180 • E-mail: info@flexco.com

Visit www.flexco.com for other Flexco locations and products.

©2016 Flexible Steel Lacing Company. 02/16. For reorder: X2364

