

MMP Stainless Medium-Duty Precleaner

Extra Cleaning Power for Corrosive Environments

The MMP Stainless Steel Medium-Duty Precleaner tackles those tough applications where the standard-duty precleaner is not sturdy enough but the heavy-duty cleaner is overkill. The MMP is built tough with a stainless steel heavy-duty pole and beefy dual tensioning system, and a larger, powerful blade. Yet installation is simple, maintenance is quick, and bottom line—the cleaning job is excellent.

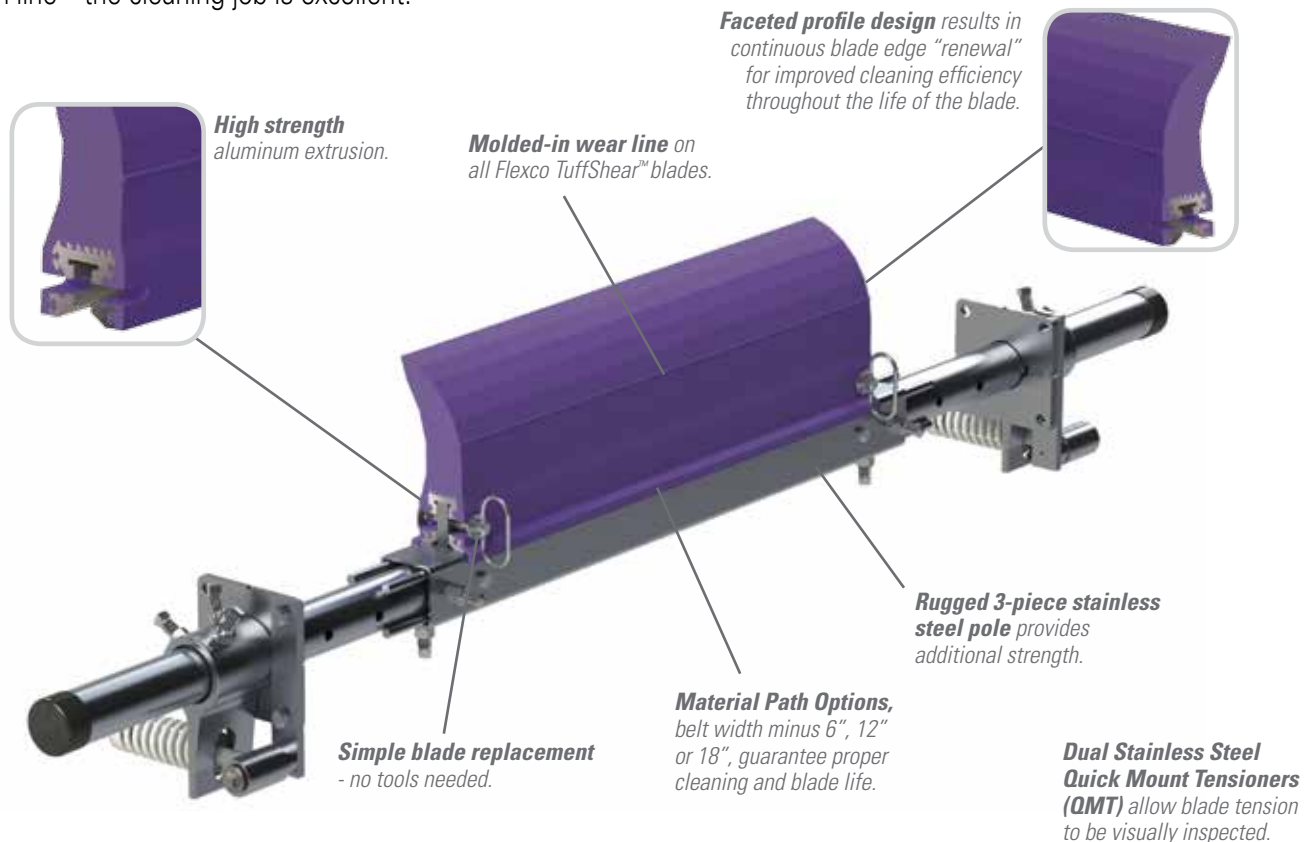

Features and Benefits

- **Stainless steel.** Corrosive environments wear on any component, but stainless steel can protect against that.
- **Compact and versatile.** Requires only 4" (100mm) of horizontal clearance for installation. Pole length is belt width plus 54" (1350mm) to fit varying conveyor or chute wall widths. Pole extenders are available for extended length requirements.
- **Works with Flexco and other mechanical splices.** The spring tensioner quickly moves the blade away from the belt when a splice passes. The polyurethane blade easily glides over the splice without damage and with minimal cleaning disruption.
- **Made for mining conveyors.** Made from heavy-duty stainless steel, the MMP is available for belt widths from 24" to 84" (600 to 2100mm). Special sizes are available upon request.
- **Complete cleaning system.** When teamed with our MHS Secondary Cleaner, it makes up a system that delivers maximum cleaning power. If extra water is present, the MDWS DryWipe can be added.



MMP Stainless

Medium-Duty Precleaner

Specifications and Guidelines

- **Maximum Belt Speed**
1000 FPM (5 M/sec)
- **Temperature Rating**
-30°F to 180°F (-35°C to 82°C)
- **Minimum Pulley Diameter**
16" (400 mm)
- **Blade Height**
10" (250 mm)
- **Useable Blade Wear Length**
6" (150 mm)
- **Blade Material**
Urethane 83 durometer (proprietary blend for abrasion resistance and long wear)
- **Available for Belt Widths**
24" to 84" (600 to 2100mm)
- **CEMA Cleaner Rating**
Class 4
- **Horizontal Clearance Required**
4" (100mm)
- **Vertical Clearance Required**
13" (325mm)
- **Pole Length**
Cleaner size + 54" (1350mm)
- **Maximum Conveyor Span**
Cleaner size + 42" (1050mm)

Pole Location Specs

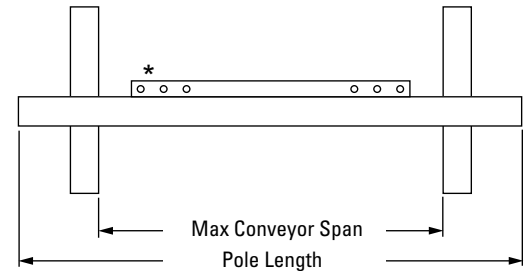
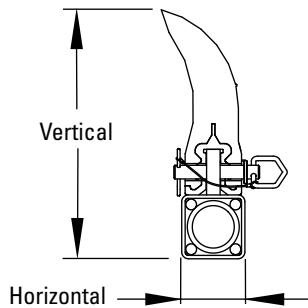
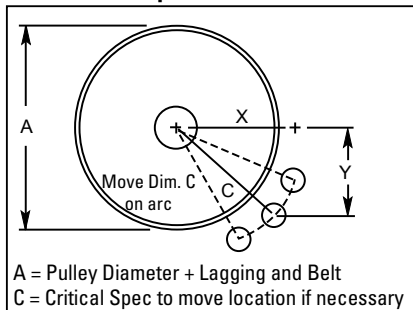

Pole Location Chart											
A	X	Y	C	A	X	Y	C	A	X	Y	C
16"	8-1/8"	12"	14-1/2"	27"	14-1/8"	12"	18-1/2"	38"	19-3/4"	12"	23-1/8"
17"	8-3/4"	12"	14-7/8"	28"	14-5/8"	12"	18-7/8"	39"	20-3/8"	12"	23-5/8"
18"	9-1/4"	12"	15-1/8"	29"	15-1/4"	12"	19-3/8"	40"	20-3/4"	12"	24"
19"	9-3/4"	12"	15-1/2"	30"	15-5/8"	12"	19-3/4"	41"	21-3/8"	12"	24-1/2"
20"	10-3/8"	12"	15-7/8"	31"	16-1/8"	12"	20-1/8"	42"	21-3/4"	12"	24-7/8"
21"	11"	12"	16-1/4"	32"	16-3/4"	12"	20-5/8"	43"	22-3/8"	12"	25-3/8"
22"	11-1/2"	12"	16-5/8"	33"	17-1/4"	12"	21"	44"	22-3/4"	12"	25-3/4"
23"	12"	12"	17"	34"	17-3/4"	12"	21-3/8"	45"	23-3/8"	12"	26-1/4"
24"	12-5/8"	12"	17-3/8"	35"	18-1/4"	12"	21-7/8"	46"	23-7/8"	12"	26-3/4"
25"	13-1/8"	12"	17-3/4"	36"	18-3/4"	12"	22-1/4"	47"	24-3/8"	12"	27-1/8"
26"	13-5/8"	12"	18-1/8"	37"	19-3/8"	12"	22-3/4"	48"	24-7/8"	12"	27-5/8"

Ordering Information

MMP SS Precleaners - Belt Width Minus 6"					
Belt Width		Blade Coverage		Ordering Number	Item Code
in.	mm	in.	mm		
24	600	18	450	MMP-624-S/S	77424
30	750	24	600	MMP-630-S/S	77425
36	900	30	750	MMP-636-S/S	77426
42	1050	36	900	MMP-642-S/S	77427
48	1200	42	1050	MMP-648-S/S	77428
54	1350	48	1200	MMP-654-S/S	77429
60	1500	54	1350	MMP-660-S/S	77430
72	1800	66	1650	MMP-672-S/S	77431
84	2100	78	1950	MMP-684-S/S	77432

MMP SS Precleaners - Belt Width Minus 12"					
Belt Width		Blade Coverage		Ordering Number	Item Code
in.	mm	in.	mm		
30	750	18	450	MMP-1230-S/S	77433
36	900	24	600	MMP-1236-S/S	77434
42	1050	30	750	MMP-1242-S/S	77435
48	1200	36	900	MMP-1248-S/S	77436
54	1350	42	1050	MMP-1254-S/S	77437
60	1500	48	1200	MMP-1260-S/S	77438
72	1800	60	1500	MMP-1272-S/S	77439
84	2100	72	1800	MMP-1284-S/S	77440

TuffShear™ Replacement Blades				
Blade Width		Ordering Number	Item Code	
in.	mm			
18	450	TRB18	76485	
24	600	TRB24	76486	
30	750	TRB30	76487	
36	900	TRB36	76488	
42	1050	TRB42	76489	
48	1200	TRB48	76490	
54	1350	TRB54	76491	
60	1500	TRB60	76492	
66	1650	TRB66	76493	
72	1800	TRB72	76494	
78	1950	TRB78	76697	

Lead time: 1 working day

Shaded items are made to order.
Lead time: 3 weeks

Authorized Distributor:



2525 Wisconsin Avenue • Downers Grove, IL 60515-4200 • USA
Tel: (630) 971-0150 • Fax: (630) 971-1180 • E-mail: info@flexco.com

Visit www.flexco.com for other Flexco locations and products.

