

Installing Flexco® BR6 & BR10 Fasteners with the Electric Powered Rivet Driver and the Standard MBRTA Installation Tool

Warning: Follow all maintenance and safety precautions that are noted in the Hitachi manual included in this kit. We recommend a trial drive prior to production installation. Use of this driver will vary with the length of the rivet and the type of belt you are using.

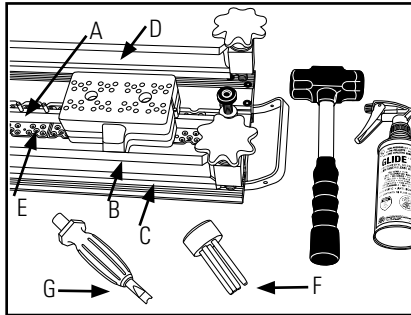

- A: Alignment Bar
- B: Clamp Bars
- C: Channel Base
- D: Guide Blocks
- E: Anvil Plates
- F: SR759
- G: Bridge Removal Tool

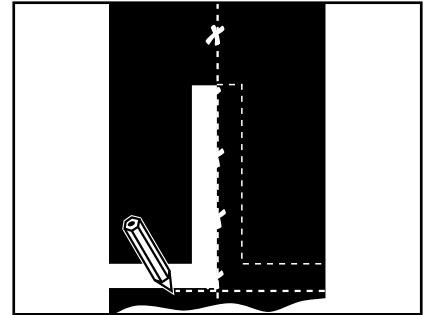

1. Square belt using centerline method. Cut belt at least 4" (100 mm) behind old splice using a Flexco belt cutting tool. Skive belt when top cover permits.

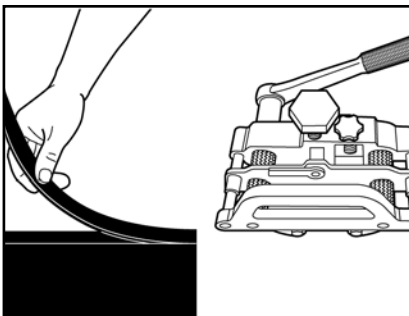

2. For belts with a top cover of 3/16" (4.8 mm) or more, skiving is recommended. Refer to FSK™ Belt Skiver instructions.

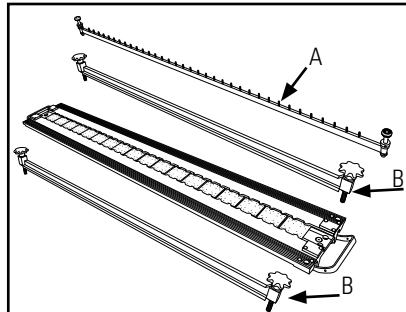

3. Remove alignment bar (A) and clamp bars (B).

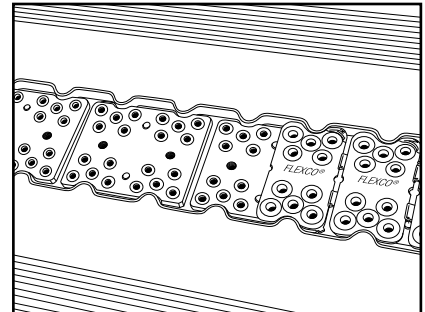

4. Centering the fasteners on the tool, place proper number of fasteners on anvil plates with Flexco® facing up.

Secure fasteners with black retainers between fasteners and tool:

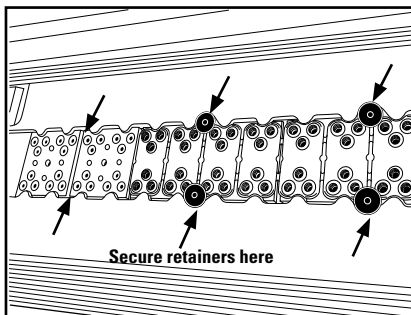

For BR6

5A. Insert retainers between anvil plates, securing fasteners every four plates on top and bottom of splice.

For BR10

5B. Insert retainers at center of anvil plate, securing fasteners every four plates on top and bottom of splice.

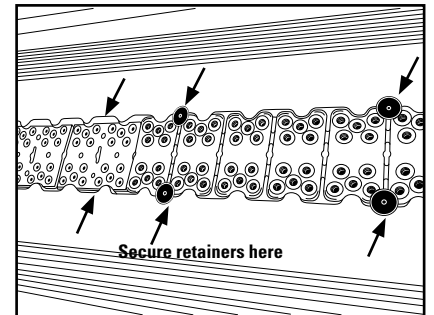

Installing Flexco® BR6 & BR10 Fasteners with MBRT-AL Tool with Electric Powered Rivet Driver

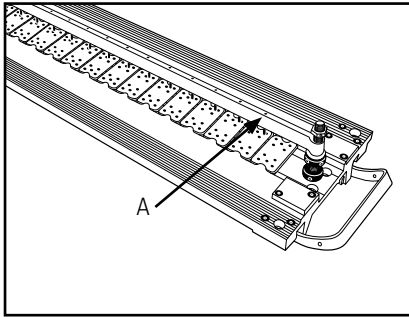

6. Place alignment bar (A) upside down on tool over bottom plates and tighten alignment bar screws.

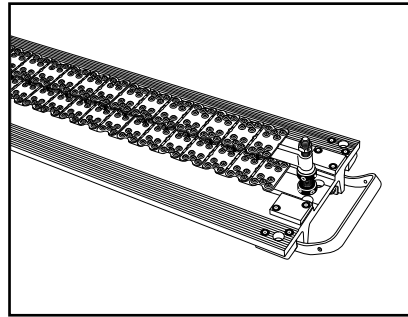

7. Place top plates on alignment bar, Flexco facing up, and align with bottom plates.

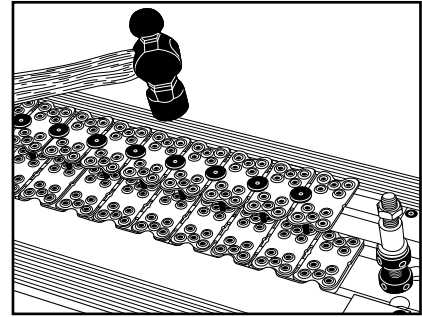

8. Insert black retainers between every plate and tap with hammer. Remove alignment bar and set to side.

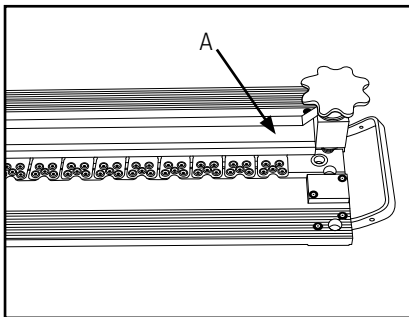

9. Place clamp bar (A) on tool so that one edge of the clamp bar is over the center of the fasteners strips.

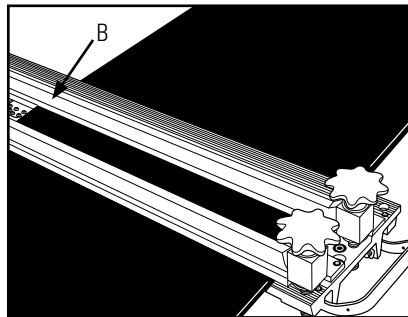

10. Square belt against centered clamp bar (B). Center belt over bottom plates. Place second clamp bar onto belt and tighten securely. Do not overtighten.

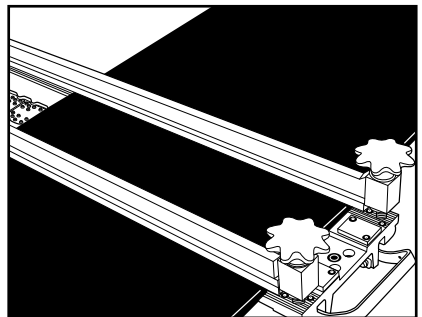

11. Remove centered clamp bar. Position loose belt end against secured belt end, alignment center lines. Clamp belt in place.

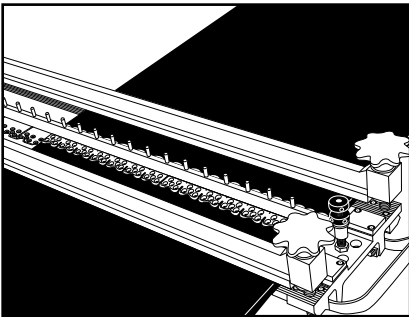

12. Insert alignment bar in ends of MBRT. Tighten top knurled nut. Tighten lower knurled nut to lower fasteners to belt surface. Do not overtighten.

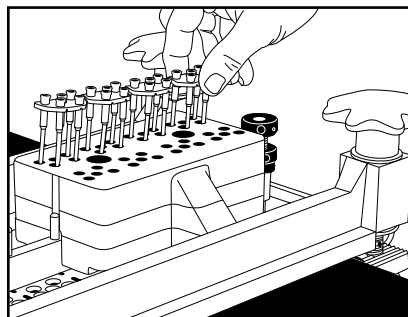

13. Starting at center of belt, place guide block onto alignment bar. Load rivets. Spray top of guide blocks with silicone spray. Using a 4 lb. (1.8 kg) hammer and driver, drive rivets in the sequence shown below.

Rivet Sequence:

1. Drive rivets in opposite corners. (1 & 2)
2. Drive top row of rivets working out from corner. (3, 4, & 5)
3. Drive bottom row of rivets working out from corner. (6, 7, & 8)

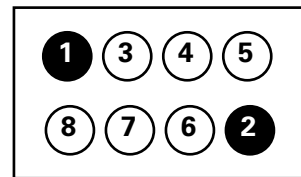

Flexco® Rivet Selection Gauge

Rivet Size	Belt Thickness Range			
	BR6		BR10	
	in.	mm	in.	mm
A	1/4 - 11/32	6.5 - 9	7/32 - 5/16	6 - 8
B	5/16 - 13/32	8 - 10.5	9/32 - 3/8	7 - 9.5
C	3/8 - 15/32	9.5 - 12	11/32 - 7/16	9 - 11
C/D	7/16 - 17/32	11 - 13.5	13/32 - 1/2	10 - 13
D	1/2 - 19/32	13 - 15	15/32 - 9/16	12 - 14
E	9/16 - 21/32	14 - 17	17/32 - 5/8	13.5 - 16
F	N/A	N/A	19/32 - 11/16	15 - 17

If installing SRH or longer rivets: Using SR-50 Single Rivet Driver and 2 lb (0.9 kg) hammer, drive rivets in each end and center of splice. Remove alignment bar. Drive remaining rivets. Skip step 11.

Installing Flexco® BR6 & BR10 Fasteners with MBRT-AL Tool with Electric Powered Rivet Driver

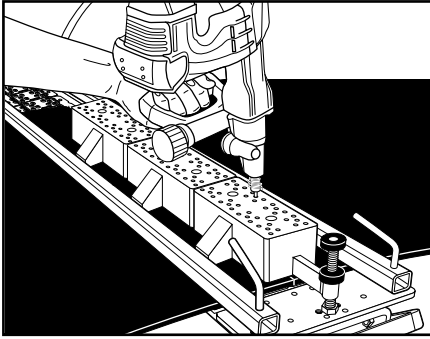

14. Insert the punch directly into the BR500 Guide Block. Keeping the tool perpendicular to the base, pull the trigger to fire the driver. Push down on the driver slightly and maintain force on the driver until you feel the rivet set. This should take approximately 1 to 2 seconds per rivet depending on the length of the rivet and the type of belt.

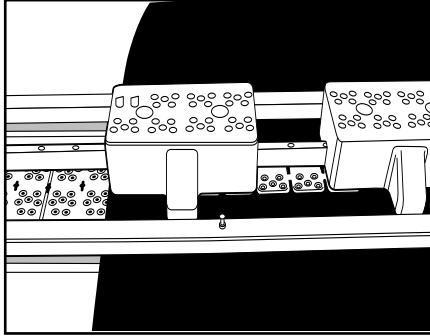

15. Move guide block(s) directly to the right and/or left of belt center and drive the next block(s) of rivets.

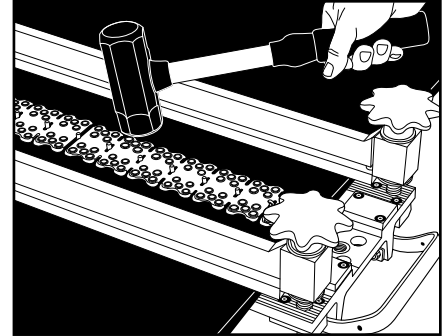

16. Remove alignment bar (A). Set rivets with firm hammer blows. Belt should pucker around fastener edges.

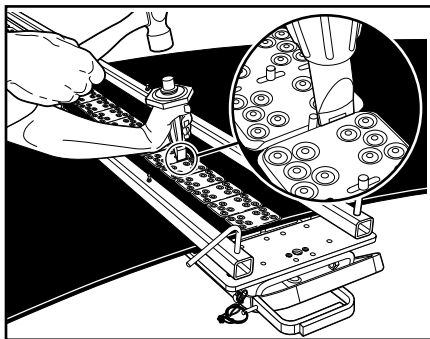

17. For easier troughing on belts up to 35° trough, remove bridges between plates in troughing area using the BR151 Bridge Removal Tool.

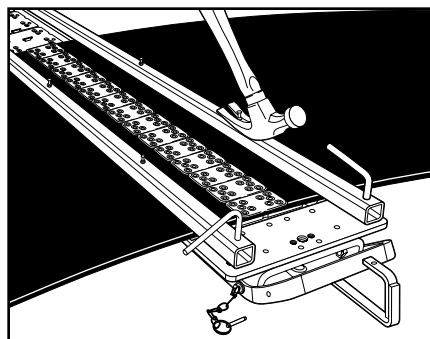

18. Unlock and remove cam rods (C). Remove nails and clamp bars (B).

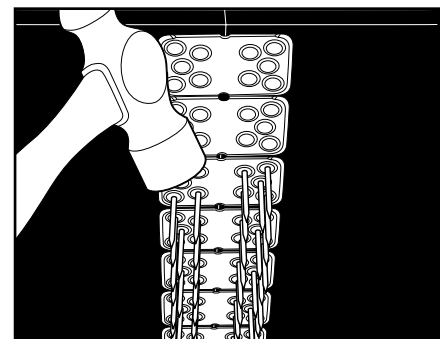

19. Remove MBRTA. Remove pilot nails and clips with a hammer. If fasteners are 1" (25mm) or more from edge of belt, notch belt. Remove nails from MBRTA.



2525 Wisconsin Avenue • Downers Grove, IL 60515-4200 U.S.A.
Tel: (630)-971-0150 • Fax: (630)-971-1180 • E-mail: info@flexco.com

Visit www.flexco.com for other Flexco locations and products.

©2014 Flexible Steel Lacing Company. Flexco® is a registered trademark. 04-14. For Reorder: X2311

