

TWIN POLE V-PLOUGH Belt Ploughs

Maximum Protection for Pulleys

Keeping your conveyor beltlines clean is a problem that is not confined to the head pulley area. Many times rocks, spillage, and other debris get into the take-up and tail pulleys causing damage to the belt, lagging, and mechanical splices. This can lead to belt tracking problems and other maintenance and repair expenses. The V-Plough is uniquely designed to clean the inside of the return belt and eliminate nagging problems.

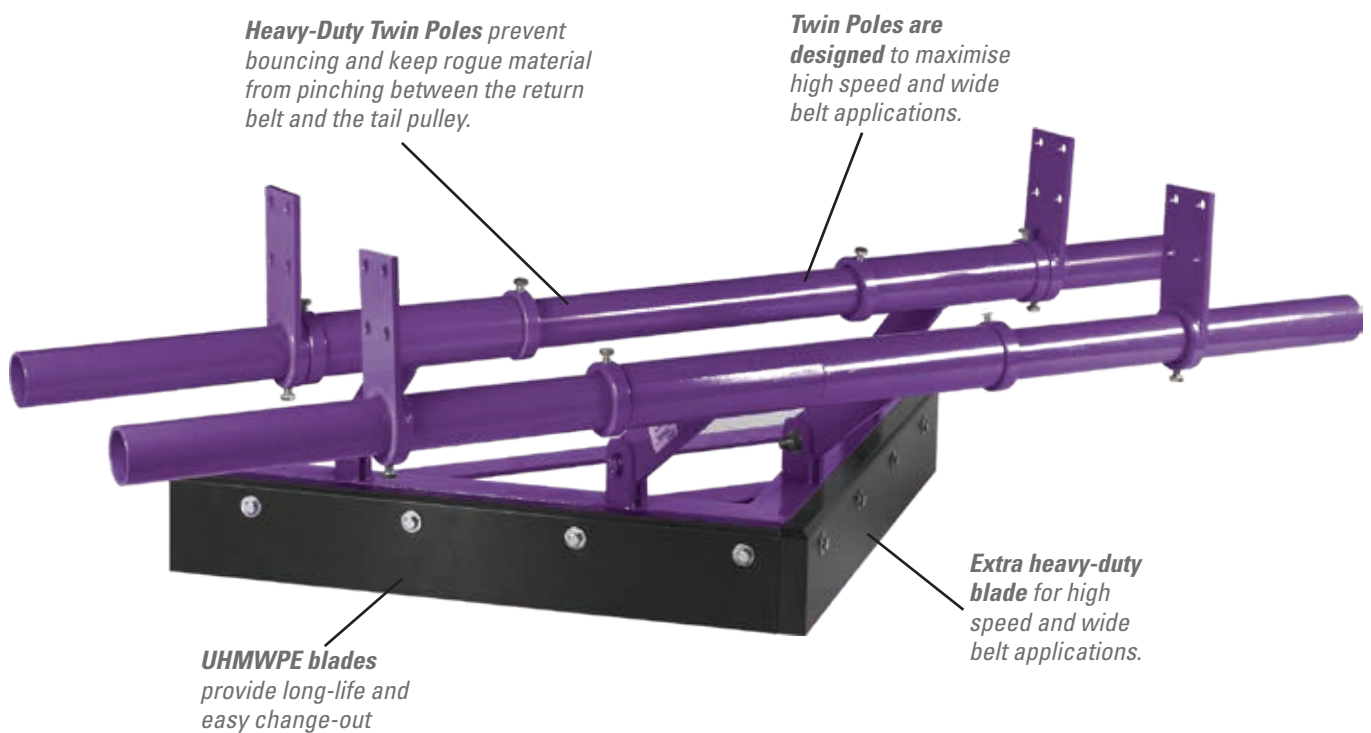

Features and Benefits

- Cleans the inside/clean side of the return belt
- Eliminates conveyor damage and belt mistracking caused by debris lodging in the tail pulley or take-up
- Floating design self-adjusts as blade wears, eliminating the need for manual adjustment
- Available in a range of sizes for multiple belt widths
- Removes carryback on both sides of the conveyor

TWIN POLE V-PLOUGH

Belt Ploughs

Specifications and Guidelines

- Belt Speed: 6 m/s
- 150 mm high x 40 mm thick UHMWPE blade"
- Suits belts from 900 mm to 3000 mm
- Provides total belt coverage
- Fully assembled for quick installation
- All steel components are grit blasted and powder coated—fasteners are 316 Stainless Steel
- Available in Stainless Steel

Ordering Information

Twin Pole V-Plough				
Belt Width (mm)	Ordering Number	Item Code	Ordering Number	Item Code
	Powder Coated		Stainless Steel	
900	HBP-TP-900	A2283	HBP-TP-900 S/S	A2474
1050	HBP-TP-1050	A2284	HBP-TP-1050 S/S	A2475
1200	HBP-TP-1200	A2285	HBP-TP-1200 S/S	A2476
1400	HBP-TP-1400	A2286	HBP-TP-1400 S/S	A2477
1500	HBP-TP-1500	A2287	HBP-TP-1500 S/S	A2478
1600	HBP-TP-1600	A2288	HBP-TP-1600 S/S	A2479
1800	HBP-TP-1800	A2289	HBP-TP-1800 S/S	A2480
2000	HBP-TP-2000	A2290	HBP-TP-2000 S/S	A2481
2200	HBP-TP-2200	A2291	HBP-TP-2200 S/S	A2482
2400	HBP-TP-2400	A2292	HBP-TP-2400 S/S	A2483
2500	HBP-TP-2500	A2293	HBP-TP-2500 S/S	A2484

Contact Flexco for additional sizes.

V-Plough Replacement Blades		
Belt Width (mm)	Ordering Number	Item Code
	Polyurethane blades (Pair)	
750	HBP750-B-TP	A2460
900	HBP900-B-TP	A2316
1050	HBP1050-B-TP	A2317
1200	HBP1200-B-TP	A2318
1500	HBP1500-B-TP	A2320
1600	HBP1600-B-TP	A2321
1800	HBP1800-B-TP	A2322
2000	HBP2000-B-TP	A2323
2200	HBP2200-B-TP	A2325
2400	HBP2400-B-TP	A2324
2500	HBP2500-B-TP	A2326

Note: Polyurethane blades are approved for use in underground mines.

Easy Installation and Maintenance

The V-Plough comes fully assembled and can be placed right into position on the conveyor. Simple, step-by-step instructions are included for quick installation. Since the blade is self-adjusting, no blade readjustment is needed throughout the blade life to accommodate for wear. Blade change-out is simple. Replacement blades are cut to size and new hardware is included.



Flexco (Aust.) Pty. Ltd • 10 Solent Circuit, Norwest • NSW, Australia, 2153 • Australia
Tel: 612-8818-2000 • Fax: 612-8824-6333 • E-mail: salesau@flexco.com

Visit www.flexco.com for other Flexco locations and products.

©2019 Flexible Steel Lacing Company. 08/27/19. For reorder: X2267

