

# Electric Belt Cutter

## Blade Replacement Instructions

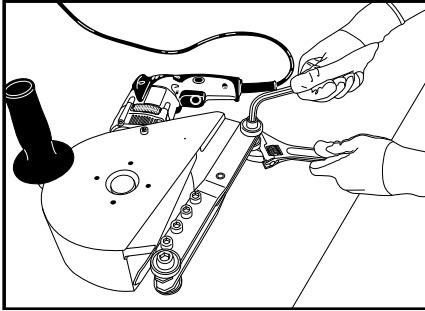

1. Unplug drill from power source.  
Loosen Rear Carriage Bolt.

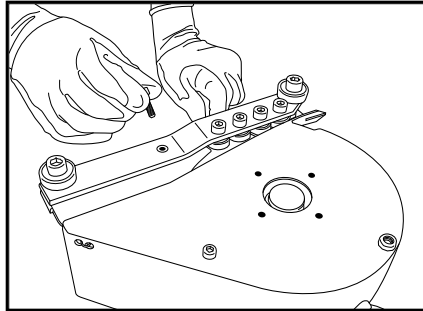

2. Remove Carriage Support Bolt and Nut.  
**WARNING: DO NOT TOUCH BLADE.**



3. Rotate Carriage away from Blade.

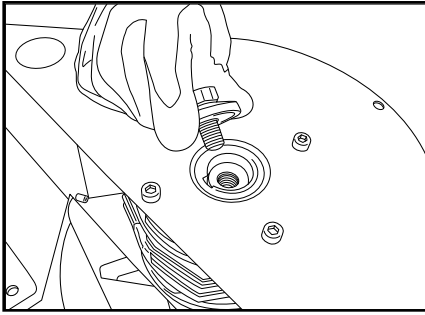

4. Remove Blade Mount Bolt.

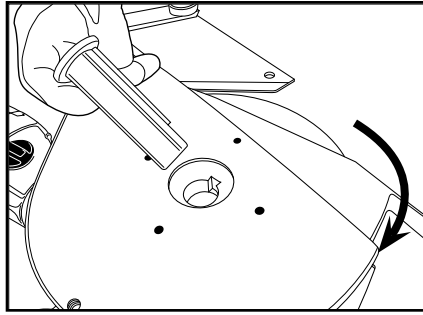

5. Remove Blade Mount Shaft.  
**WARNING: Blade edge is very sharp.  
DO NOT TOUCH EDGE OF BLADE!**  
Push the Blade Guard into the Cutter Housing just enough to clear the Blade. Remove the Blade and Blade Spacer carefully.

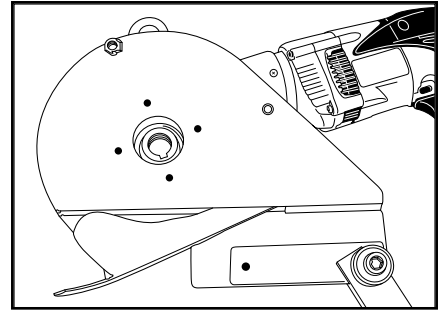

6. Carefully replace Blade Spacer and slide new Blade into Housing. Align keyway in Blade, Spacer, and Gearbox and insert Blade Mount Shaft. Secure Blade with Blade Mount Bolt.

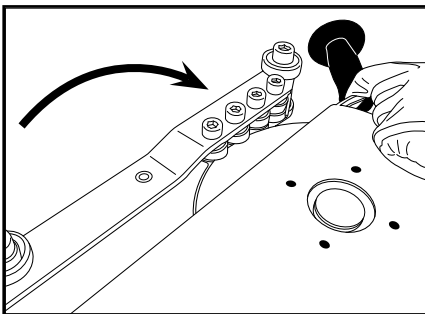

7. Carefully pivot Carriage back into place. Be careful not to damage Blade as it slides between the Belt Support Bearings.

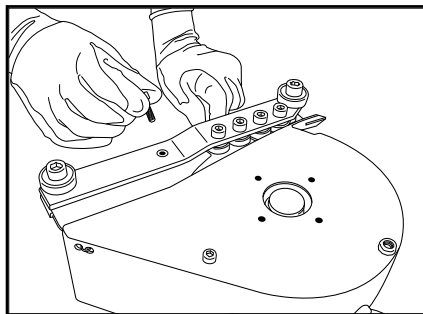

8. Replace Carriage Support Bolt. Tighten rear Carriage Bolt.

### ⚠ CAUTION

Do not attempt to sharpen blades. This will affect cutting completely through belt.

### ⚠ WARNING

Always wear cut-proof safety gloves and safety glasses when replacing blade. Blade is razor sharp, treat it accordingly.

### ⚠ WARNING

Before performing a blade replacement, remove the plug from the socket and follow all procedures noted in instructions.

### ⚠ WARNING

Only authorized and trained technicians should work on the cutter.

### ⚠ WARNING

Test the cutter after blade replacement to make sure that it can be used safely.



2525 Wisconsin Avenue • Downers Grove, IL 60515-4200 U.S.A.  
Telephone: 1-630-971-0150 • Fax: 1-630-971-1180 • E-mail: info@flexco.com

Visit [www.flexco.com](http://www.flexco.com) for other Flexco locations and products.

©2008 Flexible Steel Lacing Company. 12-13. For Reorder: X2144

