

SmartClamp™ *

Conveyor Belt Clamps

Safety Instructions

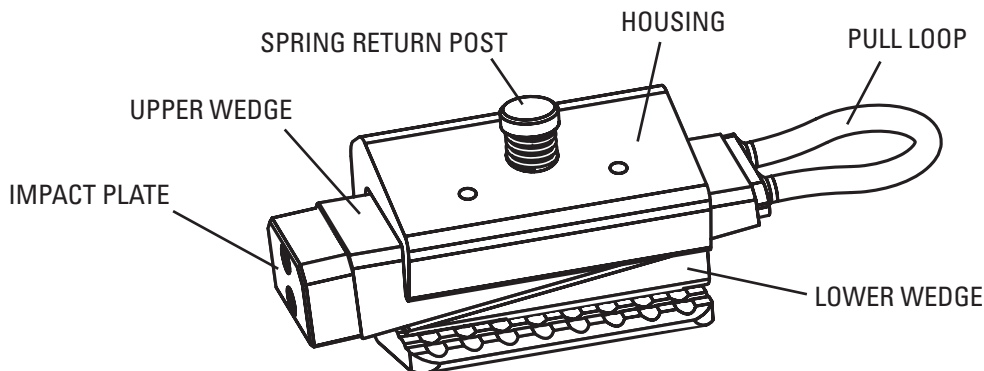

*Patent 7,552,517

! BEFORE OPERATING THE SMARTCLAMPS™, USERS MUST READ AND UNDERSTAND THE FOLLOWING INFORMATION:

SPECIFICATIONS:

Maximum Clamp Capacity: 450 kg (1000 lbs)
Maximum Belt Thickness: 8 mm (5/16")
Maximum Pull Angle: 15°

SMARTCLAMP SET INCLUDES:

4 Clamps (2 "A" clamps, 2 "B" clamps)
2 Carrying Bags

SAFETY:



DANGER

OSHA Lock-out/Tag-out (LOTO) regulations, Ref. 29 CFR 1910.147, must be followed before belt clamps are installed. Failure to use LOTO exposes workers to unexpected conveyor start-up and release of internal potential energy. Severe injury or death can result.

- **Before clamping, lock-out/tag-out the conveyor system**
- **Disengage take-up prior to use**

Highlights of OSHA Lock-out/Tag-out Procedures Apply LOTO

- Notify affected employees
- Shut down equipment - normal shutdown
- Isolate all energy to the equipment
- Lock and tag energy controls
- Release stored and/or residual energy
- Test controls to ensure inadvertent startup is not possible

Restore from LOTO

- Notify affected employees - Locks and Tags to be removed
- Check equipment to ensure all guards are in place and tools removed
- Ensure controls are in Neutral or Off position
- Properly remove Locks and Tags and make equipment ready for use



WARNING

Spring-back hazard: the clamp tensioning device (come-along) may impact workers and inflict serious injury if a sudden tension release occurs. To avoid the spring-back hazard:

- Use chain type come-along devices with uncompromised integrity
- Do not use damaged clamps; Upper Wedge must slide smoothly
- Insert belt edge completely into clamp
- Always seat clamp using two hammer strikes on impact plate
- Do not place clamp over defective belt edge
- Keep pulling force below 450 kg (1000 lbs). Rated come-along capacity must not exceed 450 kg (1000 lbs). Stop pulling if slipping is observed
- Never stand in-line with pulling force
- Always wear approved eye protection (ANSI Z87.1)



CAUTION

- Use non-marring hammer/mallet for striking impact plate and pull loop. This will extend the working life of these components.
- Do not modify the clamps in any form. The strength and function of modified clamps are unknown and may be compromised.
- The clamp housing is high strength aluminum. To prevent damage do not drop or store with other metal appliances.
- Restrict clamp to belt thicknesses below 8mm (5/16"); otherwise the clamping mechanism will not function properly.
- If service is required, return clamp to manufacturer. The clamp is fabricated with high performance materials that require special repair techniques.
- Follow the come-along safety instructions.
- Wear safety shoes and hard hats. Consult ANSI Z87.1 for approved safety eyewear.
- Maintain clamps in a clean state. Exercise caution if using compressed air to clean.

INSTRUCTIONS:

1. Apply LOTO procedures; Lock out conveyor power and disengage take-up.
2. Follow safety mandates in this manual.
3. Fully open clamp; push the pull loop toward the housing.
4. Lift edge of belt; slide opened clamp over belt edge with pull loops facing the splice area until belt is fully engaged in the housing.
5. With a soft hammer, initially engage clamp by striking the impact plate; 2 blows. Repeat this process until all four clamps are in the proper position (See Fig. 1).

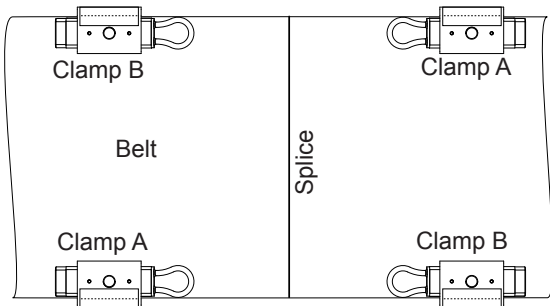

Fig. 1

6. Tension clamp in longitudinal direction of the belt. This can be achieved by one of two methods:
 - a. **Clamp-To-Clamp (preferred method):** Attach come-alongs to pull loop of clamps across the splice (See Fig. 2).

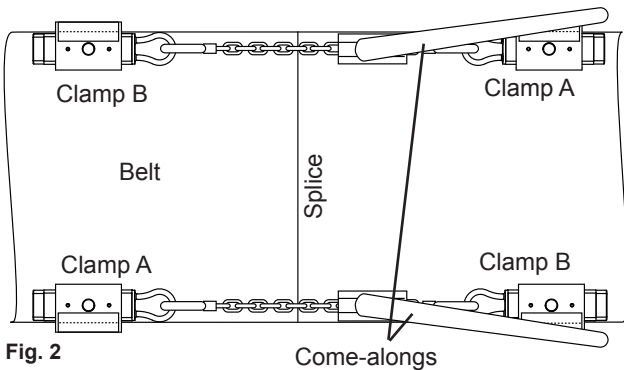

Fig. 2

- b. **Clamp-To-Structure:** On one side of the splice, attach chains to pull loop of clamp and to conveyor structure (Fig. 3). On other side of splice, attach come-alongs to pull loop of clamp and to conveyor structure. It is important to secure to structure at least 2.5 meters back, so as to keep the angle of pull less than 15°.

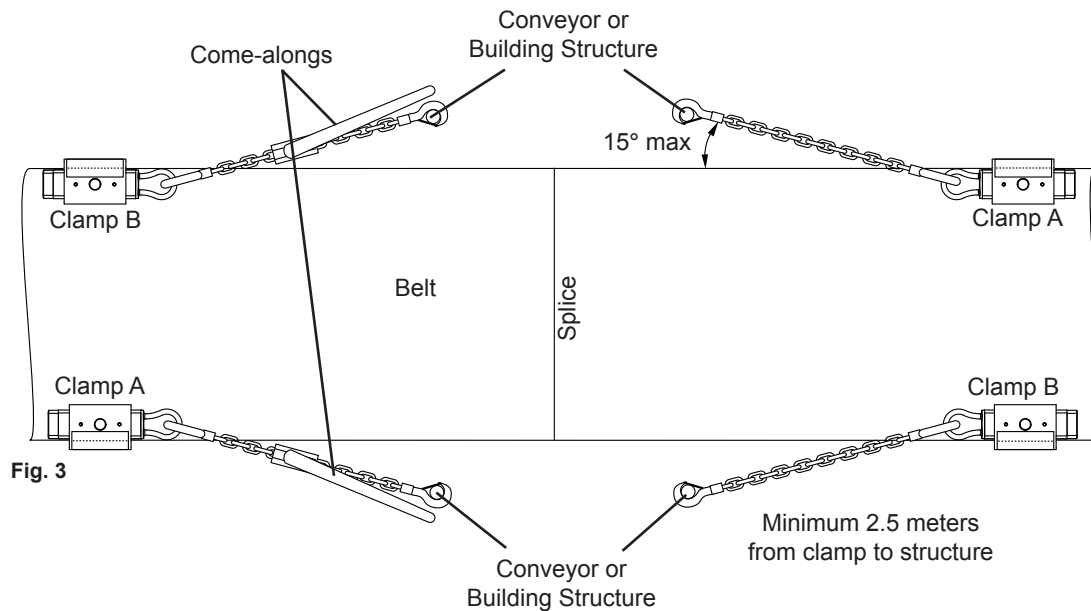

Fig. 3

7. Tension come-alongs until the desired amount of belt slack is obtained. Come-alongs should be tensioned at the same time to avoid overloading one side of the belt. If this cannot be done simultaneously by two individuals, one person should alternate between the two units to keep the tension on both edges at approximately the same level.
8. Conduct belt maintenance at this time.
9. After belt maintenance is complete, loosen and remove come-alongs. This should be done simultaneously by two individuals to prevent overloading one belt edge.
10. With a soft hammer, strike pull loop until wedges disengage.
11. Remove clamps from belt edges.
12. Return conveyor to service - continue LOTO procedure for "completion" scenario.

STORAGE:

Two carrying bags are included with the sale. Each bag will carry two clamps. Place clamps in outer compartments. Inner compartment can be used to carry additional supplies such as soft-faced hammer, measuring tape, etc. Pull and secure drawstring after clamps and supplies are in the bag.

Flexco (Aust.) Pty. Ltd • 10 Solent Circuit • Baulkham Hills NSW 2153 • Australia
Tel: 612-8818-2000 • Fax: 612-8824-6333 • E-mail: salesau@flexco.com

Visit www.flexco.com for other Flexco locations and products.

©2018 Flexible Steel Lacing Company. 02/28/18. For reorder: X1798

