

EZP1

Standard-Duty Primary Cleaner

Simple, Quick, Effective

The EZP1 Primary Cleaner is not your average solid-blade belt cleaner that mounts on the head pulley. It features a unique uni-blade design that combines simple, do-it-yourself installation, quick maintenance, and effective cleaning results with a price tag that you can afford.

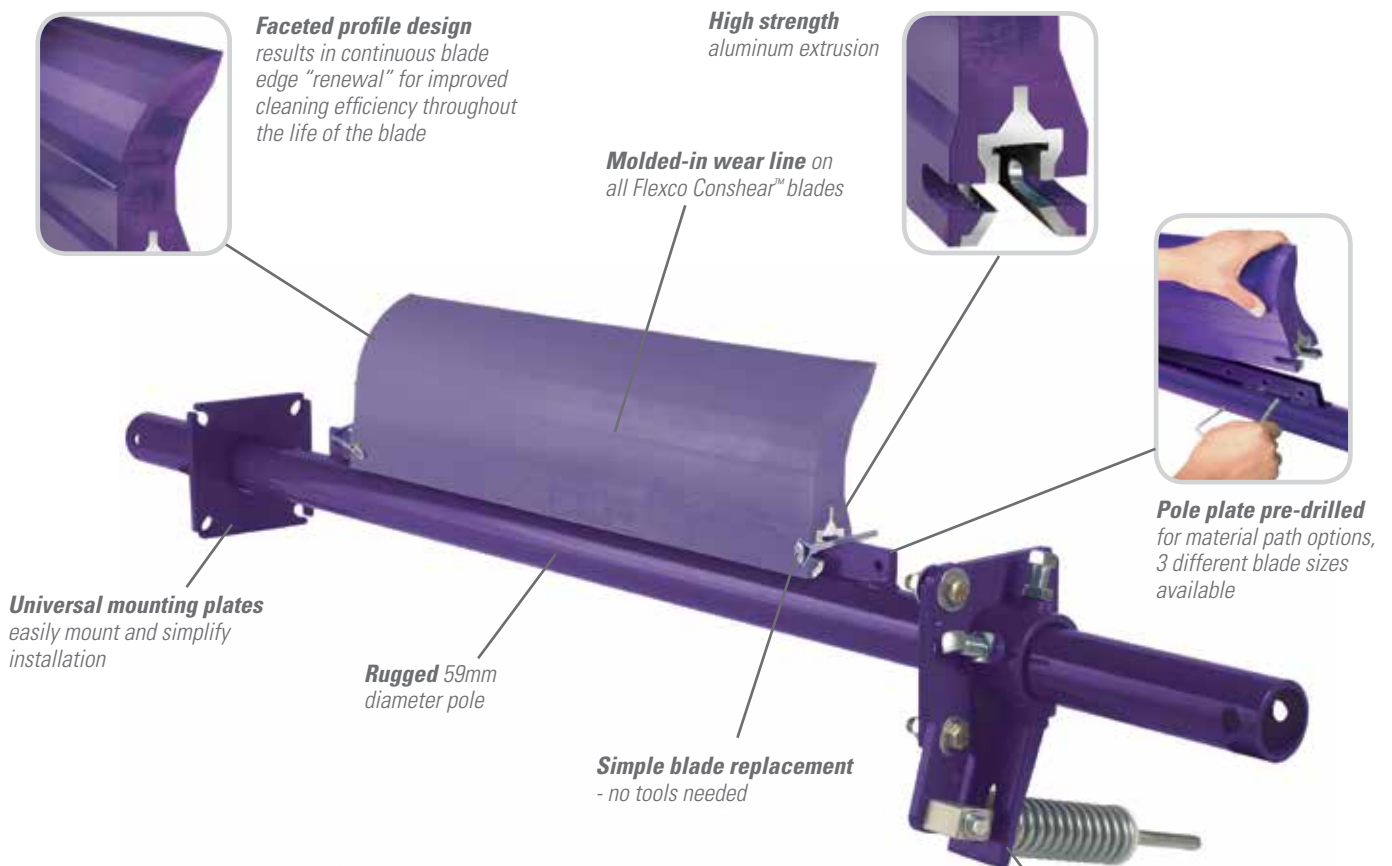

Features and Benefits

- **Works with Flexco mechanical splices.** The spring tensioner allows the blade to quickly move away from the belt when a splice passes. The polyurethane blade material easily glides over the splice without damage and with minimal cleaning disruption.
- **Compact, streamlined design.** The EZP1 Primary Cleaner requires only 100 mm of horizontal clearance for correct installation. Its streamlined contours prevent material buildup on the blade or the pole.
- **Can be used on reversing belts.** Installing cleaners on both pulleys gives superior cleaning results on belts that run in both directions.
- **Fits most conveyor structures.** Available for belt widths from 300-1800 mm.
- **Blade can be used on other cleaners.** The Conshear™ blade can be used as a replacement blade on many OEM cleaners.

EZP1

Standard-Duty Primary Cleaner

Specifications and Guidelines

- **Maximum Belt Speed**
3.5 M/sec
- **Temperature Rating**
-35°C to 82°C
- **Minimum Pulley Diameter**
250 mm
- **Blade Height**
185 mm
- **Usable Blade Wear Length**
100 mm
- **Blade Material**
Urethane 83 durometer (proprietary blend for abrasion resistance and long wear)
- **Available for Belt Widths**
300 to 1800 mm
- **Horizontal Clearance Required**
100 mm
- **Vertical Clearance Required**
238 mm
- **Pole Length**
Cleaner size up to 1200mm + 750mm
Cleaner size over 1200mm + 850mm
- **Maximum Conveyor Span**
Cleaner size up to 1200mm + 625mm
Cleaner size over 1200mm + 725mm

Pole Location Specs

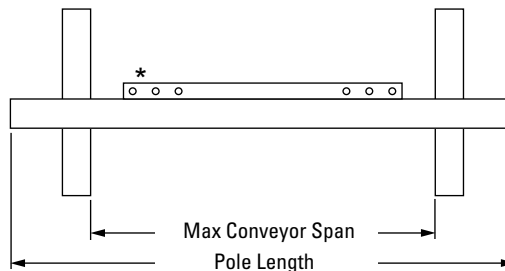
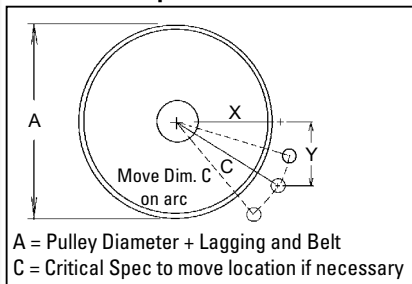

Pole Location Chart

A	X	Y	C	A	X	Y	C	A	X	Y	C
250	74	230	242	500	235	230	329	725	374	230	439
275	92	230	248	525	249	230	339	775	389	230	452
300	108	230	254	550	266	230	352	775	403	230	464
325	131	230	265	575	283	230	365	825	417	230	477
350	146	230	273	600	299	230	377	825	432	230	489
375	166	230	284	625	314	230	390	850	446	230	501
400	179	230	291	650	330	230	402	875	460	230	514
425	195	230	301	675	346	230	415	900	474	230	526
450	207	230	309	700	360	230	427				

Ordering Information

EZP1 Primary Cleaners - Belt Width Minus 50mm Blade

Belt Width		Blade Coverage		Ordering Number	Item Code
in.	mm	in.	mm		
12	300	10	250	EZP1-300-50	81090
18	450	16	400	EZP1-450-50	81091
24	600	22	550	EZP1-600-50	81092
30	750	28	700	EZP1-750-50	81093
36	900	34	850	EZP1-900-50	81094
42	1050	40	1000	EZP1-1050-50	81095
48	1200	46	1150	EZP1-1200-50	81096
54	1350	52	1300	EZP1-1350-50	81097
60	1500	58	1450	EZP1-1500-50	81098
72	1800	70	1750	EZP1-1800-50	81099

EZP1 Primary Cleaners - Belt Width Minus 200mm Blade

Belt Width		Blade Coverage		Ordering Number	Item Code
in.	mm	in.	mm		
12	300	-	-	EZP1-450-200	81100
18	450	10	250	EZP1-600-200	81101
24	600	16	400	EZP1-750-200	81102
30	750	22	550	EZP1-900-200	81103
36	900	28	700	EZP1-1050-200	81104
42	1050	34	850	EZP1-1200-200	81105
48	1200	40	1000	EZP1-1350-200	81106
54	1350	46	1150	EZP1-1500-200	81107
60	1500	52	1300	EZP1-1800-200	81108
72	1800	64	1600	EZP1-1800-200	81108

ConShear™ Replacement Blades

Blade Width		Ordering Number	Item Code
in.	mm		
10	250	CRB 250	76582
16	400	CRB 400	76583
22	550	CRB 550	76584
28	700	CRB 700	76585
34	850	CRB 850	76586
40	1000	CRB 1000	76587
46	1150	CRB 1150	76588
52	1300	CRB 1300	76589
58	1450	CRB 1450	76590
64	1600	CRB 1600	76591
70	1750	CRB 1750	76592

Flexco (Aust.) Pty. Ltd • 10 Solent Circuit • Baulkham Hills NSW 2153 • Australia
Tel: 612-8818-2000 • Fax: 612-8824-6333 • E-mail: sales@flexco.com.au • Web: www.flexco.com

Australia: 61-2-8818-2000 • Chile: 56-2-8967870 • China: 86-21-33528388
England: 44-1274-600-942 • Germany: 49-7428-9406-0 • India: 91-44-4354-2091
Mexico: 52-55-5674-5326 • Singapore: 65-6281-7278 • South Africa: 27-11-608-4180 • USA: 1-630-971-0150

Authorized Distributor:

