

Installing Clipper® Fasteners with the Roller Lacer® and Microlacer®

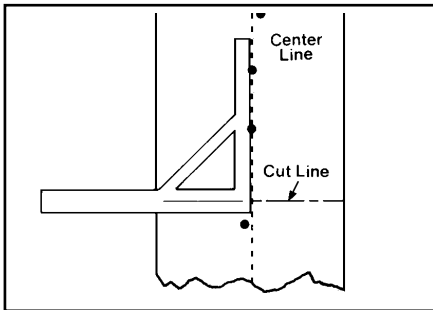

For Roller Lacer Serial Nos. 60000+; Microlacer Serial Nos. 40000+

Belt Preparation:



1. Square belt end off centerline.

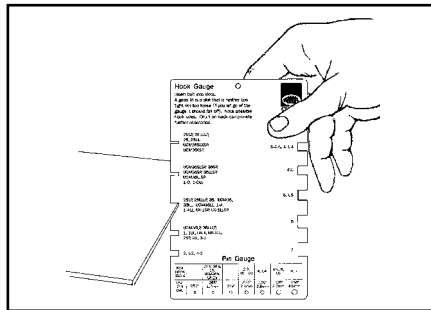

2. Select the proper size hook for your application.

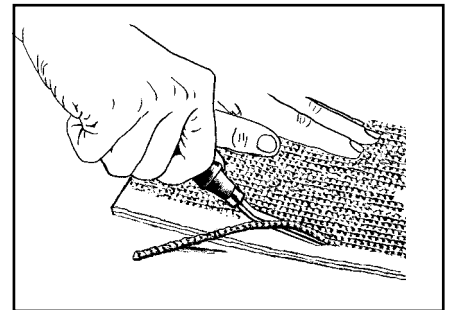

3. If belt has an impression cover, skive back 1" (25mm) from the belt end.

Prepare Lacer for Use: Face Strip Installation

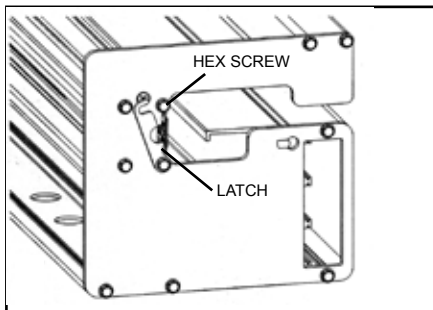

1. Loosen hex screw to allow Face Strip Retaining Latch to rotate out of the way. Insert Face Strip, reposition Latch and tighten screw.

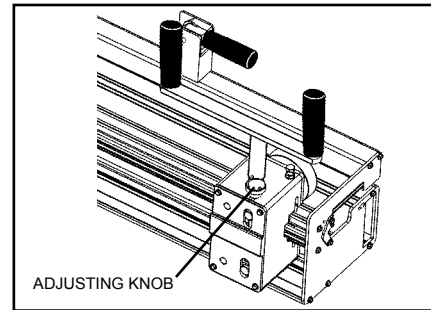

2. Position lacer head to the end of the tool. Turn knob clockwise to open rollers.

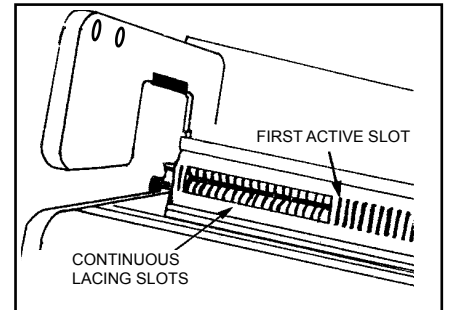

3. Insert hooks into the first active slot of the face strip. Secure with lacer pin.

Lacer Operation:

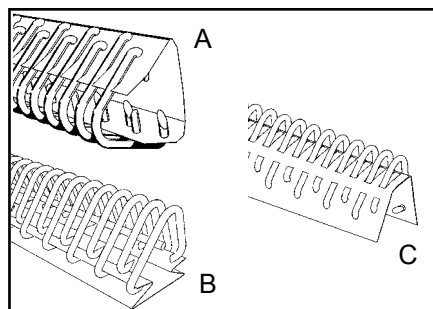

4. If using hooks as shown in A or B, remove carding paper at this time. If using hooks as shown in C, remove carding paper after installing hooks.

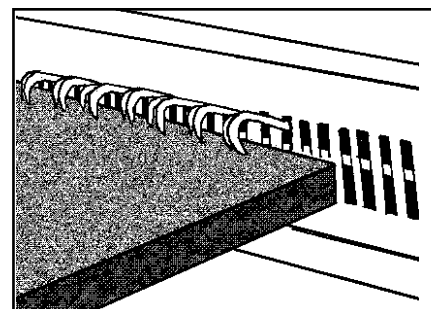

1. Guide belt through clamp; insert belt end into hook points and flush against the entire width of the face strip.

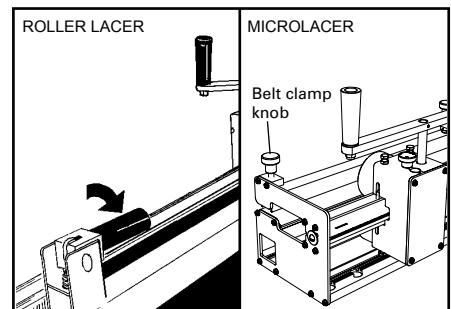

2. Lock belt clamp.

Lacer Operation (cont.):

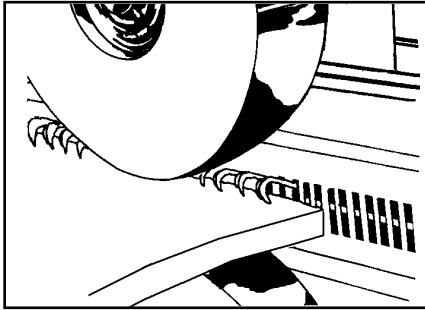

3. Position rollers over hooks.
4. Turn adjusting knob counter-clockwise until rollers touch hooks.

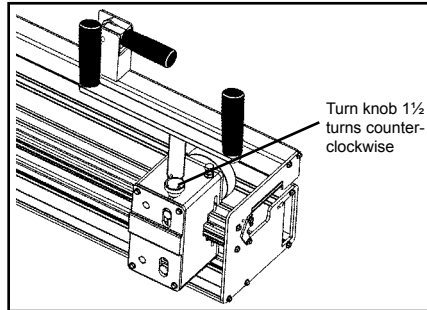

5. Return lacer head to end of lacer and turn adjusting knob 1/2 additional turns counter-clockwise.

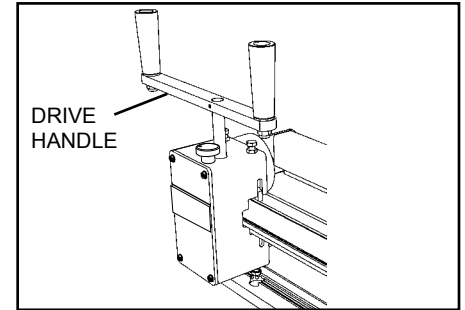

6. Using the handle, move the lacer head across the belt width at a smooth speed.

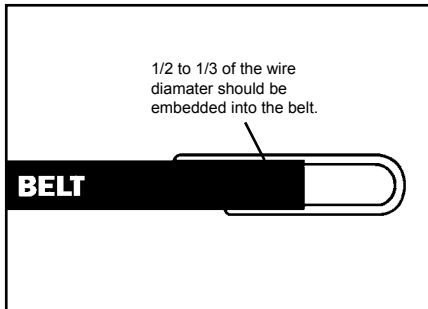

7. Turn adjusting knob counter-clockwise 1/2 turn and return head across the belt. Repeat until hooks are embedded 1/3 to 1/2 into the belt.

8. Remove lacer pin. Release belt clamp. Remove belt from lacer.
NOTE: The belt will need to be 'continuous laced' if it is wider than the lacer.

Continuous Lacing:

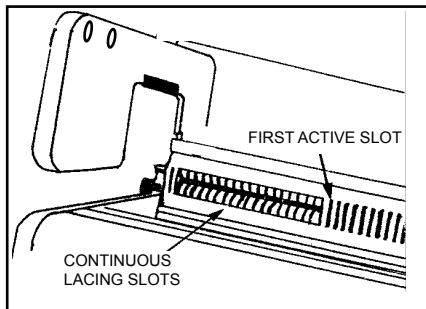

1. Starting on one side of the belt, lace the first section using the 'Lacer Operation' instructions listed above.
2. Open rollers.
3. Insert hooks into face strip, starting with the first active slot.
4. Insert lacer pin. Remove carding paper from hooks, if applicable.
5. Guiding belt through the belt clamp, position laced hooks into the continuous lacing slots, directly next to the first active slot. Keep belt flush against the face strip. Clamp belt.
6. Lace this section using Steps 3-8 of the 'Lacer Operation' instructions.

Helpful Tip: When continuous lacing it is recommended to lace the shorter length of belt first and then continue with the longer section of belt. Example: when using a 24" Roller Lacer to lace a 36" wide belt, lace the 12" section of belt first and then follow the process to continuous lace the remaining 24" of belt.

Maintenance:

- Wipe debris off chain-body extrusion periodically with a dry cloth to prolong the UHMW guide life.
- If head begins to rock back and forth, visit www.flexco.com for instructions on adjustment techniques.



2525 Wisconsin Avenue • Downers Grove, IL 60515-4200 • USA
Tel: (630) 971-0150 • Fax: (630) 971-1180 • E-mail: info@flexco.com

Visit www.flexco.com for other Flexco locations and products.

©2008 Flexible Steel Lacing Company. Clipper®, Roller Lacer® and Microlacer® are registered trademarks.
10-23-17. For Reorder: X1452

